

KAMESH MECHROCKS

Reasoning & Aptitude

For

Various Competitive Examinations

- DRDO
- ISRO
- NTPC
- HAL
- SAIL, etc....

- UPSC
- SSC
- Railways
- MBA Entrance
- Bank (PO), etc....

- Infosys
- Wipro
- TCS
- HCL
- etc....

by

Nem Singh (IRS)



MADE EASY Publications

A unit of MADE EASY Group

Corporate Office: 44-A/1, Kalu Sarai, New Delhi-16

Regd. Office: 25-A, Ber Sarai, New Delhi-16

Website: www.madeeasypublications.org

Phone: 011-45124612, 011-32059862

W



MADE EASY Publications

Corporate Office: 44-A/1, Kalu Sarai, New Delhi-16; Regd. Office: 25-A, Ber Sarai, New Delhi-110016
Website: www.madeeasypublications.org; Phone: 011-26560862, 011-32059862
E-mail: info@madeeasypublications.org; iesmadeeasy@yahoo.co.in

Reasoning & Aptitude

Copyright © 2010, by MADE EASY Publications.

All rights are reserved. No part of this publication may be reproduced, stored in or introduced into a retrieval system, or transmitted in any form or by any means (electronic, mechanical, photocopying, recording or otherwise), without the prior written permission of the above mentioned publisher of this book.

1st Edition: 2008

2nd Edition: 2009

3rd Edition : 2010

CONTENTS

Section A: Arithmetic

1. Number System	9-26
2. Average	27-40
3. Ratio & Proportion.....	41-54
4. Percentage	55-76
5. Profit and Loss.....	77-94
6. Simple Interest & Compound Interest	95-111
7. Time & Work.....	113-135
8. Time, Speed & Distance	137-161

Section B: Algebra & Geometry

1. Surds, Indices & Logarithm	165-175
2. Progression.....	177-192
3. Permutation & Combination	193-208
4. Probability.....	209-226
5. Geometry.....	227-270

Section C: Reasoning & Data Interpretation

1. Blood Relation	273-275
2. Coding & Decoding	277-281
3. Cubes and Dices	283-290
4. Direction Sense Test	291-300
5. Graph.....	301-306
6. Table	307-311
7. Bar Diagram	313-325
8. Pie-chart	327-338
9. Miscellaneous Puzzles.....	339-350
10. Logical Venn Diagram	351-357
11. Analytical Reasoning	359-364





Number System

The chapter of number system is amongst most important chapter in the whole of mathematics syllabus for the competitive Examination.

We can consider this chapter as the backbone of mathematics. The students are advised to go through this chapter with utmost care, understanding each and every aspect of this topic.

In this chapter basic definition of different types of numbers are given. Then on the basis of this, various questions with solved examples are given for easy understanding.

Number System

Natural Numbers

Counting numbers 1, 2, 3, 4, 5 are known as natural numbers.

The set of natural numbers can be represented by $N = \{1, 2, 3, 4, 5 \dots\}$

Whole Numbers

If we include 0 among the natural numbers, then the numbers 0, 1, 2, 3, 4, 5 etc are called whole numbers.

Whole number $W = \{0, 1, 2, 3, 4, 5 \dots\}$

Clearly, every natural number is a whole number but 0 is a whole number which is not a natural number.

Integers

All counting numbers and their negatives including zero are known as integers.

The set of integers

$$I = \{\dots, -3, -2, -1, 0, 1, 2, 3, 4, \dots\}$$

Positive Integers

The set $\{1, 2, 3, 4, 5, \dots\}$ is a set of all positive integers.

Positive Integers and natural numbers are synonyms.

Negative Integers

The set $\{-1, -2, -3, \dots\}$ is a set of all negative integers. 0 is neither positive nor negative.

Rational Numbers

The numbers of the form p/q , where p and q are integers and $q \neq 0$ are known as rational numbers.

$$\text{eg.: } \frac{2}{3}, \frac{5}{7}, \frac{-4}{9} \text{ etc.}$$

Irrational Numbers

Those numbers which when expressed in decimal form are neither terminating nor repeating decimals, are known as irrational numbers

$$\text{eg.: } \sqrt{2}, \sqrt{3}, \sqrt{5}, \pi \text{ etc.}$$

Note that the exact value of π is not $\frac{22}{7}$. $\frac{22}{7}$ is a rational number while π is an irrational number. Some times π is also considered equivalent to $\frac{355}{113}$. This value is also approximate value of π and not the exact value.

Similarly 3.14 is not an exact value of it.

Real Numbers

The rational and irrational numbers combined together are called real numbers.

eg.: $\frac{12}{19}, \sqrt{5}, 4 + \sqrt{2}, 6 + \sqrt{5}$ etc are all real numbers.

The set of all real numbers are denoted by R.

Complex Numbers

Complex numbers can be represented in form of $a + ib$, where a and b are real numbers and $i = \sqrt{-1}$. Thus $3+4i, 6+2i, i, 2i$ etc are Complex numbers:

Even Numbers

All those numbers which are exactly divisible by 2 are called even numbers.

eg.: 2, 4, 6, 8, 10, etc.

Odd Numbers

All those numbers which are not exactly divisible by 2 are called odd number.

Eg.: 1, 3, 5, 7, 9 etc.

Prime Numbers

Number divisible by 1 and itself and not divisible by any other number are called prime number.

Eg.: 2, 3, 5, 7, 11 etc.

Note: 2 is the only Prime number which is even. Rest all are odd Prime numbers.

Composite Numbers

Natural numbers greater than 1 which are not prime are composite numbers.

eg.: 4, 6, 9, 15, etc.

Co prime Numbers

Two numbers which have only 1 as the common factors are called Coprimes or relatively prime to each others

eg.: (3, 7) (8, 9) (36, 25) etc.

Test of Divisibility

1. Divisibility by 2

A number is divisible by 2 if the unit digit is zero or divisible by 2.

eg.: 22, 42, 84, 3872 etc.

2. Divisibility by 3

A number is divisible by 3 if the sum of digit in the number is divisible by 3.

eg.: 2553

Here $2 + 5 + 5 + 3 = 15$, which is divisible by 3 hence 2553 is divisible by 3.

3. Divisibility by 4

A number is divisible by 4 if its last two digit is-divisible by 4.

eg.: 2652, here 52 is divisible by 4 so 2652 is divisible by 4

eg.: 3772, 584, 904 etc

4. Divisibility by 5

A number is divisible by 5 if the units digit in number is 0 or 5.

eg.: 50, 505, 405 etc.

5. Divisibility by 6

A number is divisible by 6 if the number is even and sum of digits is divisible by 3.

eg.: 4536 is an even number also sum of digit $4 + 5 + 3 + 6 = 18$ is divisible by 3.

eg: 72, 8448, 3972 etc.

6. Divisibility by 8

A number is divisible by 8 if last three digit of it is divisible by 8.

eg.: 47472 here 472 is divisible by 8 hence this number 47472 is divisible by 8.

7. Divisibility by 9

A number is divisible by 9 if the sum of its digit is divisible by 9.

eg.: 108936 here $1+0+8+9+3+6$ is 27 which is divisible by 9 & hence 108936 is divisible by 9.

8. Divisibility by 10

A number is divisible by 10 if its unit digit is 0.

eg.: 90, 900, 740, 34920 etc.

9. Divisibility by 11

A number is divisible by 11 if the difference of sum of digit at odd places and sum of digit at even places is either 0 or divisible by 11.

eg.: 1331, the sum of digit at odd place is $1+3$ and sum of digit at even places is $3+1$ and their difference is $4 - 4 = 0$. so 1331 is divisible by 11.

HCF and LCM of Numbers**H.C.F.**

(Highest Common Factor) of two or more number is the greatest number that divides each one of them exactly.

For example 8 is the highest common factor of 16 and 40.

HCF is also called greatest common divisor (G.C.D.) or G.C.M. i.e. Greatest Common measure.

L.C.M.

(Least Common Multiple) of two or more number is the least or a lowest number which is exactly divisible by each of them.

For example LCM of 8 and 12 is 24, because it is the first number which is multiple of both 8 and 12.

LCM and HCF of Fractions

Fractions are written in form of $\frac{\text{Numerator}}{\text{Denominator}}$.

Where denominator is not equal to zero.

$$\text{H.C.F of Fraction} = \frac{(\text{H.C.F. of Numerators})}{(\text{LCM of Denominators})}$$

$$\text{L.C.M of Fraction} = \frac{(\text{LCM of Numerators})}{(\text{HCF of Denominators})}$$

Example: find HCF & LCM of $\frac{1}{2}$, $\frac{2}{3}$ and $\frac{3}{7}$

$$\text{HCF} = \frac{\text{H.C.F. of (1,2,3)}}{\text{L. C. M. (2, 3, 7)}} = \frac{1}{42}$$

$$\text{LCM} = \frac{\text{LCM of (1,2,3)}}{\text{HCF of (2, 3, 7)}} = \frac{6}{1} = 6$$

Important Algebraic Formulae

$$1. (a+b)^2 = a^2 + 2ab + b^2$$

$$2. (a-b)^2 = a^2 - 2ab + b^2$$

$$3. (a-b)(a+b) = a^2 - b^2$$

$$4. (a+b)^2 + (a-b)^2 = 2(a^2 + b^2)$$

$$5. (a+b)^2 - (a-b)^2 = 4ab$$

$$6. (a+b)^3 = a^3 + 3a^2b + 3ab^2 + b^3 \\ = a^3 + b^3 + 3ab(a+b)$$

$$7. (a-b)^3 = a^3 - 3a^2b + 3ab^2 - b^3 \\ = a^3 - b^3 - 3ab(a-b)$$

$$8. a^3 + b^3 = (a+b)(a^2 - ab + b^2)$$

$$9. a^3 - b^3 = (a-b)(a^2 + ab + b^2)$$

$$10. \frac{a^3 + b^3 + c^3 - 3abc}{a^2 + b^2 + c^2 - ab - bc - ca} = (a+b+c)$$

$$11. a^4 - b^4 = (a^2)^2 - (b^2)^2 = (a^2 + b^2)(a^2 - b^2) \\ = (a^2 + b^2)(a+b)(a-b)$$

Condition of Divisibility for Algebraic Function

1. $a^n + b^n$ is exactly divisible by $a+b$ only when n is odd

Ex.: $a^3 + b^3 = (a+b)(a^2 - ab + b^2)$ is divisible by $a+b$, also $a^5 + b^5$ is divisible by $a+b$

2. $a^n + b^n$ is never divisible by $a-b$ (whether n is odd or even)

Ex.: $a^3 + b^3 = (a+b)(a^2 - ab + b^2)$ is not divisible by $(a-b)$

$a^7 + b^7$ is also not divisible by $(a-b)$

3. $a^n - b^n$ is exactly divisible by $(a-b)$ (whether n is odd or even)

Ex.: $a^9 - b^9$ is exactly divisible by $(a-b)$ also $a^{12} - b^{12}$ is also exactly divisible by $(a-b)$.

Factors of Composite Number

Composite numbers are the numbers which can be factorised into prime factors, or simply we can say that composite number are those numbers which are not prime.

For eg.: 8 is a composite number since it can be factorised into

$$8 = 2 \times 2 \times 2$$

Similarly 9 is also a composite number, i.e.

$$9 = 3 \times 3$$

Composite number = $P_1^{\lambda_1} \times P_2^{\lambda_2} \times P_3^{\lambda_3} \dots P_n^{\lambda_n}$ here,

$P_1, P_2, P_3 \dots P_n$ are prime numbers and $\lambda_1, \lambda_2,$

$\dots \lambda_n$ are their respective powers.

Factors of composite number = $(\lambda_1 + 1) \cdot (\lambda_2 + 1) \dots (\lambda_n + 1)$

For eg.: $18 = 2 \times 3 \times 3 = 2^1 \times 3^2$

Factors of $18 = (1 + 1) \times (2 + 1) = 2 \times 3 = 6$

Clearly it contains six factors 1, 2, 3, 6, 9 and 18

Factors of other Composite numbers $6 = 2^1 \times 3^1$

Factors = $(1 + 1) \times (1 + 1) = 4 = 1, 2, 3$ and 6

$72 = 2 \times 2 \times 2 \times 3 \times 3 = 2^3 \times 3^2$

Factors = $(3 + 1) \times (2 + 1) = 12$

- Ex. 1 Find the factors of composite number 360

$$\text{Sol.: } 360 = 2 \times 2 \times 2 \times 3 \times 3 \times 5 \\ = 2^3 \times 3^2 \times 5^1$$

$$\text{Factors} = (3 + 1)(2 + 1)(1 + 1) = 24.$$

- Ex. 2. Find all the factors of 120.

$$\text{Sol.: } 120 = 2 \times 2 \times 2 \times 3 \times 5 \\ = 2^3 \times 3^1 \times 5^1$$

$$\text{Factors} = (3 + 1)(1 + 1)(1 + 1) = 16.$$

□□□□

Counting Number of Zeros

Sometimes we come across problems in which we have to count number of zeros at the end of factorial of any number. For example

Number of zero at the end of 10!

$$10! = 10 \times 9 \times 8 \times 7 \times 6 \times 5 \times 4 \times 3 \times 2 \times 1$$

Here basically we have to count number of fives, because multiplication of five by any even number will result in 0 at the end of final product. In 10! we have 2 fives thus total number of zeros are 2.

Short Cut:

Counting number of zeros at the end of $n!$

$$\text{Value will be } \frac{n}{5} + \frac{n}{5^2} + \frac{n}{5^3} + \frac{n}{5^4} \dots$$

The integral value of this sum will be the total number of zeros.

- Ex. 1 Number of zeros at the end of 10!

$$\frac{10}{5} + \frac{10}{5^2} \dots \text{here integral value is } 2.$$

Note: Here $\frac{10}{5^2}$ is less than 1 so will not count it.

- Ex. 2 Number of zeros at the end of 100!

$$\text{Sol.: } \frac{100}{5} + \frac{100}{5^2} + \frac{100}{5^3} + \dots$$

integral value will be

$$20 + 4 = 24 \text{ zeros}$$

Ex.3 Number of zeros at the end of 126!

$$\text{Sol.: } \frac{126}{5} + \frac{126}{5^2} + \frac{126}{5^3} + \frac{126}{5^4}$$

integral value will be

$$25 + 5 + 1 = 31 \text{ zeros.}$$

Ex.4 Number of zeros at the end of 500!

$$\text{Sol.: } \frac{500}{5} + \frac{500}{5^2} + \frac{500}{5^3} + \frac{500}{5^4}$$

integral value will be

$$100 + 20 + 4 = 124 \text{ zeros.}$$

Ex.5 Number of zeros at the end of 1000!

$$\text{Sol.: } \frac{1000}{5} + \frac{1000}{5^2} + \frac{1000}{5^3} + \frac{1000}{5^4} + \frac{1000}{5^5}$$

$$200 + 40 + 8 + 1 = 249 \text{ zeros}$$

Ex.6 Number of zeros at the end of 50!

$$\text{Sol.: } \frac{50}{5} + \frac{50}{5^2} + \frac{50}{5^3} \dots$$

Integral value will be

$$10 + 2 = 12 \text{ zeros}$$

Ex.7 Number of zeros at the end of 90!

$$\text{Sol.: } \frac{90}{5} + \frac{90}{5^2} + \frac{90}{5^3} \dots$$

Integral value will be

$$18 + 3 = 21 \text{ zeros}$$

□□□□

Cyclicity

Cyclicity of a number is used mainly for the calculation of unit digits.

1. Cyclicity of 1.

In 1^n , unit digit will always be 1.

2. Cyclicity of 2.

$$2^1 = 2$$

$$2^2 = 4$$

$$2^3 = 8$$

$$2^4 = 16$$

$$2^5 = 32$$

$$2^6 = 64$$

$$2^7 = 128$$

$$2^8 = 256$$

After every four intervals it repeats so cycle of 2 is 2, 4, 8, 6.

Ex.1 Find unit digit of number 2^{54} .

Sol.: Here unit digit will repeat as 2, 4, 8, 6 after every four interval till 52 next 53 will be 2 and 54 will be 4. So unit digit will be 4.

Ex.2 Unit digit of 2^{323}

Sol.: Here 2, 4, 8, 6 will repeat after every four interval till 320 next digit will be 2, 4, **8**. So unit digit of 2^{323} will be 8.

Ex.3 Find unit digit of $12^{12} \times 22^{22}$

Sol.: Unit digit of 12^{12} will be 6 and 22^{22} will be 4. So unit digit of $12^{12} \times 22^{22}$ will be

$$6 \times 4 = 2 \text{ **4** ; 4 Ans.}$$

3. Cyclicity of 3.

$$3^1 = 3$$

$$3^2 = 9$$

$$3^3 = 27$$

$$3^4 = 81$$

$$3^5 = 243$$

$$3^6 = 729$$

$$3^7 = 2187$$

$$3^8 = 6561$$

After every four intervals 3, 9, 7 and 1 are repeated. So cycle of 3 is 3, 9, 7, 1.

Ex.1 Find unit digit of 3^{81} .

Sol.: Cycle of 3 is 3, 9, 7, 1 which repeats after every four interval till 3^{80} . So next unit digit will be 3.

Ex.2 Find unit digit of 133^{133} .

Sol.: Cycle of 3 is 3, 9, 7, 1 which repeats after every four intervals till 133^{132} . So next unit digit will be 3.

Ex.3 Find unit digit of $963^{63} \times 73^{73}$

Sol.: Unit digit of 963^{63} will be 7 and unit digit of 73^{73} will be 3. So unit digit of $963^{63} \times 73^{73}$ will be $7 \times 3 = 21$ i.e. 1 Ans.

Ex.4 Find unit digit of $122^{122} \times 133^{133}$

Sol.: Unit digit of 122^{122} will be 4 because cycle of 2 is 2, 4, 8, 6 and unit digit of 133^{133} will be 3. So unit digit of $122^{122} \times 133^{133}$ will be $4 \times 3 = 12$ i.e. 2 Ans.

4. Cyclicity of 4.

$$4^1 = 4$$

$$4^2 = 16$$

$$4^3 = 64$$

$$4^4 = 256$$

Cycle is 4, 6, i.e.

Unit digit of 4^n depends on value of n.

If n is odd unit digit is 4 and if n is even digit is 6.

Ex.1 Find unit digit of 4^{425} .

Sol.: Since 425 is odd number unit digit will be 4.

Ex.2 Find unit digit of 4^{1024} .

Sol.: Since 1024 is even number unit digit will be 6.

Ex.3 Find unit digit of $133^{63} \times 4^{49}$.

Sol.: Unit digit of 133^{63} is 7 and unit digit of 4^{49} is 4 so unit digit of $133^{63} \times 4^{49}$ will be $7 \times 4 = 28$ i.e. 8.

5. Cyclicity of 5.

$$5^1 = 5$$

$$5^2 = 25$$

$$5^3 = 125$$

$$5^4 = 625$$

Unit digit will always be 5.

6. Cyclicity of 6.

$$6^1 = 6$$

$$6^2 = 36$$

$$6^3 = 216$$

$$6^4 = 1296$$

Unit digit will always be 6.

Ex.1 Find unit digit of $4^{69} \times 6^5$

Sol.: Unit digit of 4^{69} is 4 and unit digit of 6^5 is 6 so unit digit of $4^{69} \times 6^5$ will be $4 \times 6 = 24$ i.e. 4.

Ex.2 Find unit digit of $144^{145} \times 126^{126}$.

Sol.: Unit digit of 144^{145} is 4 and unit digit of 126^{126} is 6. So unit digit of $144^{145} \times 126^{126}$ will be $4 \times 6 = 24$ i.e. 4.

7. Cyclicity of 7.

$$7^1 = 7$$

$$7^2 = 49$$

$$7^3 = 343$$

$$7^4 = 2401$$

$$7^5 = 16807$$

$$7^6 = 117649$$

$$7^7 = 823543$$

$$7^8 = 5764801$$

Cycle of 7 is 7, 9, 3, 1

Ex.1 Find unit digit of 17^{17} .

Sol.: Cycle of 7 repeats 7, 9, 3, 1 till 17^{16} next digit will be 7. So ans. is 7.

Ex.2 Find unit digit of $17^{17} \times 27^{27}$

Sol.: Unit digit of 17^{17} is 7 and unit digit of 27^{27} is 3. So unit digit of $17^{17} \times 27^{27}$ will be $7 \times 3 = 21$ i.e. 1.

Ex.3 Find unit digit of $17^{17} \times 27^{27} \times 37^{37}$

Sol.: Unit digit of 17^{17} is 7, unit digit of 27^{27} is 3 and unit digit of 37^{37} is 7. So unit digit of $17^{17} \times 27^{27} \times 37^{37}$ will be $7 \times 3 \times 7 = 147$ i.e. 7.

8. Cyclicity of 8.

$$8^1 = 8$$

$$8^2 = 64$$

$$8^3 = 512$$

$$8^4 = 4096$$

$$8^5 = 32768$$

So cycle of 8 is 8, 4, 2, 6.

Ex. 1 Find unit digit of 18^{18} .

Sol.: Cycle of 8 repeats 8, 4, 26 after every four intervals till 18^{16} next digits will be 8 and 4. So unit digit of 18^{18} will be 4.

Ex. 2 Find unit digit of $18^{18} \times 28^{28} \times 288^{288}$.

Sol.: Unit digit of 18^{18} is 4, unit digit of 28^{28} is 6, unit digit of 288^{288} is 6. So unit digit of $18^{18} \times 28^{28} \times 288^{288}$ will be $4 \times 6 \times 6 = 144$ i.e. 4.

9. Cyclicity of 9.

$$9^1 = 9$$

$$9^2 = 81$$

$$9^3 = 729$$

$$9^4 = 6561$$

Cycle of 9 is 9, 1.

In 9^n unit digit will be 9 if n is odd and unit digit will be 1 if n is even.

Ex. 1 Find unit digit of

$$11^{11} + 12^{12} + 13^{13} + 14^{14} + 15^{15}$$

Sol.: Unit digit of 11^{11} is 1

Unit digit of 12^{12} is 6

Unit digit of 13^{13} is 3

Unit digit of 14^{14} is 6

Unit digit of 15^{15} is 5

So unit digit of given sum will be

$$1 + 6 + 3 + 6 + 5 = 21 \text{ i.e. } 1.$$

Ex. 2 Find unit digit of

$$21^{21} \times 22^{22} \times 23^{23} \times 24^{24} \times 25^{25}$$

Sol.: 25^{25} will give 5 in unit place, when multiplied by any even number i.e. 0, 2, 4, 6, 8 it will give zero at unit place. So, zero will be the unit digit of given question.

Cyclicity table

1 : 1.

2 : 2, 4, 6, 8.

3 : 3, 9, 7, 1.

4 : 4, 6

5 : 5

6 : 6

7 : 7, 9, 3, 1.

8 : 8, 4, 2, 6.

9 : 9, 1

0 : 0

□□□□

Remainder Theorem

Remainder of expression $\frac{a \times b \times c}{n}$ [i.e. $a \times b \times c$

when divided by n] is equal to the remainder of

expression $\frac{a_n \times b_n \times c_n}{n}$ [i.e. $a_n \times b_n \times c_n$ when

divided by n], where

a_n is remainder when a is divided by n ,

b_n is remainder when b is divided by n , and

c_n is remainder when c is divided by n .

Ex. 1 Find the remainder of $15 \times 17 \times 19$ when divided by 7.

Sol.: Remainder of expression $\frac{15 \times 17 \times 19}{7}$ will

$$\text{be equal to } \frac{1 \times 3 \times 5}{7} = \frac{15}{7} = \frac{1}{7}.$$

i.e. 1.

On dividing 15 by 7 we get 1 as remainder

On dividing 17 by 7 we get 3 as remainder

On dividing 19 by 7 we get 5 as remainder

and combined remainder will be equal to

remainder of $\frac{15}{7}$ i.e. 1.

Ex. 2 Find remainder of expression $\frac{19 \times 20 \times 21}{9}$

will be equal to remainder of expression

$$\frac{1 \times 2 \times 3}{9} \text{ which is equal to 6.}$$

□□□□

Polynomial Theorem

This is very powerful theorem to find the remainder.

According to polynomial theorem.

$$(x+a)^n = x^n + nC_1 x^{n-1} a + nC_2 x^{n-2} a^2 + nC_3 x^{n-3} a^3 \dots nC_{n-1} x^1 a^{n-1} + a^n \quad \dots(1)$$

$$\therefore \frac{(x+a)^n}{x} =$$

$$\frac{(x^n + nC_1 x^{n-1} a + nC_2 x^{n-2} a^2 + nC_3 x^{n-3} a^3 + \dots nC_{n-1} x^1 a^{n-1} + a^n)}{x} \quad \dots(2)$$

remainder of expression (2) will be equal to

remainder of $\frac{a^n}{x}$ because rest of the term contains x are completely divisible by x .

Ex.1 Find the remainder of $\frac{9^{99}}{8}$.

$$\text{Sol.: } \frac{9^{99}}{8} = \frac{(8+1)^{99}}{8}$$

According to polynomial theorem remainder will be equal to remainder of

the expression $\frac{1^{99}}{8}$ which is equal to 1.

Ex.2 Find remainder of $\frac{8^{99}}{7}$

$$\text{Sol.: } \frac{8^{99}}{7} \Rightarrow \frac{(7+1)^{99}}{7} \Rightarrow \frac{1^{99}}{7} \text{ i.e. } 1.$$

Ex.3 Find remainder of $\frac{11 \times 13 \times 17}{6}$.

$$\text{Sol.: } \frac{11 \times 13 \times 17}{6} \Rightarrow \frac{5 \times 1 \times 5}{6} \Rightarrow \frac{1}{6} \Rightarrow 1.$$

[According to remainder theorem.]

Ex.4 Find remainder of $\frac{9^{100}}{7}$.

$$\begin{aligned} \text{Sol.: } \frac{9^{100}}{7} &\Rightarrow \frac{[7+2]^{100}}{7} \Rightarrow \frac{2^{100}}{7} \Rightarrow [3] \\ &\Rightarrow \frac{2^{99} \times 2}{7} = \frac{(2^3)^{33} \times 2}{7} \\ &\Rightarrow \frac{(7+1)^{33} \times 2}{7} = \frac{1 \times 2}{7} = 2. \end{aligned}$$

Ex.5 Find remainder of $\frac{9^{50}}{7}$.

$$\begin{aligned} \text{Sol.: } \frac{9^{50}}{7} &\Rightarrow \frac{(7+2)^{50}}{7} = \frac{2^{50}}{7} \Rightarrow \frac{(2^3)^{16} \times 2^2}{7} \\ &\Rightarrow \frac{(7+1)^{16} \times 4}{7} \Rightarrow \frac{1 \times 4}{7} \text{ i.e. } 4. \end{aligned}$$

Ex.6 Find remainder of $\frac{5^{100}}{7}$.

$$\begin{aligned} \text{Sol.: } \frac{5^{100}}{7} &= \left[\frac{3 \times 7 + 4}{7} \right]^{100} \Rightarrow \frac{(4)^{100}}{7} \\ &\Rightarrow \frac{2^{100}}{7} \Rightarrow \frac{(2^3)^{33} \times 2}{7} \Rightarrow \frac{(7+1)^{33} \times 2}{7} \Rightarrow \frac{1 \times 2}{7} \\ &\Rightarrow \text{Remainder is } 2. \end{aligned}$$

Ex.7 Find remainder of $\frac{3^{50}}{7}$.

$$\begin{aligned} \text{Sol.: } \frac{3^{50}}{7} &\Rightarrow \frac{(3^2)^{25}}{7} \Rightarrow \frac{(7+2)^{25}}{7} \Rightarrow \frac{2^{25}}{7} \\ &\Rightarrow \frac{(2^3)^8 \times 2}{7} = \frac{(7+1)^8 \times 2}{7} \Rightarrow \frac{1 \times 2}{7} \\ &\Rightarrow \text{Remainder is } 2. \end{aligned}$$

Ex.8 Find remainder of $\frac{3^{250}}{7}$.

$$\text{Sol.: } \frac{(3^2)^{125}}{7} \Rightarrow \frac{(7+2)^{125}}{7} \Rightarrow \frac{2^{125}}{7}$$

$$\frac{(2^3)^{41} \times 2^2}{7} \Rightarrow \frac{1 \times 4}{7}$$

⇒ Remainder is 4.

More On Remainders

Case-I

On dividing a number by a, b & c if we get a-k, b-k and c-k as remainder respectively then that number will be $n \times \text{LCM of } [a, b, c] - k$.

For ex (I): On dividing a number by 4, 5 & 6 we get 3, 4, & 5 as remainder. Find the number.

Sol.:

	4,	5,	6
Remainder	3,	4,	5,

which is equal to $(4-1)$, $(5-1)$, $(6-1)$,
so that number will be:
 $n \times \text{LCM of } (4, 5, 6) - 1$,
i.e. $60 - 1 = 59$.

Note: n such numbers are possible. Here we have taken n as 1. Other numbers are 119, 179, 239, etc. Where value of n is 2, 3, & 4 respectively.

Ex.2 On dividing a number by 5, 6 and 7 we get 3, 4 and 5 as remainder. Find the number.

Sol.:

	5,	6,	7
Remainder	3,	4,	5

which is equal to $(5-2)$, $(6-2)$, $(7-2)$
that number will be:
 $n \times \text{LCM of } (5, 6, 7) - 2 = 210 - 2 = 208$.

Note: Here we have taken value of n as 1.

Ex.3 On dividing a number by 4 and 5 we are getting 2 & 3 as remainders. Find the highest double digit such a number.

Sol.:

	4,	5
Remainder	2,	3

which is equal to $(4-2)$, $(5-2)$
that number will be:
 $n \times \text{LCM of } [4, 5] - 2$.

We get 18, 38, 58, 78, 98, 118 when value of n is 1, 2, 3, 4, 5 and 6 respectively. Highest double digit such number will be 98 Ans.

Ex.4 On dividing a number by 4, 5 and 6 we get 2, 3 and 4 as remainder find highest possible three digit such number.

Sol.:

	4,	5,	6
Remainder	2,	3,	4

which is equal to $(4-2)$, $(5-2)$, $(6-2)$,
that number will be:

$$n \times \text{LCM of } [4, 5, 6] - 2 = n \times 60 - 2$$

When $n = 1$ we get 58. Highest possible three digit such number will be 958.

Ex.5 On dividing a number by 5, 6 and 7 we get 3, 4 and 5 as remainder. Find highest possible three digit such number.

Sol.:

	5,	6,	7
Remainder	3,	4,	5

which is equal to $(5-2)$, $(6-2)$, $(7-2)$
that number will be:

$$n \times \text{LCM } (5, 6, 7) - 2 = n \times 210 - 2$$

Highest possible three digit number will be 838.

Case-II

On dividing a number a, b and c if we get k as remainder always, then that number will be

$$n \times \text{LCM of } (a, b, c) + k.$$

Ex.1 On dividing a number by 5, 6 and 7 if we get 2 as remainder always, find that number

Sol.: That number will be

$$n \times \text{LCM of } [5, 6, 7] + 2$$

$$\Rightarrow 210 + 2 = 212.$$

Ex.2 On dividing a number by 6 and 7 we get 4 as remainder always, find the highest possible three digit such number.

Sol.: $n * \text{LCM} [6, 7] + 4$
 $= n \times 42 + 4$; three digit
highest possible such number will be
 $966 + 4 = 970$ Ans.

Case-III

If a number after adding k is exactly divisible by a, b and c then that number will be.

$$n \times \text{LCM} (a, b, c) - k$$

Ex.1 Find a number which after adding 5 is divisible by 6 and 7.

Sol.: That number will be
 $n \times \text{LCM} \text{ of } (6, 7) - 5$
if $n = 1$ then
 $42 - 5 = 37$.

Ex.2 Find a number which after adding 7 is divisible by 10, 11 and 12.

Sol.: That number will be
 $n \times \text{LCM} \text{ of } [10, 11, 12] - 7$
if $n = 1$ then
 $660 - 7 = 653$ Ans.



Squares of Numbers

Squares of numbers are frequently used for calculations on various types of problems. It is advisable to remember square of at least first thirty numbers.

$1^2 = 1$	$11^2 = 121$
$2^2 = 4$	$12^2 = 144$
$3^2 = 9$	$13^2 = 169$
$4^2 = 16$	$14^2 = 196$
$5^2 = 25$	$15^2 = 225$
$6^2 = 36$	$16^2 = 256$
$7^2 = 49$	$17^2 = 289$
$8^2 = 64$	$18^2 = 324$
$9^2 = 81$	$19^2 = 361$
$10^2 = 100$	$20^2 = 400$

From following table we come to know that square of a number always ends with 0, 1, 4, 5, 6 & 9 as unit digit.

Square of a number can never have 2, 3, 7 & 8 in its unit place.

On observing squares of numbers between 21 to 29 we get following pattern.

$21^2 = 4$	41	$29^2 = 8$	41
$22^2 = 4$	84	$28^2 = 8$	84
$23^2 = 5$	29	$27^2 = 7$	29
$24^2 = 5$	76	$26^2 = 6$	76
$25^2 = 6$	25		

Last two digits are common.

Shortcuts for calculation of squares of numbers between 41 to 50.

Ex.1 Find square of 48?

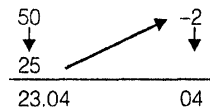

Square of -2 is equal to 04 so we have written 04 in last two places. Square of 5 is 25, from which we added -2 and get 23. So square of 48 is 2304.

Ex.2 $44^2 = ?$

Sol.: 44 is -6 distance away from 50

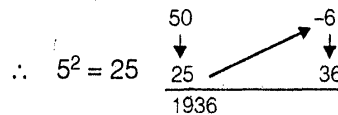

Ex.3 $42^2 = ?$

Sol.: 42 is -8 distance away from 50

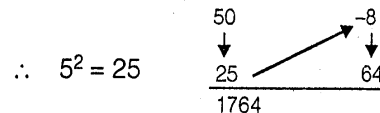

Ex.4 $41^2 = ?$

Sol.: 41 is -9 distance away from 50

$$\begin{array}{r} 50 \\ \downarrow \\ \therefore 5^2 = 25 \quad \frac{25}{1681} \end{array} \begin{array}{l} \nearrow \\ -9 \\ \downarrow \\ 81 \end{array}$$

1681 Ans.

Similarly, we can find squares of other square of number between 50 & 60.

Ex.1 $53^2 = ?$
 Sol.: 53 is +3 distance away from 50

$$\begin{array}{r} 50 \\ \downarrow \\ \therefore 5^2 = 25 \quad \frac{25}{2809} \end{array} \begin{array}{l} \nearrow \\ +3 \\ \downarrow \\ 09 \end{array}$$

Ex.2 $56^2 = ?$
 Sol.: 56 is +6 distance away from 50

$$\begin{array}{r} 50 \\ \downarrow \\ \therefore 5^2 = 25 \quad \frac{25}{3136} \end{array} \begin{array}{l} \nearrow \\ +6 \\ \downarrow \\ 36 \end{array}$$

Ex.3 $58^2 = ?$
 Sol.: 58 is +8 distance away from 50

$$\begin{array}{r} 50 \\ \downarrow \\ \therefore 5^2 = 25 \quad \frac{25}{3364} \end{array} \begin{array}{l} \nearrow \\ +8 \\ \downarrow \\ 64 \end{array}$$

Ex.4 $59^2 = ?$
 Sol.: 59 is +9 distance away from 50

$$\begin{array}{r} 50 \\ \downarrow \\ \therefore 5^2 = 25 \quad \frac{25}{3481} \end{array} \begin{array}{l} \nearrow \\ +9 \\ \downarrow \\ 81 \end{array}$$

Similarly, we can find square of other numbers between 50 and 60 speedily.



Observation

Square of two digit number having 5 in unit places can be calculated very easily. n5 here n may 1 to 9.

$$(n5)^2 = [n * (n + 1)]25$$

Ex.2 $(15)^2 = ?$
 $15^2 =$
 $1 \times (1 + 2)25 = 225$

Sol.: $25^2 = ?$
 $(25)^2 = [2 \times (2 + 1)]25$
 $\Rightarrow 625$

Ex.3 $45^2 = ?$
 Sol.: $[4 \times (4 + 1)]25 = 2025$

Ex.4 $65^2 = ?$
 Sol.: $[6 \times (6 + 1)]25 = 4225$

Ex.5 $85^2 = ?$
 Sol.: $[8 \times (8 + 1)]25 \Rightarrow 7225$

Ex.6 $95^2 = ?$
 Sol.: $[9 \times (9 + 1)]25 \Rightarrow 9025$

Some Multiplication Techniques

Multiplication usually takes longer time than addition and subtraction. While solving problems related to ratio and proportion and percentage we have to multiply numbers in and around 100 frequently. Here, we have some tricks to make it a very enjoyable way to calculate the number.

Case-I

When both numbers are greater than 100.

Ex.1 $106 \times 103 = ?$
 Sol.: 106 is + 6 distance away from 100 and 103 is + 3 distance away from 100.

$$\begin{array}{r} 106 \\ \times \\ 103 \\ \hline 109 \end{array} \begin{array}{l} \nearrow \\ +6 \\ \downarrow \\ 18 \end{array}$$

So 106×103 will be equal to 10918. Here either we are adding 106 & 3 or we are adding 103 & 6, in both case we will get 109.

Ex.2 $104 \times 105 = ?$

Sol.: $\begin{array}{r} 104 \\ \times \\ 105 \\ \hline 109 \end{array} \begin{array}{l} \nearrow \\ +4 \\ \downarrow \\ 20 \end{array}$
 $= 10920$ Ans.

Ex.3 $108 \times 111 = ?$

Sol.:
$$\begin{array}{r} 108 \quad +8 \\ \times \quad \times \\ 111 \quad +11 \\ \hline 119 \quad 88 \\ = 11988 \text{ Ans.} \end{array}$$

Ex.4 $121 \times 105 = ?$

Sol.:
$$\begin{array}{r} 121 \quad +21 \\ \times \quad \times \\ 105 \quad +5 \\ \hline 126 + 1 \quad 1/05 \\ = 12705 \end{array}$$

Note:

Multiplication of 21 and 5 will be 105, we will write 05 in first two place and 1 will become carry which will be added to (105 + 21) and finally we get 12705 as answer.

Ex.5 $118 \times 118 = ?$

Sol.:
$$\begin{array}{r} 118 \quad +18 \\ \times \quad \times \\ 118 \quad +18 \\ \hline 139 \quad 3/24 \\ = 13924 \text{ Ans.} \end{array}$$

Ex.6 $117 \times 177 = ?$

Sol.:
$$\begin{array}{r} 117 \quad +17 \\ \times \quad \times \\ 117 \quad +17 \\ \hline 136 \quad 2/89 \\ = 13689 \text{ Ans.} \end{array}$$

Ex.7 $115 \times 108 = ?$

Sol.:
$$\begin{array}{r} 115 \quad +15 \\ \times \quad \times \\ 108 \quad +08 \\ \hline 124 \quad 1/20 \\ = 12420 \text{ Ans.} \end{array}$$

Ex.8 $125 \times 103 = ?$

Sol.:
$$\begin{array}{r} 125 \quad +25 \\ \times \quad \times \\ 103 \quad +03 \\ \hline 128 \quad 75 \\ = 12875 \text{ Ans.} \end{array}$$

Ex.9 $111 \times 107 = ?$

Sol.:
$$\begin{array}{r} 111 \quad +11 \\ \times \quad \times \\ 107 \quad +7 \\ \hline 118 \quad 77 \\ = 11877 \text{ Ans.} \end{array}$$

Ex.10 $113 \times 112 = ?$

Sol.:
$$\begin{array}{r} 113 \quad +13 \\ \times \quad \times \\ 112 \quad +12 \\ \hline 126 \quad 1/52 \\ = 12652 \text{ Ans.} \end{array}$$

Case-II

When both numbers are less than 100.

Ex.1 $92 \times 93 = ?$

Sol.: 92 is -8 distance away from 100, and 93 is -7 distance away from 100. thus

$$\begin{array}{r} 92 \quad -8 \\ \times \quad \times \\ 93 \quad -7 \\ \hline 85 \quad 56 \end{array}$$

= 8556 Ans.

Ex.2 $88 \times 95 = ?$

Sol.: 88 is -12 distance away from 100, and 95 is -5 distance away from 100, thus

$$\begin{array}{r} 88 \quad -12 \\ \times \quad \times \\ 95 \quad -5 \\ \hline 83 \quad 60 \end{array}$$

= 8360 Ans.

Note: Here we are adding 95 and -12 or 88 and -5.

Ex.3 $93 \times 87 = ?$

Sol.:
$$\begin{array}{r} 93 \quad -7 \\ \times \quad \times \\ 87 \quad -13 \\ \hline 80 \quad 91 \\ = 8091 \text{ Ans.} \end{array}$$

Ex.4 $89 \times 88 = ?$

Sol.:
$$\begin{array}{r} 89 \quad -11 \\ \times \quad \quad \times \\ 88 \quad -12 \\ \hline 78 \quad 1/32 \end{array}$$

Note: Here we get 132 by multiplying -11 and -12, where 1 is carry. We have to add 1 with 88 and -11 or 89 and -12 and we get desired result as 7832.

Ex.5 $97 \times 94 = ?$

Sol.:
$$\begin{array}{r} 97 \quad -3 \\ \times \quad \quad \times \\ 94 \quad -6 \\ \hline 91 \quad 18 \end{array}$$

= 9118 Ans.

Ex.6 $85 \times 98 = ?$

Sol.:
$$\begin{array}{r} 85 \quad -15 \\ \times \quad \quad \times \\ 98 \quad -2 \\ \hline 83 \quad 30 \end{array}$$

= 8330 Ans.

Ex.7 $94 \times 98 = ?$

Sol.:
$$\begin{array}{r} 94 \quad -6 \\ \times \quad \quad \times \\ 98 \quad -2 \\ \hline 92 \quad 12 \end{array}$$

= 9212 Ans.

Ex.8 $82 \times 82 = ?$

Sol.:
$$\begin{array}{r} 82 \quad -18 \\ \times \quad \quad \times \\ 82 \quad -18 \\ \hline 67 \quad 3/24 \end{array}$$

= 6734 Ans.

[Note: Here we have added 3 while adding 82 & -18 & get 6734]

Case-III

When one number is greater than 100 and another number is less than 100.

Ex.1 $105 \times 93 = ?$

Sol.: 105 is +5 distance away from and 93 is -7 distance away from 100.

$$\begin{array}{r} 105 \quad +5 \\ \times \quad \quad \times \\ 93 \quad -7 \\ \hline 98 \quad 00 \\ 9800 \quad -35 \\ \hline 9765 \end{array}$$

Here we have to subtract 35 from 9800 and final result will be. 9765.

Ex.2 $111 \times 11 = ?$

$$\begin{array}{r} 111 \quad +11 \\ \times \quad \quad \times \\ 88 \quad -12 \\ 99 \quad 00 \\ \hline -132 \end{array}$$

9900

-132

9768

Here we have to subtract 132 from 9900 and final result will be 9768.



Solved Examples

- The last digit of the number obtained by multiplying the numbers $81 \times 82 \times 83 \times 84 \times 85 \times 86 \times 87 \times 88 \times 89$ will be
 (a) 0 (b) 9
 (c) 7 (d) 2

Ans: (a)

Last digit will be multiplication of $1 \times 2 \times 3 \times 4 \times 5 \times 6 \times 7 \times 8 \times 9$

Since 5 and 2 are given here, their multiplication will result in zero as last digit.

- The sum of the digits of a two-digit number is 10, while when the digits are reversed, the number decreases by 54. Find the the changed number.

- (a) 28 (b) 19
 (c) 37 (d) 46

Ans: (a)

Going through options we get $82 - 28 = 54$

3. The sum of two numbers is 15 and their geometric mean is 20% lower than their arithmetic mean. Find the numbers.

(a) 11, 4 (b) 12, 3
(c) 13, 2 (d) 10, 5

Ans: (b)

Going through options only 12 and 3 satisfies the condition

$$AM = \frac{12+3}{2} = 7.5$$

GM = $\sqrt{12 \times 3} = 6$ which is 20% less than 7.5.

4. If A381 is divisible by 11, find the value of the smallest natural number A?

(a) 5 (b) 6
(c) 7 (d) 9

Ans: (c)

A 381 is divisible by 11 if and only if $(A + 8) - (3 + 1)$ is divisible by 11.

So, A=7 Satisfies the condition

5. If 381A is divisible by 9, find the value of smallest natural number A?

(a) 5 (b) 6
(c) 7 (d) 9

Ans: (b)

381 A is divisible by 9

So $3+8+1+A=12+A$ is divisible by 9

So A=6

6. Find the LCM of $5/2$, $8/9$, $11/14$.

(a) 280 (b) 360
(c) 420 (d) None of these

Ans: (d)

$$\text{LCM of fraction} = \frac{\text{LCM of numerators}}{\text{H. C. F of Denominators}}$$

Here, $5/2$, $8/9$, $11/14$, so

$$\text{LCM} = \frac{\text{LCM of } (5, 8, 11)}{\text{HCF of } (2, 9, 14)} = \frac{440}{1} = 440$$

7. A number 15B is divisible by 6. Which of these will be true about the positive integer B?

(a) B will be even
(b) B will be odd
(c) B will be divisible by 6
(d) Both a and c

Ans: (d)

15 B is divisible by 6

So B should be even number

also $1+5+B$ should be divisible by 3 only 6 is the value for B

8. Find the number of zeros at the end of 100!

(a) 24 (b) 28
(c) 26 (d) None of these

Ans: (a)

100!

$$\text{No. of Zeros} \Rightarrow \frac{100}{5} + \frac{100}{5^2} + \frac{100}{5^3} + \dots$$

$$(\text{Whole number of}) = 20 + 4 = 24$$

9. If $146!$ is divisible by 5^n , then find the maximum value of n.

(a) 34 (b) 35
(c) 36 (d) 37

Ans: (b)

$$\frac{146}{5^n} \text{ then highest value of } 5 \text{ will be}$$

$$\frac{146}{5} + \frac{146}{5^2} + \frac{146}{5^3} + \dots = 29 + 5 + 1 = 35$$

10. Find the number of divisors of 1420.

(a) 14 (b) 15
(c) 13 (d) 12

Ans: (d)

$$1420 = 142 \times 10 = 71 \times 2 \times 2 \times 5 = 2^2 \times 5^1 \times 71^1$$

$$\text{No. of divisor} = (2+1)(1+1)(1+1) = 12$$

11. Find the HCF and LCM of the polynomials

$$(x^2 - 5x + 6) \text{ and } (x^2 - 7x + 10).$$

(a) $(x-2), (x-2)(x-3)(x-5)$

(b) $(x-2), (x-2)(x-3)$

(c) $(x-3), (x-2)(x-3)(x-3)$

(d) None of these

Ans: (a)

$$x^2 - 5x + 6 = (x-3)(x-2)$$

$$x^2 - 7x + 10 = (x-5)(x-2)$$

So, HCF = $(x-2)$

LCM = $(x-2)(x-3)(x-5)$

Directions for questions 12-14: Given two different prime numbers P and Q. Find the number of divisors of the following:

12. P.Q.

- (a) 2 (b) 4
(c) 6 (d) 8

Ans: (b)

$$P.Q = P^1 \times Q^1$$

$$\Rightarrow \text{Number of divisor} = (1+1)(1+1) = 4$$

13. P².Q

- (a) 2 (b) 4
(c) 6 (d) 8

Ans: (c)

$$P^2Q$$

Number of divisor = $(2+1)(1+1) = 4$

14. P³Q²

- (a) 2 (b) 4
(c) 6 (d) 12

Ans: (d)

$$P^3Q^2$$

Number of divisors = $(3+1)(2+1) = 12$

15. A milkman has three different qualities of milk. 403 gallons of 1st quality, 465 gallons of 2nd quality and 496 gallons of 3rd quality. Find the least possible number of bottles of equal size in which different milk of different qualities can be filled without mixing?

- (a) 34 (b) 46
(c) 26 (d) 44

Ans: (d)

It is given that gallons of

1st quality : 403

IInd quality : 465

III rd quality : 496

least number of gallons will be in size of 403, 465 and 496

$$403 = 13 \times 31$$

$$465 = 15 \times 31$$

$$496 = 16 \times 31$$

HCF = 31 so we required 13+15+16 gallons.

16. What is the greatest number of 4 digits that when divided by any of the numbers 6, 9, 12, 17 leaves a remainder of 1?

- (a) 9997 (b) 9793
(c) 9895 (d) 9487

Ans: (b)

LCM of 6, 9, 12, 17 = 612

greatest number of 4 digit divisible by 612 is 9792, to get remainder 1 number should be 9792+1

17. Which of the following is not a perfect square?

- (a) 100858 (b) 3, 25, 137
(c) 945723 (d) All of these

Ans: (a)

Square of number never ends up with 2, 3, 7, 8

18. Which of the following can never be in the ending of a perfect square?

- (a) 6 (b) 00
(c) 000 (d) 5

Ans: (c)

19. The LCM of 5, 8, 12, 20 will not be a multiple of

- (a) 3 (b) 9
(c) 8 (d) 5

Ans: (b)

LCM of 5, 8, 12, 20 will not be a multiple of 9

20. The LCM of $(16 - x^2)$ and $(x^2 + x - 6)$ is
 (a) $(x-3)(x+3)(4-x^2)$ (b) $4(4-x^2)(x+3)$
 (c) $(16-x^2)(x-3)$ (d) None of these

Ans: (d)

$$16 - x^2 = (4-x)(4+x)$$

$$(x^2 + x - 6) = (x+3)(x-2)$$

$$\text{LCM will } (16 - x^2)(x^2 + x - 6)$$

21. GCD of $x^2 - 4$ and $x^2 + x - 6$ is
 (a) $x + 2$ (b) $x - 2$
 (c) $x^2 - 2$ (d) $x^2 + 2$

Ans: (b)

$$x^2 - 4 = (x-2)(x+2)$$

$$(x^2 + x - 6) = (x+3)(x-2)$$

$$\text{GCD} = (x-2)$$

22. Decompose the number 20 into two terms such that their product is the greatest.
 (a) $x_1 = x_2 = 10$ (b) $x_1 = 5, x_2 = 15$
 (c) $x_1 = 8, x_2 = 12$ (d) none of these

Ans: (a)

If $x+y = \text{constant}$ then xy will be maximum when $x=y$

$$\text{here, } x_1 + x_2 = 20$$

$$x_1 = x_2 = 10$$

23. Which of the following can be a number divisible by 24?
 (a) 4, 32, 15, 604 (b) 25, 61, 284
 (c) 13, 62, 480 (d) None of these

Ans: (c)

A number divisible by 24 will be divisible by 3 and 8

Only 1362480 satisfies the divisibility criteria

24. For a number to be divisible by 88, it should be
 (a) Divisible by 22 and 8
 (b) Divisible by 11 and 8
 (c) Divisible by 11 and thrice by 2
 (d) Both b and c

Ans: (b)

A number to be divisible by 88 it should be divisible by 8 and 11 because 8 and 11 are co prime numbers whose multiplication gives 88.

25. Find the GCD of the polynomials $(x+3)^2(x-2)$, $(x+1)^2$ and $(x+1)^3(x+3)(x+4)$.
 (a) $(x+3)^3(x+1)^2(x-2)(x+4)$
 (b) $(x+3)(x-2)(x+1)(x+4)$
 (c) $(x+3)(x+1)^2$
 (d) None of these

Ans: (c)

GCD of $(x+3)(x-2)(x+1)^2$ and

$(x+1)^3(x+3)(x+4)$ will be $(x+3)(x+1)^2$

26. Find the LCM of $(x+3)(6x^2+5x-4)$ and $(2x^2+7x+3)(x+3)$
 (a) $(2x+1)(x+3)(3x+4)$
 (b) $(4x^2-1)(x+3)^2(3x+4)$
 (c) $(4x^2-1)(x+3)(3x+4)$
 (d) $(2x-1)(x+3)(3x+4)$

Ans: (b)

$$(x+3)(6x^2+5x-4) = (x+3)(2x-1)(3x+4)$$

$$(2x^2+7x+3)(x+3) = (2x+1)(x+3)(x+3)$$

$$\text{LCM} = (2x+1)(2x-1)(x+3)^2(3x+4)$$

$$= (4x^2-1)(x+3)^2(3x+4)$$

27. The product of three consecutive natural numbers, the first of which is an even number, is always divisible by
 (a) 12 (b) 24
 (c) 6 (d) All of these

Ans: (d)

Three consecutive number will be $n(n+1)(n+2)$ if n is even number then $(n+2)$ will also be an even number and one of them will be divisible by 3. Hence number is always divisible by 12. for example if $n=2$ then $2 \cdot 3 \cdot 4 = 24$ if $n=4$ then $4 \cdot 5 \cdot 6 = 120$

28. Find the pairs of natural numbers whose least common multiple is 78 and the greatest common divisor is 13.

- (a) 58 and 13 or 16 and 29
 (b) 38 and 23 or 36 and 49
 (c) 18 and 73 or 56 and 93
 (d) 78 and 13 or 26 and 39

Ans: (d)

LCM = 78 and GCD = 13

Clearly 13, 78 and 26, 39 are the two numbers

29. Find two natural numbers whose sum is 85 and the least common multiple is 102.

- (a) 30 and 55 (b) 17 and 68
 (c) 35 and 55 (d) 51 and 34

Ans: (d)

Sum $x+y=85$

LCM = 102

only numbers are 51 and 34

30. What digits should be put in place of c in $38c$ to make it divisible by

- (1) 2 (2) 3
 (3) 4 (4) 5
 (5) 6 (6) 9
 (7) 10

Ans: 38c

(1) → to make it divisible by 2, c should be 0, 2, 4, 6, 8

(2) → to make it divisible by 3, c should be 1, 4, 7

(3) → to make it divisible by 4, c should be 0, 4, 8

(4) → to make it divisible by 5, c should be 0, 5

(5) → to make it divisible by 6, c should be 4

(6) → to make it divisible by 9, c should be 7

(7) → to make it divisible by 10, c should be 0



Solved Examples

1. Fill in the blank indicated by a star in the number 4^*56 so as to make it divisible by 33
 (a) 3 (b) 4
 (c) 5 (d) None of these

Ans. (a)

4^*56 is divisible by 33 if and only if it is divisible by 3 and 11.

4^*56 will be divisible by 3 if * will be equal to 0, 3, 6, 9

4^*56 is divisible by 11 if $(4 + 5) - (* + 6)$ will be divisible by 11 so * should be 3.

2. Find the least number which being divided by 9, 12, 16 and 30 leaves in each case a remainder 3?

- (a) 623 (b) 723
 (c) 728 (d) None of these

Ans. (b)

LCM of 9, 12, 16 and 30 is 720 so required number is $LCM+3 = 723$

3. Find the number which being increased by 1 will be exactly divisible by 17, 22, 33 and 102
 (a) 1131 (b) 1121
 (c) 1001 (d) None of these

Ans. (b)

LCM of 17, 22, 33 and 102 is 1122

So the given number is $1122 - 1 = 1121$

4. Find the greatest number less than 10000 which is divisible by 48, 60 and 64
 (a) 9600 (b) 8500
 (c) 7600 (d) none of these

Ans. (a)

The required number will be the largest four digit number in form of $n \times (LCM)$ of 48, 60 and 64 LCM of 48, 60 and 64 is 960

So the largest four digit number will be 9600

5. Find the least multiple of 11 which when divided by 8, 9, 12, 14 leaves 4 as remainder in each case.

- (a) 1012 (b) 1037
 (c) 1090 (d) none of these

Ans. (a)

The number is divisible by 11 and can be written in form $n(\text{LCM}) + 4$, LCM of 8, 9, 12, 14 is 504

So the number may be 508 & 1012 but 508 is not divisible by 11 so it is 1012

6. Find the greatest number of four digit which when divided by 15, 20, 28 leaves in each case a remainder 2?
 (a) 9662 (b) 9077
 (c) 1090 (d) none of these

Ans. (a)

The required number will be $(n \times \text{LCM}) + 2$
 LCM of 15, 20, 28 is 420

So greatest number divisible by 420 is 9660
 (Four digit number)

So required number will be 9662

7. Find the two numbers of 3 digits each of whose GCF is 310 and LCM is 1860
 (a) 620, 930 (b) 240, 540
 (c) 720, 1030 (d) none of these

Ans. (a)

Going by options we can determine that only option (a) satisfies the given condition.

8. The LCM of two number is 12 times their HCF. The sum of HCF and LCM is 403. If one number is 93 find the other.
 (a) 134 (b) 124
 (c) 128 (d) none of these

Ans. (b)

It is given that $\text{LCM} = 12 \times \text{HCF}$

also $\text{LCM} + \text{HCF} = 403$

So, $13 \times \text{HCF} = 403, \Rightarrow \text{HCF} = 31$

$\text{LCM} = 372$ also we know that $\text{HCF} \times \text{LCM} = \text{Number}(1) \times \text{Number}(2)$

$\text{HCF} \times \text{LCM} = \text{Number}(1) \times \text{Number}(2)$

$31 \times 372 = 93 \times N_2 \quad \therefore N_2 = 124$

9. I have to spend $\frac{1}{10}$ of my income on house rent, $\frac{1}{10}$ of remainder on conveyance $\frac{1}{3}$ of further remainder on children's education

after which I have Rs. 648 left over. What is my income?

- (a) Rs. 1200 (b) Rs. 1400
 (c) Rs. 1700 (d) none of these

Ans. (a) One alternate method

Let I have x rupees

After spending $\frac{1}{10}$ of it on house rent I have

$\frac{9x}{10}$. Now out of $\frac{9x}{10}$ I spent $\frac{1}{10}$ of it i.e.,

$\frac{9}{100}x$ on conveyance so remainder will be

$$\frac{9}{10}x - \frac{9}{100}x = \frac{81x}{100}$$

Further I spent $\frac{1}{3}$ of $\frac{81x}{100}$ i.e. $\frac{27x}{100}$ into

children's education now I have $\frac{54x}{100}$

$$\text{So, } \frac{54x}{100} = 648, \quad x = 1200$$

10. A man had two sons. To the elder he gave

$\frac{5}{11}$ of his property, to the younger $\frac{5}{11}$ of

remainder, the rest to the widow. Find the Share of the sons if the widow gets Rs. 3600.

- (a) Rs. 1200, 1000 (b) Rs. 6000, 2000
 (c) Rs. 7500, 1000 (d) none of these

Ans. (d)

Younger son gets

$$3600 \times \left(\frac{1}{1 - \frac{5}{11}} \right) \times \frac{5}{11} = \text{Rs. } 3000$$

Elder son gets

$$3000 \times \left(\frac{1}{1 - \frac{5}{11}} \right) = \text{Rs. } 5500$$

□□□□



Average

The average of a number is a measure of central tendency of a set of Numbers. In other words, it is an estimate of where the center point of a set of number lies.

$$\text{Average} = \frac{\text{sum of set of } N \text{ number}}{N}$$

This also means

$$\text{Average} \times N = \text{sum of set of numbers.}$$

Illustration: Let suppose the score of sachin Tendular in last 5 matches are 90, 150, 10, 70, 45, then average score will be

$$Av = \frac{90+150+10+70+45}{5} = \frac{365}{5} = 73$$

Concept of Weighted Average

When we have two or more groups whose individual averages are known, then to find the combined average of the all elements of all the groups we use weighted average. Thus, if we have K groups with Averages A_1, A_2, \dots, A_k and having n_1, n_2, \dots, n_k elements then the weighted average is given by formula:

$$A_w = \frac{n_1A_1 + n_2A_2 + n_3A_3 + \dots + n_kA_k}{n_1 + n_2 + n_3 + \dots + n_k}$$

Illustration: Let Rahuls average score in 5 test of maths is 75, 4 test of physics is 80 and 3 test of

chemistry is 90 the find the overall average marks obtained by him in these subjects.

Here we have to calculate weighted average which can be calculated by

$$A_w = \frac{75 \times 5 + 80 \times 4 + 90 \times 3}{5 + 4 + 3} = \frac{965}{12}$$

$$= 80.4 \text{ approx}$$

Sometimes weighted average is used to find merit order of students in competition examinations. Like for examples if in a Pre Engineering Test (PET) sum of scores obtained by two students are equal then their weighted average is calculated to find order of ranking

Illustration: Rahul & Ravi Scored following marks in PET exam.

Subject	Rahul	Ravi
Maths	90	80
Physics	70	60
Chemistry	60	80

In this case total scores are equal for Rahul and Ravi. To find ranking weights can be given in following manner. Maths 3, Physics 2, and Chemistry 1 in this case weighted average can be calculated as

$$A_w(\text{Rahul}) = \frac{90 \times 3 + 70 \times 2 + 60 \times 1}{6}$$

$$= \frac{470}{6} = 78.33$$

$$A_w(\text{Ravi}) = \frac{80 \times 3 + 60 \times 2 + 80 \times 1}{6}$$

$$= \frac{440}{6} = 73.33$$

Here weighted average of Rahul is more than weighted average of Ravi, so Rahul will be preferred in ranking.

Some Important Results

1. Average of first ten natural Number is

$$\frac{1+2+3+\dots+9}{10} = \frac{55}{10} = 5.5$$

2. Average of first ten whole Number is

$$\frac{0+1+2+3+\dots+9}{10} = \frac{45}{10} = 4.5$$

3. The average of first ten even number is

$$\frac{2+4+6+\dots+20}{10} = \frac{110}{10} = 11$$

4. The average of first 10 odd number is

$$\frac{1+3+5+\dots+19}{10} = \frac{100}{10} = 10$$

5. Average of first ten prime number is

$$\frac{2+3+5+7+11+13+17+19+23+29}{10}$$

$$= \frac{129}{10} = 12.9$$

6. The average of first ten composite number is:

$$\frac{4+6+8+9+10+12+14+15+16+18}{10}$$

$$= \frac{112}{10} = 11.2$$

7. The average of first ten odd prime number is

$$\frac{3+5+7+11+13+17+19+23+29+31}{10}$$

$$= \frac{158}{10} = 15.8$$

□□□□



Solved Example

1. The average age of 24 students and the principal is 15 years. When the principal's age is excluded, the average age decreases by 1 year. What is the age of principal?

- (a) 38 (b) 40
(c) 39 (d) Data inadequate

Ans. (c)

Average age of 24 students

$$= \frac{\text{sum of ages of 24 students}}{24}$$

$$\Rightarrow 14 = \frac{\text{sum of ages of 24 students}}{24}$$

$$\therefore \text{sum of ages of 24 students} = 24 \times 14$$

$$= 336 \text{ years}$$

Let the Age of principal be x year

Then, average age of 24 students and the principal

$$= \frac{\text{Sum of ages of 24 students \& principal}}{25}$$

$$\Rightarrow 15 = \frac{336+x}{25}$$

$$\Rightarrow x = 25 \times 15 - 336 = 39 \text{ years}$$

2. The average weight of 3 men A, B and C is 84 kg. Another man D joins the group and the average now becomes 80 kg. If another man E, whose weight is 3 kg more than that of D, replaces A then the average weight of B, C, D and E becomes 78 kg. The weight of A is
- (a) 70kg. (b) 72 kg.
(c) 79 kg. (d) 78 kg

Ans. (c)

Sum of weight of A, B and C

$$= 3 \times 84 = 252 \text{ kg}$$

sum of weights of A, B, C and D

$$= 4 \times 80 = 320 \text{ kg}$$

weight of D = $320 - 252 = 68 \text{ kg}$

\therefore weight of E = $68 + 3 = 71 \text{ kg}$

Now, sum of weight of A, B, C, D and E

$$= 320 + 71 = 391 \text{ kg}$$

sum of weight of B, C, D and E

$$= 4 \times 78 = 312 \text{ kg}$$

\therefore weight of A = $391 - 312 = 79 \text{ kg}$

3. Three years ago, the average age of A, B and C was 27 years and that of B and C, 5 years ago was 20 years. A's present age is
- (a) 30 years (b) 35 years
(c) 40 years (d) 48 years

Ans. (c)

The sum of ages of A, B and C, three years ago = $27 \times 3 = 81 \text{ years}$

Present sum of ages of A, B, and C

$$= 81 + 3 \times 3 = 90 \text{ years}$$

sum of ages of B and C, 5 years ago

$$= 20 \times 2 = 40 \text{ years}$$

Present sum of ages of B, and C

$$= 40 + 2 \times 5 = 50 \text{ years}$$

\therefore A's Present age = $90 - 50 = 40 \text{ years}$

4. Vijay Tendulkar has certain average for 9 innings. In the tenth inning, he scores 100 runs thereby increasing his average by 8 runs. His new average is
- (a) 20 (b) 24
(c) 28 (d) 32

Ans. (c)

Let the old average and new average by x and y respectively

$$\text{Then, } y = x + 8 \quad \dots(i)$$

$$\text{and } y = \frac{9x + 100}{10} \quad \dots(ii)$$

From (i) and (ii) we get

$$10(x + 8) = 9x + 100$$

$$\Rightarrow x = 20$$

$$\therefore y = 20 + 8 = 28$$

5. The average of the first five multiples of 7 is
- (a) 20 (b) 21
(c) 28 (d) 30

Ans. (b)

First five multiples of seven are

$$7, 14, 21, 28, 35$$

\therefore average of first five multiples of 7

$$= \frac{7(1+2+3+4+5)}{5} = 21$$

6. The average age of a family of 6 members is 22 years. If the age of the youngest member be 7 years, what was the average age of the family at the birth of the youngest member?
- (a) 15 (b) 18
(c) 21 (d) 12

Ans. (b)

Present sum of ages of family member

$$= 6 \times 22 = 132 \text{ years}$$

sum of ages of family member, 7 years ago

$$= 132 - 6 \times 7 = 90 \text{ years}$$

average age of the family, at the birth of youngest member

$$= \frac{90}{5} = 18 \text{ years}$$

7. The average age of 8 persons in a committee is increased by 2 years when two men aged 35 years and 45 years are substituted by two women. Find the average age of the two women.
- (a) 48 (b) 45
(c) 51 (d) 42

Ans. (a)

Let the average age of 8 persons in the committee be x years

Let the sum of ages of two women be y years.

Then sum of ages of 6 persons excluding two men aged 35 and 45 years

$$= 8x - (35 + 45) = 8x - 80$$

$$\text{Again, } x + 2 = \frac{8x - 80 + y}{8}$$

$$\Rightarrow 8x + 16 = 8x - 80 + y$$

$$\Rightarrow y = 96$$

\therefore average age of two women

$$= \frac{96}{2} = 48 \text{ years}$$

8. The speed of the train in going from Nagpur to Allahabad is 100 km/hr while when coming back from Allahabad to Nagpur, its speed is 150 km/hr. Find the average speed during the whole journey.

- (a) 125 (b) 75
(c) 135 (d) 120

Ans. (d)

Let the distance between Allahabad and Nagpur be x km.

$$\text{The average speed} = \frac{2x}{\frac{x}{100} + \frac{x}{150}}$$

$$= \frac{2 \times 100 \times 150}{250} = 120 \text{ km/hr.}$$

9. The average weight of a class of 29 students is 40 kg. If the weight of the teacher be included, the average rises by 500 gm. What is the weight of the teacher?

- (a) 40.5kg (b) 50.5kg
(c) 45 kg (d) 55 kg

Ans. (d)

Sum of weight of 29 students

$$= 40 \times 29 = 1160 \text{ kg}$$

Let the weight of the teacher be x kg, then

$$40 + 0.5 = \frac{1160 + x}{30}$$

$$\Rightarrow x = 40.5 \times 30 - 1160 = 1215 - 1160$$

10. The average of 3 numbers is 17 and that of the first two is 16. Find the third number.

- (a) 15 (b) 16
(c) 16 (d) 19

Ans. (d)

Sum of 3 number = $3 \times 17 = 51$

sum of the first two members = $2 \times 16 = 32$

\therefore The third member = $51 - 32 = 19$

11. The age of Mitali and Pooja is in the ratio 2 : 6. After 5 years, the ratio of their ages will become 6 : 8. Find the average of their ages after 10 years.

- (a) 12 (b) 13
(c) 17 (d) 24

Ans. (a)

Let the present age of Mitali and Pooja be $2x$ and $6x$ years respectively.

$$\text{After 5 years, } \frac{2x+5}{6x+5} = \frac{6}{8}$$

$$\Rightarrow 16x + 40 = 36x + 30$$

$$\Rightarrow 20x = 10$$

$$\therefore x = \frac{1}{2}$$

Hence Present ages are 1 and 3 years

After ten years, their ages will be 11 and 13 years.

\therefore Average of their ages

$$= \frac{11+13}{2} = 12 \text{ years}$$

12. Find the average of the first 97 natural numbers.

- (a) 47 (b) 37
(c) 48 (d) 49

Ans. (d)

Sum of the first 97 natural members

$$= \frac{97(97+1)}{2} = 4753$$

$$\therefore \text{Their average} = \frac{4753}{97} = 49$$

13. Find the average of all prime numbers between 30 and 50.

- (a) 39.8 (b) 38.8
(c) 37.8 (d) 41.8

Ans. (a)

The prime number between 30 and 50 are 31, 37, 41, 43, 47

\therefore Their average

$$= \frac{31+37+41+43+47}{5} = 39.8$$

14. The average of 5 consecutive number is n. If the next two numbers are also included, the average will.

- (a) increase by 1 (b) remain the same
(c) increase by 1.4 (d) increase by 2

Ans. (a)

Let the five consecutive numbers of $x, x+1, x+2, x+3, \text{ and } x+4$.

$$\text{Given, } n = \frac{x+x+1+x+2+x+3+x+4}{5}$$

$$\Rightarrow n = x+2$$

The average after including the next two numbers

$$= \frac{x+x+1+x+2+x+3+x+4+x+5+x+6}{7}$$

$$= x+3 = n-2+3$$

$$= n+1$$

Hence the average increases by 1.

15. The average of 50 number is 38. If two numbers, namely, 45 and 55 are discarded, the average of the remaining numbers is

- (a) 36.5 (b) 37
(c) 37.6 (d) 37.5

Ans. (d)

Sum of 50 numbers

$$= 38 \times 50 = 1900$$

Sum of remaining numbers

$$= 1900 - (45+55) = 1800$$

average of remaining numbers

$$= \frac{1800}{48} = 37.5$$

16. Average marks obtained by a student in 3 papers is 52 and in the fourth paper he obtains 60 marks. Find his new average.

- (a) 54 (b) 52
(c) 55 (d) 53.5

Ans. (a)

$$\text{The new average} = \frac{3 \times 52 + 60}{4} = 54$$

17. The average weight of 5 men is decreased by 3kg when one of them weighing 150 kg is replaced by another person. Find the weight of the new person?

- (a) 165 (b) 135
(c) 138 (d) 162

Ans. (b)

Let the average weight of 5 men be x kg before replacement of one person.

Also, Let the weight of new person be y kg.

$$\text{Then, } x-3 = \frac{5x-150+y}{5}$$

$$\Rightarrow 5x-15 = 5x-150+y$$

$$\Rightarrow y = 135 \text{ kg}$$

18. The average age of a group of men is increased by 5 years when a person aged 18 years is replaced by a new person of age 38 years. How many men are there in the group?

- (a) 3 (b) 4
(c) 5 (d) 6

Ans. (b)

Let there be n men in the group and the average age of the group be x years before replacement.

$$\text{Then, } x + 5 = \frac{nx - 18 + 38}{n}$$

$$\Rightarrow nx + 5n = nx + 20$$

$$\Rightarrow n = 4$$

19. The average age of the Indian cricket team playing the Nagpur test is 30. The average age of 5 of the players is 27 and that of another set of 5 players, totally different from the first five, is 29. If it is the captain who was not included in either of these two groups, then find the age of the captain.

- (a) 75
(b) 55
(c) 50
(d) Cannot be determined

Ans. (c)

Let the age of the captain be x years

$$\text{Then, } 30 = \frac{27 \times 5 + x + 29 \times 5}{11}$$

$$\Rightarrow 330 = 135 + x + 145$$

$$\therefore x = 330 - 280 = 50 \text{ years}$$

20. A bus goes to Ranchi from Patna at the rate of 60 km per hour. Another bus leaves Ranchi for Patna at the same time as the first bus at the rate of 70 km per hour. Find the average speed for the journeys of the two buses combined if it is known that the distance from Ranchi to Patna is 420 kilometers.

- (a) 64.615 kmph (b) 64.5 kmph
(c) 63.823 kmph (d) 64.82 kmph

Ans. (a)

The average speed

$$= \frac{2 \times 420}{\frac{420}{60} + \frac{420}{70}} = \frac{2 \times 60 \times 70}{130} = \frac{840}{13}$$

$$= 64.615 \text{ kmph}$$

21. Out of three numbers, the first is twice the second and three times the third. The average

of the three numbers is 88. The smallest number is

- (a) 72 (b) 36
(c) 42 (d) 48

Ans. (d)

Let the first number be n . then the other two

numbers will be $\frac{n}{2}$ and $\frac{n}{3}$

$$\text{Again, } 88 = \frac{n + \frac{n}{2} + \frac{n}{3}}{3}$$

$$\Rightarrow 88 = \frac{n}{3} \left(1 + \frac{1}{2} + \frac{1}{3} \right)$$

$$\Rightarrow 88 = \frac{n}{3} \times \frac{11}{6}$$

$$\therefore \text{The smallest number} = \frac{n}{3} = \frac{144}{3} = 48$$

22. The average weight of 6 persons is increased by 2.5 kg when one of them whose weight is 50 kg is replaced by a new man. the weight of the new man is

- (a) 65 kg (b) 75 kg
(c) 76 kg (d) 60 kg

Ans. (a)

Let the average wt. be x kg before replacement

Let the wt. of new man be y kg.

$$\text{Then, } x + 2.5 = \frac{6x - 50 + y}{6}$$

$$\Rightarrow 6x + 15 = 6x - 50 + y$$

$$\Rightarrow y = 65$$

23. The average age of three boys is 15 years. If their ages are in the ratio 3 : 5 : 7, the age of the youngest boy is

- (a) 21 years (b) 18 years
(c) 15 years (d) 9 years

Ans. (d)

Let the ages be $3x$, $5x$ and $7x$ years

$$\text{Then, } 15 = \frac{3x + 5x + 7x}{3}$$

$$\Rightarrow 15 = 5x, \quad \therefore x = 3$$

the age of youngest boy = $3 \times 3 = 9$ years

24. If a , b , c , d and e are five consecutive odd numbers, then their average is
 (a) $5(a+b)$ (b) $(abcde)/5$
 (c) $5(a+b+c+d+d+e)$ (d) None of these

Ans. (d)

Average =

$$\frac{a + (a+2) + (a+4) + (a+6) + (a+8)}{5}$$

$$= \frac{5a+20}{5} = a+4 = c$$

25. The average of first five multiples of 3 is
 (a) 3 (b) 9
 (c) 12 (d) 15

Ans. (b)

$$\text{Average} = \frac{3(1+2+3+4+5)}{5} = \frac{3 \times 15}{5} = 9$$

26. The average weight of a class of 30 students is 40 kg. If, however, the weight of the teacher is included, the average become 41 kg. The weight of the teacher is
 (a) 31 kg (b) 62 kg
 (c) 71 kg (d) 70 kg

Ans. (c)

Let the wt. of teacher be x kg.

$$\text{Then, } 41 = \frac{40 \times 30 + x}{31}$$

$$\Rightarrow x = 41 \times 31 - 1200$$

$$= 1271 - 1200 = 71 \text{ kg}$$

27. The average weight of a school of 40 teachers is 80 kg. If, however, the weight of the principle be included, the average decreases by 1 kg. What is the weight of the principle?
 (a) 109 kg (d) 29 kg
 (c) 39 kg (d) None of these

Ans. (c)

Let the weight of principle be x kg

$$\text{Then, } 79 = \frac{40 \times 80 + x}{41}$$

$$\Rightarrow x = 79 \times 41 - 3200$$

$$= 3239 - 3200 = 39 \text{ kg}$$

28. The average temperature of 1st, 2nd 3rd December was 24.4°C . The average temperature of the first two days was 24°C . The temperature on the 3rd of December was
 (a) 20°C (b) 25°C
 (c) 25.2°C (d) None of these

Ans. (c)

Let the temp. on 3rd of December be x C.

$$\text{Then } 24.4 = \frac{2 \times 24 + x}{3} = 25.2^\circ\text{C}$$

29. The average of 20 results is 30 and that of 30 more results is 20. For all the results taken together, the average is
 (a) 25 (b) 50
 (c) 12 (d) 24

Ans. (d)

The required average

$$= \frac{20 \times 30 + 30 \times 20}{50} = \frac{1200}{50} = 24$$

30. The average temperature on Monday, Tuesday and Wednesday was 41°C and on Tuesday, Wednesday and Thursday it was 40°C . If on Thursday it was exactly 39°C , then on Monday, the temperature was
 (a) 42°C (b) 46°C
 (c) 23°C (d) 26°C

Ans. (a)

The sum of temp. on Tuesday and Wednesday
 $= 3 \times 40 - 39 = 81^\circ\text{C}$

The sum of temp. on Monday, Tuesday, and Wednesday = $3 \times 41 - 81 = 42^\circ\text{C}$

□□□□

Average



Practice Exercise: I

1. The daily earnings of a taxi driver during a week are : Rs. 60, Rs. 65, Rs. 70, Rs. 52.50, Rs. 63, Rs. 73 and Rs. 68. What is his average daily earning for the week?
 - (a) Rs 74.50
 - (b) Rs 54.50
 - (c) Rs 64.50
 - (d) Rs 84.50
2. The average of 10 numbers is 7. What will be the new average if each of the numbers is multiplied by 8?
 - (a) 45
 - (b) 52
 - (c) 56
 - (d) 55
3. There are 35 students in a hostel. If the number of students increased by 7, the expenses of the mess were increased by Rs. 42 per day while the average expenditure per head diminished by Rs. 1. Find the original expenditure of the mess.
 - (a) Rs. 480
 - (b) Rs. 440
 - (c) Rs. 520
 - (d) Rs. 420
4. An aeroplane travels distances 2500 km, 1200 km and 500 km at the rate of 500 km/hr, 400 km, and 250km/hr, respectively. The average is
 - (a) 420 km/hr
 - (b) 410 km/hr
 - (c) 405 km/hr
 - (d) 575 km/hr
5. The average weight of 24 students of section A of a class is 58 kg whereas the average weight of 26 students of section B of the same class is 60.5 kg. Find the average weight of all the 50 students of the class.
 - (a) 57.4 Kg.
 - (b) 59.3 kg
 - (c) 58.9 kg
 - (d) 59.7 kg
6. The average age of 5 members is 21 years. If the age of the youngest member be 5 years, find the average age of the family at the birth of the youngest member.
 - (a) 24 years
 - (b) 25 years
 - (c) 20 years
 - (d) 28 years
7. The average monthly salary of a staff of 9 persons is Rs. 2450. One member of the staff whose monthly salary is Rs. 2650 is transferred. Find the average salary of the remaining 8 persons of the staff.
 - (a) Rs. 2425
 - (b) Rs. 2625
 - (c) Rs. 3025
 - (d) Rs. 2825
8. The average of five consecutive even numbers starting with 4, is
 - (a) 6
 - (b) 7
 - (c) 8
 - (d) 7.5
9. 3 years ago the average age of a family of 5 members was 17 years. With the birth of a new baby the average remains the same even today. Find the age of the baby.
 - (a) 1 years
 - (b) 3 years
 - (c) $2\frac{1}{2}$ years
 - (d) 2 years
10. The average of 17 numbers is 10.9. If the average of first nine number is 10.5 and that the last nine number is 11.4, the middle no. is
 - (a) 11.8
 - (b) 11.4
 - (c) 10.9
 - (d) 11.7
11. A batsmen in his 17th innings makes a score of 85, and thereby increases his average by 3. What is his average after the 17th innings? He had never been 'not out'.
 - (a) 47
 - (b) 37
 - (c) 39
 - (d) 43
12. The sum of three numbers is 98. If the ratio between first and second be 2 : 3 and that between second and third be 5 : 8, then the second number is
 - (a) 30
 - (b) 20
 - (c) 58
 - (d) 48

13. A number x equals 80% of the average of 5, 7, 14 and a number y . If the average of x and y is 26, the value of x is
- (a) 13 (b) 26
(c) 39 (d) None of these
14. It rained as much on Wednesday as on all the other days of the week combined. If the average rainfall for the whole week was 3 cm, how much did it rain on Wednesday?
- (a) 2.625 cm (b) 3 cm
(c) 10.5 cm (d) 15 cm
15. The average age of 8 men is increased by 2 years. When two of them, whose ages are 20 years and 24 years respectively, are replaced by two women. What is the average age of these women?
- (a) 36 years (b) 30 years
(c) 40 years (d) 42 years
16. The average speed of a train running at a speed of 30 km/hr during the first 100 kilometers, at 40 km/hr during the second 100 kilometers and at 50 km/hr during the last 100 kilometers is nearly
- (a) 38.5 km/hr (b) 38.3 km/hr
(c) 40.0 km/hr (d) 39.2 km/hr
17. The average weight of 3 men A, B and C is 84 kg. Another man D joins the group and the average now becomes 80 kg. If another man E, whose weight is 3 kg more than that of D, replaces A, then average weight of B, C, D and E becomes 79 kg. The weight of A is
- (a) 70 kg (b) 72 kg
(c) 75 kg (d) 80 kg
18. Of the three numbers the first is twice the second and the second is thrice the third. If the average of the three numbers is 10 the numbers are
- (a) 18, 3, 9 (b) 9, 3, 18
(c) 3, 9, 18 (d) 18, 9, 3
19. The average weight of 36 students is 50 kg. It was found later that the figure of 37 kg was misread as 73 kg. What is the correct average?
- (a) 49 kg (b) 51 kg
(c) 50.5 kg (d) None of these
20. The average of marks obtained by 120 candidates was 35. If the average of marks of passed candidates was 39 and that of failed candidates was 15, the number of candidates who passed the examination is
- (a) 100 (b) 110
(c) 120 (d) 150
21. In a class, there are 20 boys whose average age is decreased by 2 months, when one boy aged 18 years is replaced by a new boy. The age of the new boy is
- (a) 14 yrs. 8 months
(b) 15 years
(c) 16 yrs 4 months
(d) 17 yrs. 10 months
22. The average of two numbers is 62. If 2 is added to the smaller number, the ratio between the numbers becomes 1 : 2. The smaller number is
- (a) 60 (b) 30
(c) 84 (d) 40
23. The average daily wages of A, B and C is Rs. 120. If B earns Rs. 40 more than C per day and A earns double of what C earns per day, the wages of A per day is
- (a) Rs. 80 (b) Rs. 120
(c) Rs. 160 (d) Rs. 100
24. With an average speed of 40 km/hr a train reaches its destination on time. If it goes with an average speed of 35 km/hr, it is late by 15 minutes. The total journey is
- (a) 30 km (b) 40 km
(c) 70 km (d) 80 km

25. In a competitive examination, the average marks obtained was 45. It was later discovered that there was some error in computerisation and the marks of 90 candidates had to be changed from 80 to 50 and the average came down to 40 marks. The total no. of candidates who appeared in examination is
 (a) 520 (b) 550
 (c) 540 (d) 525
26. A man whose bowling average is 12.4 takes 5 wickets for 26 runs and thereby decreases his average by 0.4. The number of wickets, taken by him before his last match is
 (a) 85 (b) 78
 (c) 72 (d) 64
27. There were 35 students in a hostel. If the number of students increase by 7, the expenses of the mess increase by Rs. 42 per day while the average expenditure per head diminishes by Rs. 1. Find the original expenditure of the mess.
 (a) Rs 480 (b) Rs. 420
 (c) Rs 520 (d) Rs. 460
28. The average of these consecutive numbers is n . If the next two consecutive numbers are also included, the average of the five numbers will
 (a) remain the same
 (b) increase by 0.5
 (c) increase by 1
 (d) increase by 1.5
29. On the three numbers, second is twice the first and is also thrice the third. If the average of the three numbers is 44, the largest number is
 (a) 24 (b) 36
 (c) 72 (d) 108
30. The average age of a committee of 8 members is 40 years. A member, aged 55 years, retired and he was replaced by a member aged 39 years. The average age of the present committee is
 (a) 39 years (b) 38 years
 (c) 36 years (d) 35 years

Solutions

1. Ans. (c)

Total earning for 7 days

$$= \text{Rs } (60 + 65 + 70 + 52.50 + 63 + 73 + 68)$$

$$= \text{Rs } 451.50$$

Average daily earning

$$= \text{Rs. } \frac{451.50}{7} = \text{Rs. } 64.50$$

2. Ans. (c)

The average of 10 number = 7

$$\text{Total of 10 numbers} = 10 \times 7 = 70$$

New total of 10 numbers after each given

$$\text{numbers is multiplied by 8} = 70 \times 8 = 560$$

$$\therefore \text{New average} = \frac{560}{10} = 56.$$

3. Ans. (d)

Let the original expenditure = Rs x

$$\text{Original average expenditure} = \frac{x}{35}$$

$$\text{New average expenditure} = \frac{x+42}{42}$$

$$\Rightarrow \frac{x}{35} - \frac{x+42}{42} = 1 \Rightarrow x = 420$$

$$\therefore \text{Original expenditure} = \text{Rs } 420$$

4. Ans. (a)

The total time taken can be calculated as shown below :

Distance	Speed	Time
25 km	500 km/hr	5 hrs.
1200 km	400 km/hr	3hrs.
500 km	250 km/hr	2hrs.
Total 4200 km		10hrs.

$$\text{Average speed} = \frac{4200}{10} = 420 \text{ km/hr.}$$

5. Ans. (b)

Average weight of 24 students of section

$$A = 58 \text{ kg}$$

Total weight of 24 students of section

$$A = 58 \times 24 = 1392 \text{ kg}$$

Average weight of 26 students of section

$$B = 60.5 \text{ kg}$$

Total weight of 50 student = (1392 + 1573) kg

$$= 2965 \text{ kg}$$

Average weight of students of students in the class

$$= \frac{2965}{50} = 59.3 \text{ kg.}$$

6. Ans. (c)

Total age of 5 members

$$= 21 \times 5 = 105 \text{ year}$$

Total age of 4 members at the birth of the younger member, that is, 5 years ago

$$= 105 - (5 \times 5) = 80 \text{ years}$$

Before the birth of the youngest member, the family consisted of only 4 members.

Average age of 4 members 5 years ago

$$= \frac{80}{4} = 20 \text{ years.}$$

7. Ans. (a)

Average salary of 9 persons = Rs. 2450

Total salary of 9 persons

$$= \text{Rs. } 2450 \times 9 = \text{Rs. } 22050$$

Total salary of the person who is transferred

$$= \text{Rs. } 2650$$

Thus, the total salary of remaining 8 persons

$$= \text{Rs. } 22050 - 2650 = \text{Rs. } 19400$$

The average salary of the remaining 8 persons

$$= \text{Rs. } \frac{19400}{8} = \text{Rs. } 2425.$$

8. Ans. (c)

The five even consecutive numbers are 4, 6, 8, 10 and 12

Their average

$$= \frac{4+6+8+10+12}{5} = \frac{40}{5} = 8.$$

9. Ans. (d)

Present age of 5 members

$$= (5 \times 17 + 3 \times 5) \text{ years.}$$

$$= 100 \text{ years.}$$

Present age of 5 members and a baby

$$= 17 \times 6 = 102 \text{ yrs.}$$

$$\therefore \text{Age of the baby} = (102 - 100) \text{ yrs} = 2 \text{ years.}$$

10. Ans. (a)

Sum of first nine numbers + sum of last nine number = $10.5 \times 9 - 11.4 \times 9$

$$= 21.9 \times 9 = 197.1$$

Hence, the middle number

$$= 197.1 - 17 \times 10.9$$

$$= 197.1 - 185.3 = 11.8.$$

11. Ans. (b)

Average score before 17th innings

$$= 85 - 3 \times 17 = 34$$

\therefore Average score after 17th innings

$$= 34 + 3 = 37.$$

12. Ans. (a)

Let the number be x, y and z. Then,

$$x + y + z = 98, \frac{x}{y} = \frac{2}{3} \text{ and } \frac{y}{z} = \frac{5}{8}$$

$$\therefore x = \frac{2y}{3} \text{ and } z = \frac{8y}{5}$$

$$\text{So } \frac{2y}{3} + y + \frac{8y}{5} = 98$$

$$\text{or, } \frac{49y}{15} = 98 \text{ or, } y = 30.$$

13. Ans. (c)

$$\text{Average of } 5, 7, 14 \text{ and } y = \frac{5+7+14+y}{4}$$

Therefore, $x = 80\%$ of

$$\frac{5+7+14+y}{4} = \frac{80}{100} \times \frac{26+y}{4}$$

$$\Rightarrow x = \frac{26+y}{5} \quad \dots(i)$$

$$\text{Also } \frac{x+y}{2} = 26 \quad \dots(ii)$$

From (i) and (ii), we get

$$52 - y = \frac{26+y}{5} \Rightarrow y = 39.$$

14. Ans. (c)

Let the rainfall on Wednesday be x cm so that on the other 6 days, the total is also x .

Since average rainfall for the week = 3cm.

$$\therefore x + x = 3 \times 7 \text{ or, } x = 10.5 \text{ cm.}$$

15. Ans. (b)

Let the average age of 8 men be x years

$$\therefore \text{Sum of the ages of 8 men} = 8x \text{ years}$$

Now, according to the condition of the question, average age of (6 men + 2 women)

$$= (x + 2) \text{ years}$$

$$\therefore \text{Sum of the ages of (6 men + 2 women)}$$

$$= 8(x + 2) = 8x + 16 \text{ years}$$

Hence, it is clear that on replacing two men by two women, sum of their ages increased by 16 years

Therefore, sum of the ages of two women

$$= (20 + 24) + 16 = 60 \text{ yrs}$$

$$\therefore \text{Average age of the women } \frac{60}{2} = 30 \text{ yrs}$$

16. Ans. (b)

Time taken to cover first 100 kilometres

$$= \frac{100}{30} = 3\frac{1}{3} \text{ hrs}$$

Time taken to cover second 100 kilometres

$$= \frac{100}{40} = 2\frac{1}{2} \text{ hrs}$$

Time taken to cover last 100 kilometres

$$= \frac{100}{5} = 2 \text{ hrs}$$

Total time taken

$$3\frac{1}{3} + 2\frac{1}{2} + 2 = \frac{10}{3} + \frac{5}{2} + 2 = \frac{47}{6} \text{ hrs.}$$

Total distance covered = 300 km

$$\therefore \text{Average speed} = \frac{300}{47/6}$$

$$= \frac{300 \times 6}{47} = 38.3 \text{ km/hr}$$

17. Ans. (c)

$$\text{Weight of D} = (80 \times 4 - 84 \times 3) \text{ kg} = 68 \text{ kg}$$

$$\text{Weight of E} = (68 + 3) \text{ kg} = 71 \text{ kg}$$

(B + C + D + E)'s

$$\text{Weight} = (79 \times 4) \text{ kg} = 316 \text{ kg}$$

$$\therefore \text{(B+C)'s weight} = [316 - (68 + 71)] \text{ kg}$$

$$= 177 \text{ kg}$$

$$\text{Hence, A's weight} = [(84 \times 3) - 177] \text{ kg} = 75 \text{ kg}$$

18. Ans. (d)

go by option

19. Ans. (a)

Correct average

$$= \frac{50 \times 36 - 73 + 37}{36} = \frac{1764}{36} = 49 \text{ kg}$$

20. Ans. (a)

Let the number of candidates who passed = x .

$$\text{Then, } 39 \times x + 15 \times (120 - x) = 120 \times 35$$

$$\therefore 24x = 4200 - 1800$$

$$\text{or, } x = \frac{2400}{24}, x = 100.$$

21. Ans. (a)

Total decrease = (20×2) months
 = 3 years 4 months
 \therefore Age of the new boy = 18 years - 3 years
 4 months
 = 14 years 8 months.

$$\therefore 40 = \frac{45x - 2700}{x}$$

$$\text{or, } 40x = 45x - 2700$$

$$\Rightarrow 5x = 2700 \text{ or, } x = 540$$

22. Ans. (d)

Let the numbers be x and y , $x < y$
 Then, $x + y = 124$;

$$\frac{x+2}{y} = \frac{1}{2} \Rightarrow y = 2x + 4.$$

Solving above equations, we get
 $y = 84$, $x = 40$.

23. Ans. (c)

Let daily wages of C = x
 Then, daily wages of A = $2x$
 and, daily wages of B = $x + 40$
 Hence, average daily wages of A, B and C

$$= \frac{x + 2x + x + 40}{3} = \frac{4x + 40}{3}$$

$$\therefore \frac{4x + 40}{3} = 120 \text{ or, } 4x + 40 = 360$$

$$\Rightarrow 4x = 320 \text{ or, } x = 80$$

$$\therefore \text{Wages of A per day} = 2 \times 80 = \text{Rs } 160.$$

24. Ans. (c)

$$\frac{x}{35} - \frac{x}{40} = \frac{15}{60} \text{ or, } \frac{5x}{35 \times 40} = \frac{1}{4}$$

$$\text{or, } x = \frac{35 \times 40}{5 \times 4} = 70$$

25. Ans. (c)

Let the number of candidates be x , Then, total marks obtained by all the candidates = $45x$

Marks reduced for 90 candidates
 = $30 \times 90 = 2700$

Total reduced marks = $45x - 2700$

$$\text{Reduced average} = \frac{45x - 2700}{x}$$

26. Ans. (a)

Let the number of wickets taken before the last match = x

$$\text{Then, } \frac{12.4x + 26}{x + 5} = 12 \Rightarrow x = 85$$

27. Ans. (b)

Suppose the average expenditure was Rs. x , Then, total expenditure = $35x$

When 7 more students join the mess, total expenditure = $35x + 42$

Now, the average expenditure

$$= \frac{35x + 42}{35 + 7} = \frac{35x + 42}{42}$$

$$\text{Now, we have } \frac{35x + 42}{42} = x - 1$$

$$\therefore x = 12$$

Thus, the original expenditure of the mess

$$35 \times 12 = \text{Rs. } 420$$

28. Ans. (c)

Let the number be $n - 1$, n and $n + 1$.

Their average = n

Next two consecutive numbers are $n + 2$ and $n + 3$

Therefore, the average of five numbers

$$= \frac{(n-1) + n + (n+1) + (n+2) + (n+3)}{5}$$

$$= \frac{5n + 5}{5} = n + 1.$$

29. Ans. (c)

Let the number be x , $2x$, $\frac{2}{3}x$

$$\text{Average} = \frac{x + 2x + \frac{2}{3}x}{3} \Rightarrow \frac{11x}{9} = 44$$

$$\therefore x = \frac{44 \times 9}{11} = 36$$

So, the numbers are 36, 72 and 24

Hence, the largest one is 72.

30. Ans. (b)

New average of the committee (in years)

$$= \frac{8 \times 40 - 55 + 39}{8} = \frac{320 - 16}{8} = \frac{304}{8}$$

= 38 years.

□□□□



Ratio & Proportion

Ratio

A ratio is a comparison of two quantities by division. It is a relation that one quantity bears to another with respect to magnitude. In other words, ratio means what part one quantity is of another. The quantity may be same kind or different kinds.

If a and b are two numbers, then the ratio of a to b is a/b or $a : b$ and is denoted by $a : b$. The two quantities that are being compared are called terms. The first is called antecedent and second term is called consequent.

For Example, the ratio 5 : 8 represent $\frac{5}{8}$ with antecedent 5 and consequent 8.

Note:

1. A ratio is a number, so to find the ratio of two quantities, they must be expressed in the same units.
2. A ratio does not change if both of its terms are multiplied or divided by the same

number. Thus, $\frac{3}{4} = \frac{6}{8} = \frac{12}{16}$ etc

Type of Ratios

1. **Duplicate Ratio:** The ratio of squares of two number is called the duplicate ratio of the two numbers.

For example

$\frac{2^2}{5^2} = \frac{4}{25}$ is called the duplicate ratio of $\frac{2}{5}$.

2. **Triplicate Ratio:** The ratio of the cubes of two number is called the triplicate ratio of the two numbers.

For examples,

$\frac{2^3}{5^3}$ or $\frac{8}{125}$ is triplicate ratio of $\frac{2}{5}$.

3. **Sub-duplicate Ratio:** The ratio of the square root of two number is called the sub-duplicate ratio of two numbers for example.

$\frac{2}{5}$ is sub-duplicate ratio of $\frac{4}{25}$.

4. **Sub-triplicate Ratio:** The ratio of the cube roots of two numbers is called the sub-triplicate ratio of two numbers.

For example

$\frac{3}{4}$ is sub-triplicate ratio of $\frac{27}{64}$.

5. **Inverse Ratio or Reciprocal Ratio:** If the antecedent and consequent of a ratio interchange their places, the new ratio is called the inverse ratio of the first.

Thus, if $a : b$ be the given ratio, then

$\frac{1}{a} : \frac{1}{b}$ or $b : a$ is its inverse ratio.

For example,

$\frac{4}{3}$ is the inverse ratio of $\frac{3}{4}$.

6. **Compound Ratio:** The ratio of the product of the antecedent to that of the consequent of two or more given ratio is called the compound ratio. Thus if $a : b$ and $c : d$ are two given ratios, then $ac : bd$ is the compound ratio of the given ratios.

For example if $\frac{1}{2} : \frac{3}{4} : \frac{5}{7}$ be the given ratios,

then their compound ratio is $\frac{1 \times 3 \times 5}{2 \times 4 \times 7} = \frac{15}{56}$

Proportion

The equality of two ratios is called proportion if

$\frac{a}{b} = \frac{c}{d}$, then a, b, c and d are said to be in

proportion and we write

$$a : b :: c : d$$

This is read as "a is to b as c is to d"

For examples, since $\frac{3}{5} = \frac{15}{25}$, we write

$3 : 5 :: 15 : 25$ and say 3, 5, 15, 25 are in proportion.

Each term of the ratio $\frac{a}{b}$ and $\frac{c}{d}$ is called a proportion. a, b, c and d are respectively the first, second, third and fourth proportional. Here a, d are known as extreme s and b, c are known as means.

Some Basic Formulae

1. If four quantities are in proportion, then product of means = Product of Extremes for example, in proportion $a : b :: c : d$, we have $b \times c = a \times d$

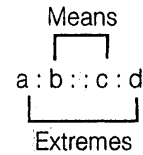

From this relation we see that if any three of the four quantities are given, the fourth can be determined.

2. **Fourth Proportional**

If $a : b :: c : x$, x is called the fourth proportional of a, b, c .

We have, $\frac{a}{b} = \frac{c}{x}$ or, $x = \frac{b \times c}{a}$

Thus, fourth proportional of a, b, c , is $\frac{b \times c}{a}$

Example: Find the fourth proportional to the numbers 3, 8, 6

Solution: Let, x be the fourth proportional, then

$$3 : 8 :: 6 : x \text{ or } \frac{3}{8} = \frac{6}{x}$$

$$\therefore x = \frac{6 \times 8}{3} = 16.$$

3. **Third Proportional**

If $a : b :: b : x$ is called the third proportional of a, b

We have $\frac{a}{b} = \frac{b}{x}$ or $x = \frac{b^2}{a}$

Thus, third proportional of a, b is $\frac{b^2}{a}$.

Example: Find a third proportional to the numbers 3, 6

Solution: If third proportional is x then

$$3 : 6 :: 6 : x$$

$$\text{So } x = \frac{6 \times 6}{3} = 12$$

4. Mean Proportional

If $a : x :: x : b$, x is called the mean or second proportional of a , b .

We have, $\frac{a}{x} = \frac{x}{b}$ or $x^2 = ab$

$$x = \sqrt{ab}$$

\therefore Mean proportional of a and b is \sqrt{ab}

We also say that a , x , b are in continued proportion

Example: Find the mean proportional between 4 and 64.

Solution: Let x be the mean proportional. Then $4 : x :: x : 64$ or

$$\frac{4}{x} = \frac{x}{64} \text{ or } x^2 = 4 \times 64, x = 16$$

5. If $\frac{a}{b} = \frac{c}{d}$ then

$$(i) \frac{a+b}{b} = \frac{c+d}{d} \text{ (Componendo)}$$

$$(ii) \frac{a-b}{b} = \frac{c-d}{d} \text{ (Dividendo)}$$

$$(iii) \frac{a+b}{a-b} = \frac{c+d}{c-d}$$

(Componendo and Dividendo)

$$(iv) \frac{a}{b} = \frac{a+c}{b+d} = \frac{a-c}{b-d}$$

Example: The sum of two number is c and their quotient is P/Q . Find the number.

Solution: let the number be x , y

$$\text{Given } x + y = c \quad \dots(i)$$

$$\text{and } \frac{x}{y} = \frac{p}{q} \quad \dots(ii)$$

$$\text{So, } \frac{x}{x+y} = \frac{p}{p+q} = \frac{x}{c} = \frac{p}{p+q} \text{ (using (i))}$$

$$\Rightarrow x = \frac{pc}{p+c}$$

□□□□

Partnership

To run a business or any organisation, we need to have partnerships. There are two types of partners.

- Working Partner:** Those partners who invest the money and manage the business or affairs of organisation are called working partners.
- Sleeping Partners:** Those partners who merely invest money and do not involve in business affairs are called sleeping partners.

Mainly there are four types of conditions related to distribution of profit in business.

Condition I:

When time period of investment is constant then profit of partners will be divided into ratio

$$m_1 : m_2, m_3 \dots : m_n, \text{ where}$$

$m_1, m_2, m_3 \dots m_n$ are investment of respective partners.

Ex.1 What will be ratio of profit if three partners A, B and C are investing 20000, 45000 and Rs. 60000 for one year.

Sol.: Ratio of profits of A, B and C will be

$$20000 : 45000 : 60000$$

$$\Rightarrow 4 : 9 : 12 \text{ Ans.}$$

Condition II:

When amount invested is same for different partners but time period is different

then profit will be divided into ratio of their time invested i.e.

$$t_1 : t_2 : t_3 \dots : t_n$$

Ex. 2 If three partners A, B and C are investing Rs. 20000 each for period of 1 year, 2 years and 3 years respectively then find the ratio of their profits.

Sol.: Ratio of their profits will be

$$t_1 : t_2 : t_3 \text{ i.e.} \\ \Rightarrow 1 : 2 : 3 \text{ Ans.}$$

Condition III:

When amount of investment and time period both are different for different partners, then profit will be divided into following ratio.

$$m_1 t_1 : m_2 t_2 : m_3 t_3 \dots : m_n t_n$$

where m_1, m_2, \dots, m_n are the respective amounts and t_1, t_2, \dots, t_n are the respective time period of their investment.

Ex.1 Three partners undergo a partnership. Their investments are 30000 Rs. 40000 Rs and 50000 Rs respectively for time periods of 5 years, 2 years and 3 years respectively. Find the ratio of their profits.

Sol.: Ratio of their profit will be

$$m_1 t_1 : m_2 t_2 : m_3 t_3 \\ \Rightarrow 30 \times 5 : 40 \times 2 : 50 \times 3 \\ \Rightarrow 5 : 3 : 12 \text{ Ans.}$$

Condition IV:

Multiple investment for different time period.
In this case profit will be divided into following ratio.

$$\Sigma m_1 t_1 : \Sigma m_2 t_2 : \Sigma m_3 t_3 \dots : \Sigma m_n t_n$$

Ex.1 Three partners undergo a partnership with initial investment of Rs. 120000, Rs. 80000 and Rs. 150000. Next year A and B invested Rs. 80000 and Rs. 20000 respectively whereas C withdraws Rs. 50000 from the business. In third year of their partnership A, B and C invested Rs. 100000, Rs. 50000 and Rs. 100000 respectively.
Find the ratio of their profits.

Sol.:	Investment		
	A	B	C
1 st year	120K	80K	150K
II nd year	+80K	+20K	-50K
III rd year	+100K	+50K	+100K

	Effective Investment		
	A	B	C
1 st year	120K	80K	150K
II nd year	200K	100K	100K
III rd year	300K	150K	200K
	620K	330K	450K

Ratio of their profit will be

$$\Rightarrow 620 : 330 : 450 \Rightarrow 62 : 33 : 45 \text{ Ans.}$$

Ex.2 Three partners X, Y and Z undergo a partnership with initial investment of Rs. 120000, Rs. 50000 and Rs. 150000 respectively. Next year A invested Rs. 50000 more in the business. In the third year B and C invested Rs. 50000 each in the business. They remain in partnership for five years. Find the ratio of their profits at the end of five years.

Sol.:	Investment		
	A	B	C
1 st year	120K	50K	120K
II nd year	+50K	-	-
III rd year	-	+50K	+50K
IV year	-	-	-
V year	-	-	-
	Effective Investment		
	A	B	C
1 st year	120K	50K	150K
II nd year	170K	50K	150K
III rd year	170K	100K	200K
IV year	170K	100K	200K
V year	170K	100K	200K
	800	400	900

Ratio of their profit will be

$$\Rightarrow 800 : 400 : 900 \Rightarrow 8 : 4 : 9 \text{ Ans.}$$



Solved Examples

1. Divide Rs. 500 among A, B, C and D so that A and B together get thrice as much as C and D together, B gets four times of what C gets and C gets 1.5 times as much as D. Now the value of what B gets is
(a) 300 (b) 75
(c) 125 (d) None of these
Ans. (a)
 $A + B + C + D = 500$
Here $A + B = 3(C + D)$
So $4(C + D) = 500$
 $C + D = 125$
 $A + B = 375$
also $B = 4C$ and $C = 1.5D$
 $C + D = 125$
 $2.5D = 125$
 $D = 50, C = 75$
 $\therefore B = 300$
2. If $6x^2 + 6y^2 = 13xy$, what is the ratio of x to y ?
(a) 2 : 3 (b) 3 : 2
(c) 4 : 5 (d) 1 : 2
Ans. (a) and (b) both
 $6x^2 + 6y^2 = 13xy$
Here using options (a) and (b) will satisfy the given condition
 $x : y = 2 : 3$
3. If 4 examiners can examine a certain number of answer books in 8 days by working 5 hours a day, for how many hours a day would 2 examiners have to work in order to examine twice the number of answer books in 20 days.
(a) 6 (b) $7\frac{1}{2}$
(c) 8 (d) 9
Ans. (c)
Man. Day. Hour = constant
 $= 4 \cdot 8 \cdot 5 = 160$

Next \rightarrow Man. day. hour = 160×2 (twice as earlier)

$$2 \cdot 20 \cdot h = 160 \times 2$$

$$h = 8$$

4. In a mixture of 40 litres, the ratio of milk and water is 4 : 1. How much water must be added to this mixture so that the ratio of milk and water becomes 2 : 3.
(a) 20 litres (b) 32 litres
(c) 40 litres (d) 30 litres
Ans. (c)
Let water is x
 $4x : x = \text{milk} : \text{water}$
 $32 : 8 = 4x : x$ (since total 40 litres)
Now $\frac{32}{8+x} = \frac{2}{3}$, $x = 40$ litre
5. If three numbers are in the ratio of 1 : 2 : 3 and half the sum is 18, then the ratio of squares of the numbers is:
(a) 6 : 12 : 13 (b) 1 : 2 : 4
(c) 36 : 144 : 324 (d) None of these
Ans. (c)
Let numbers are
 $x : 2x : 3x$ also it is given that
 $\frac{1}{2}(x + 2x + 3x) = 18$
 $6x = 36, x = 6$
 $6 : 12 : 18$
ratio of squares 36 : 144 : 324; or also 1 : 4 : 9
6. The ratio between two numbers is 3 : 4 and their LCM is 180. The first number is:
(a) 60 (b) 45
(c) 15 (d) 20
Ans. (b)
Let number are $3x$ and $4x$
 $3x \times 4x = \text{HCF} \times 180$
Clearly HCF will be x .
 $12x^2 = x \times 180, x = 15$
numbers will be 45 : 60

7. The incomes of A and B are in the ratio 3 : 2 and their expenditures are in the ratio 5 : 3. If each saves Rs. 1000, then, A's income is

(a) Rs. 3000 (b) Rs. 4000
(c) Rs. 6000 (d) Rs. 9000

Ans. (c)

Let incomes are $3x : 2x$
expenditures are $5y : 3y$
then

$$3x - 5y = 1000 \text{ (1) also}$$

$$2x - 3y = 1000 \text{ (2)}$$

from (1) and (2) we get

$$6x - 10y = 2000$$

$$+ 6x - 9y = 3000$$

$$\Rightarrow -y = -1000$$

$$y = 1000, x = 2000$$

A's income is 6000

8. If the ratio of sines of angles of a triangle is $1 : 1 : \sqrt{2}$, then the ratio of square of the greatest side to sum of the squares of other two sides is

(a) 3 : 4
(b) 2 : 1
(c) 1 : 1
(d) Can't be determined

Ans. (c)

$$\sin A : \sin B : \sin C = 1 : 1 : \sqrt{2}$$

$$\sin A : \sin B = 1 : 1$$

angle are equal

So it is a right angled triangle.

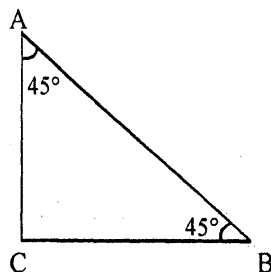

$$\text{the } AB^2 : (AC + CB)^2 = 1 : 1$$

9. Divide Rs. 680 among A, B and C such that A gets $\frac{2}{3}$ of what B gets and B gets $\frac{1}{4}$ th of what C gets. Now the share of C is?

(a) Rs. 480 (b) Rs. 300
(c) Rs. 420 (d) None of these

Ans. (a)

$$680 = A + B + C$$

$$A = \frac{2}{3}B \text{ and } B = \frac{1}{4}C, 4B = C$$

$$A = \frac{2}{3}B, C = 4B$$

$$680 = \frac{2}{3}B + B + 4B$$

$$680 = \frac{17}{3}B, B = 120, C = 480$$

10. The students in three batches at Made Easy are in the ratio 2 : 3 : 5. If 20 students are increased in each batch, the ratio change to 4 : 5 : 7. The total number of students in the three batches before the increase were.

(a) 10 (b) 90
(c) 100 (d) 150

Ans. (c)

Let students are $2x : 3x : 5x$ now

According to the given condition

$$2x + 20 : 3x + 20 : 5x + 20 = 4 : 5 : 7$$

$$x = 10$$

$$20 : 30 : 50 = 2 : 3 : 5 \text{ and after adding } 20$$

$$40 : 50 : 70$$

11. The speeds of three cars are in the ratio 2 : 3 : 4. The ratio between the times taken by these cars to travel the same distance is

(a) 2 : 3 : 4 (b) 4 : 3 : 2
(c) 4 : 3 : 6 (d) 6 : 4 : 3

Ans. (d)

Speeds are in the ratio 2 : 3 : 4

$$\text{ratio of time taken will be } \frac{1}{2} : \frac{1}{3} : \frac{1}{4}$$

$$= \frac{6 : 4 : 3}{12} = 6 : 4 : 3$$

12. After an increment of 7 in both the numerator and denominator, a fraction change to $\frac{3}{4}$. Find the original fraction.

- (a) $\frac{5}{12}$ (b) $\frac{7}{9}$
 (c) $\frac{2}{5}$ (d) $\frac{3}{8}$

Ans. (c)

$$\frac{x+7}{y+7} = \frac{3}{4}$$

$4x + 28 = 3y + 21$, $4x + 7 = 3y$,
 only $x : y = 2/5$ satisfies the given condition.

13. The difference between two positive numbers is 10 and the ratio between them is 5 : 3. Find the product of the two numbers.

- (a) 375 (b) 175
 (c) 275 (d) 125

Ans. (a)

$$x - y = 10 \quad \dots(1)$$

$$x : y = 5 : 3 \quad \dots(2)$$

$$x : y = 5t : 3t \quad \dots(3)$$

according to (1) and (3)

$$5t - 3t = 10$$

$$2t = 10, t = 5$$

$$x = 25, y = 15$$

Product of two numbers = 375

14. The present ratio of ages of A and B is 4 : 5. 18 years ago, this ratio was 11 : 16. Find the sum total of their present ages.

- (a) 90 years (b) 105 years
 (c) 110 years (d) 80 years

Ans. (a)

Let ages are $4x : 5x$ then it is given that

$$\frac{4x-18}{5x-18} = \frac{11}{16}$$

$$64x - 288 = 55x - 198$$

$$9x = 90, x = 10$$

Ages are 40 and 50 sum = 90

15. Four numbers in the ratio 1 : 3 : 4 : 7 add up to give a sum of 105. Find the value of the biggest number.

- (a) 42 (b) 35
 (c) 49 (d) 63

Ans. (c)

$$x : 3x : 4x : 7x$$

are four numbers also

$$x + 3x + 4x + 7x = 105$$

$$15x = 105, x = 7, 7x = 49$$

16. If the ratio of the ages of Maya and Chhaya is 6 : 5 at present and fifteen years from now, the ratio will get changed to 9 : 8, then find Maya's present age.

- (a) 24 years (b) 30 years
 (c) 18 years (d) 33 years

Ans. (b)

Let their ages age $6x : 5x$ then, it is given that

$$\frac{6x+15}{5x+15} = \frac{9}{8}$$

$$48x + 120 = 45x + 135$$

$$3x = 15, x = 5$$

$$6x : 5x = 30 : 25$$

Maya age is 30 years

17. If Rs. 58 is divided among 150 children such that each girl and each boy gets 25 p and 50 p respectively. Then how many girls are there?

- (a) 52 (b) 54
 (c) 68 (d) 62

Ans. (c)

Let the number of girls and boys are x and y then

$$0.25x + 0.5y = 58 \quad \dots(1)$$

also

$$x + y = 150 \quad \dots(2)$$

from (1) and (2) we get

$$0.5x + y = 116$$

$$x + y = 150$$

$$\text{So, } 0.5x = 34, x = 68, y = 82$$

18. If 391 bananas was distributed among three monkeys in the ratio $\frac{1}{2} : \frac{2}{3} : \frac{3}{4}$, how many bananas did the first monkey get?

- (a) 102 (b) 108
 (c) 112 (d) 104

Ans. (a)

$$\frac{1}{2} : \frac{2}{3} : \frac{3}{4} = \frac{6:8:9}{12}$$

Bananas are in ratio $6x : 8x : 9x$

It is given that

$$6x + 8x + 9x = 391$$

$$23x = 391, x = 17$$

first monkey get 102 bananas

19. A mixture contains milk and water in the ratio 5 : 1. On adding 5 litres of water, the ratio of milk to water becomes 5 : 2. The quantity of milk in the mixture is:

- (a) 16 litres (b) 25 litres
(c) 32.5 litres (d) 22.75 litres

Ans. (b)

Let milk and water are $5x : x$

$$\text{now, } \frac{5x+5}{x+5} = \frac{5}{2}$$

$$= 10x = 5x + 25$$

$$5x = 25, \quad x = 5$$

$$\text{milk : water} = 25 : 10$$

20. Vijay has coins of the denomination of Re. 1, 50p and 25 p in the ratio of 12 : 10 : 7. The total worth of the coins he has in Rs. 75. Find the number of 25 p coins that Vijay has

- (a) 48 (b) 72
(c) 60 (d) None of these

Ans. (d)

Coins are $12x : 10x : 7x$

$$\text{It is given that } 12x + 10x \times \frac{1}{2} + \frac{7}{4}x = 75$$

$$\frac{48x + 20x + 7x}{4} = 75$$

$$75x = 4 \times 75, \quad x = 4$$

21. If two numbers are in the ratio of 5 : 8 and if 9 be added to each, the ratio becomes 8 : 11. Now find the lower number.

- (a) 5 (b) 10
(c) 15 (d) None of these

Ans. (c)

Let number are $5x$ and $8x$ then it is given that

$$\frac{5x+9}{8x+9} = \frac{8}{11}$$

$$55x + 99 = 64x + 72$$

$$27 = 9x, \quad x = 3$$

Number are 15 and 24

22. If x varies as y , and $y = 7$ when $x = 18$, find x when $y = 21$

- (a) 36 (b) 54
(c) 72 (d) 18

Ans. (b)

x is directly proportional to y

$$\text{So, } x = k.y$$

$$18 = 7k$$

$$\text{So, } k = \frac{18}{7}$$

$$\text{now, } x = \frac{18}{7} \times 21 = 54$$

23. A varies jointly as B and C; and $A = 6$ when $B = 3, C = 2$; find A when $B = 5, C = 7$.

- (a) 17.5 (b) 35
(c) 70 (d) 105

Ans. (b)

Let $A = k(BC)$ then

$$6 = k(3 \cdot 2)$$

$$\text{So, } k = 1 \text{ then}$$

$$A = k(BC)$$

$$= 1 \times (5 \times 7) = 35$$

24. If x varies as y directly, and as z inversely and $x = 14$, when $y = 10$; find z when $x = 49$, $y = 45$.

- (a) 14/10
(b) 10
(c) 10/14
(d) Cannot be determined

Ans. (d)

$$x = k_1 y \quad x = \frac{k_2}{z}$$

According to given values

$$14 = k_1 \cdot 10$$

$$\text{So, } k_1 = \frac{14}{10} = \frac{7}{5}$$

$$\text{also, } 14 = \frac{k_2}{z}$$

$$\text{So, } k_2 = 14z,$$

But value of k_2 is not given
hence Z cannot be determined.

25. A cask contains a mixture of 49 litres of wine and water in the proportion 5 : 2. How much water must be added to it so that the ratio of wine to water may be 7 : 4?

- (a) 3.5 (b) 6
(c) 7 (d) None of these

Ans. (b)

Let wine and water are $5x$ and $2x$ litres

$$5x + 2x = 49$$

$$5x = 35, \quad 2x = 14$$

$$\text{now } \frac{35}{14+w} = \frac{7}{4}$$

$$98 + 7w = 140$$

$$7w = 42, \quad w = 6$$

□□□□

Ratio & Proportion



Practice Exercise: I

- Find a fourth proportional to the numbers 60, 48, 30.
(a) 36 (b) 24
(c) 48 (d) None of these
- Find a third proportional to the numbers 4, 42.
(a) 441 (b) 541
(c) 641 (d) None of these
- In a ratio 11 : 14, if the antecedent is 55, the consequent is
(a) 70 (b) 90
(c) 60 (d) None of these
- The mean proportional of 0.25 and 0.04 is
(a) 0.01 (b) 0.1
(c) $10\sqrt{10}$ (d) None of these
- The ratio of two numbers is 3 : 4 and their sum is 420. The greater of the two numbers is
(a) 360 (b) 240
(c) 180 (d) None of these
- Amit, Sumit and Puneet share an amount of Rs. 660 in the ratio of 3 : 4 : 5. What is the share of Puneet?
(a) Rs. 375 (b) Rs. 275
(c) Rs. 575 (d) None of these
- The prices of a scooter and a television set are in the ratio of 3 : 2. If a scooter costs Rs. 600 more than the television set, then the price of television set is:
(a) Rs. 1800 (b) Rs. 1200
(c) Rs. 2400 (d) None of these
- If $A : B = 7 : 5$ and $B : C = 9 : 11$, then $A : B : C$ is equal to
(a) 55:45:63 (b) 63:45:55
(c) 45:63:55 (d) None of these
- If $3A = 4B = 5C$, then $A : B : C$ is
(a) 16:20:18 (b) 15:20:16
(c) 20:15:12 (d) None of these
- The ratio of money with Anju and Sanju is 4 : 5 and that with Sanju and Manju is 5 : 6. If Anju has Rs. 280, then the amount of money Manju has
(a) Rs. 320 (b) Rs. 420
(c) Rs. 640 (d) None of these

11. The sum of three number is 124. If the ratio between the first and second be 2 : 3 and that between the second and third be 7 : 9, then the third number is:
 (a) 54 (b) 64
 (c) 48 (d) None of these
12. The ratio between two number is 2 : 3. If each number is increased by 4, the ratio becomes 5 : 7. The number are
 (a) 8, 16 (b) 16, 24
 (c) 24, 32 (d) None of these
13. The ratio of present ages of Suresh and Mahesh is 7 : 5. If after 6 years their ages will be in the ratio of 4 : 3, the present age of Mahesh is
 (a) 32 years (b) 36 years
 (c) 30 years (d) None of these
14. Two numbers are in the ratio of 5 : 7. If 25 be subtracted from each, they are in the ratio of 35 : 59. Find the difference of the two numbers.
 (a) 48 (b) 52
 (c) 24 (d) None of these
15. The value of k that must be added to 7, 16, 43, 79 so that they are in proportion, is
 (a) 7 (b) 5
 (c) 9 (d) None of these
16. The number that must be added to each of the numbers 8, 21, 13 and 31 to make the ratio of first two numbers equal to the ratio of last two number is
 (a) 5 (b) 7
 (c) 9 (d) None of these
17. The incomes of A and B are in the ratio 3 : 2 and their expenditures in the ratio 5 : 3. If each saves Rs. 1000, A's income is
 (a) Rs. 5000 (b) Rs. 6000
 (c) Rs. 8000 (d) None of these

18. A mixture contains alcohol and water in the ratio of 12 : 5. On adding 14 litres of water, the ratio of alcohol to water becomes 4 : 3. The quantity of alcohol in the mixture is
 (a) 18 litres (b) 42 litres
 (c) 26 litres (d) None of these

Solutions

1. Ans. (b)
 Let x be the fourth proportional, then
 $60 : 48 :: 38 : x$ or, $\frac{60}{48} = \frac{38}{x}$
 $\therefore x = \frac{30 \times 38}{60} = 24.$
2. Ans. (a)
 Let x be the third proportional, then
 $4 : 42 :: 42 : x$ or, $\frac{4}{42} = \frac{42}{x}$
 $\therefore x = \frac{42 \times 42}{4} = 441.$
3. Ans. (a)
 $\frac{11}{14} = \frac{11 \times 5}{14 \times 5} = \frac{55}{70}$
 \therefore Consequent = 70.
4. Ans. (b)
 Let x be the mean proportional. Then,
 $0.25 : x :: x : 0.04$
 or, $\frac{0.25}{x} = \frac{x}{0.04}$
 or, $x^2 = 0.01$
 or, $x = 0.1$
5. Ans. (b)
 Here, a = 3, b = 4 and x = 420.
 \therefore The first number

$$= \frac{ax}{a+b} = \frac{3 \times 420}{3+4} = 180.$$

and, the second number

$$= \frac{bx}{a+b} = \frac{4 \times 420}{3+4} = 240.$$

6. Ans. (b)

Here, $a = 3$, $b = 4$, $c = 5$ and $x = 660$.

$$\therefore \text{Share of Puneet} = \frac{cx}{a+b+c}$$

$$= \frac{5 \times 660}{3+4+5} = \text{Rs.} 275.$$

7. Ans. (b)

Here, $a = 3$, $b = 2$, and $x = 600$.

\therefore The price of a television set

$$= \frac{bx}{a-b} = \frac{2 \times 600}{3-2} = \text{Rs.} 1200.$$

8. Ans. (b)

Here, $n_1 = 7$, $n_2 = 9$, $d_1 = 5$ and $d_2 = 11$.

$$\therefore A : B : C = (n_1 \times n_2) : (d_1 \times n_2) : (d_1 \times d_2)$$

$$= (7 \times 9) : (5 \times 9) : (5 \times 11)$$

$$= 63 : 45 : 55.$$

9. Ans. (c)

We have $A : B = 4 : 3$ and $B : C = 5 : 4$.

Here, $n_1 = 4$, $n_2 = 5$, $d_1 = 3$ and $d_2 = 4$.

$$\therefore A : B : C = (n_1 \times n_2) : (d_1 \times n_2) : (d_1 \times d_2)$$

$$= (4 \times 5) : (3 \times 5) : (3 \times 4)$$

$$= 20 : 15 : 12.$$

10. Ans. (b)

We have, $A : B = 4 : 5$ and $B : C = 5 : 6$.

Here, $n_1 = 4$, $n_2 = 5$, $d_1 = 5$ and $d_2 = 6$.

$$\therefore A : B : C = (n_1 \times n_2) : (d_1 \times n_2) : (d_1 \times d_2)$$

$$= (4 \times 5) : (5 \times 5) : (5 \times 6)$$

$$= 20 : 25 : 30 \text{ or, } 4 : 5 : 6.$$

Thus, ratio of money with Anju, Sanju and Manju is $4 : 5 : 6$. Since Anju has Rs. 280, the amount of money Manju has

$$= \frac{280}{4} \times 6 = \text{Rs.} 420.$$

11. Ans. (a)

We have, $A : B = 2 : 3$ and $B : C = 7 : 9$.

Here, $n_1 = 2$, $n_2 = 7$, $d_1 = 3$ and $d_2 = 9$.

$$\therefore A : B : C = (n_1 \times n_2) : (d_1 \times n_2) : (d_1 \times d_2)$$

$$= (2 \times 7) : (3 \times 7) : (3 \times 9)$$

$$= 14 : 21 : 27.$$

Since the sum of the numbers is 124, the third

$$\text{number is } \frac{27}{14+21+27} \times 124 = 54.$$

12. Ans. (b)

We have, $a : b = 2 : 3$, $c : d = 5 : 7$ and $x = 4$.

$$\therefore \text{The first number} = \frac{ax(c-d)}{ad-bc}$$

$$= \frac{2 \times 4 \times (5-7)}{(2 \times 7 - 3 \times 5)} = 16.$$

$$\text{and, the second number} = \frac{bx(c-d)}{ad-bc}$$

$$= \frac{3 \times 4 \times (5-7)}{(2 \times 7 - 3 \times 5)} = 24.$$

13. Ans. (c)

We have, $a : b = 7 : 5$, $c : d = 4 : 3$ and $x = 6$.

$$\therefore \text{The present age of Mahesh} = \frac{bx(c-d)}{ad-bc}$$

$$= \frac{5 \times 6 \times (4-3)}{(7 \times 3 - 5 \times 4)} = 30 \text{ years.}$$

14. Ans. (c)

We have, $a : b = 5 : 7$, $c : d = 35 : 59$ and $x = 25$.

$$\therefore \text{The first number} = \frac{ax(d-c)}{ad-bc}$$

$$= \frac{5 \times 25 \times (59-35)}{(5 \times 59 - 7 \times 35)} = 60.$$

$$\text{and, the second number} = \frac{bx(d-c)}{ad-bc}$$

$$= \frac{7 \times 25 \times (59 - 35)}{(5 \times 59 - 7 \times 35)} = 84$$

$$\therefore \text{The difference of two numbers} \\ = 84 - 60 = 24$$

15. Ans. (b)

Here, $a = 7$, $b = 16$, $c = 43$ and $d = 79$.

$$\therefore k = \frac{bc - ad}{(a + d) - (b + c)} \\ = \frac{16 \times 43 - 7 \times 79}{(7 + 79) - (16 + 43)} = 5.$$

16. Ans. (a)

Here, $a = 8$, $b = 21$, $c = 13$ and $d = 31$.

\therefore The required number

$$= \frac{bc - ad}{(a + d) - (b + c)} \\ = \frac{21 \times 13 - 8 \times 31}{(8 + 31) - (21 + 13)} = 5.$$

17. Ans. (b)

We have, $a : b = 3 : 2$, $c : d = 5 : 3$ and $s = 1000$.

$$\therefore \text{A's income} = \frac{aS(d - c)}{ad - bc} \\ = \frac{3 \times 1000 \times (3 - 5)}{(3 \times 3 - 2 \times 5)} = \text{Rs. } 6000.$$

18. Ans. (b)

The two given ratios are $12 : 5$ and $4 : 3$.

In order to equate the antecedents of the two ratios, we write the second ratio as $12 : 9$.

Now, we have, $a : b = 12 : 5$, $c : d = 12 : 9$ and $x = 14$.

\therefore The quantity of alcohol in the mixture

$$= \frac{ax}{c - b} = \frac{12 \times 14}{12 - 5} = 24 \text{ litres.}$$

□□□□

Partnership



Practice Exercise: I

- Aman and Pranjal enter into a partnership investing Rs. 50000 and Rs. 40000, respectively. They agree to share profits in the ratio of their capitals. Find the share of Aman in a profit of Rs. 22500 after one year.
 - Rs. 12500
 - Rs. 9500
 - Rs. 10500
 - None of these
- Amit, Nitin and Ravindra entered into a partnership. Amit invested Rs. 16000 for 9 months. Nitin invested Rs. 12000 for 6 months and Ravindra invested Rs. 8000 for 12 months. At the end of a year there was a profit of Rs. 26000. Find the share of Nitin in the profit.
 - Rs. 8000
 - Rs. 7500
 - Rs. 6000
 - None of these
- A starts business with Rs. 3500 and 5 months after B joins A as his partner. After a year the profits are divided in the ratio of $2 : 3$. How much did B contribute?
 - Rs. 7000
 - Rs. 11000
 - Rs. 9000
 - None of these
- Arvind began a business with Rs. 550 and was joined afterwards by Naveen with Rs. 330. When did Naveen join if the profits at the end of the year were divided in the ratio $10 : 3$?
 - After 4 months
 - After 6 months
 - After 4.5 months
 - None of these
- A, B and C invested capitals in the ratio $3 : 5 : 9$; the timing of their investments being in the ratio $2 : 3 : 1$. In what ratio would their profits be distributed?
 - $2 : 5 : 3$
 - $3 : 2 : 5$
 - $7 : 5 : 3$
 - None of these

6. A, B and C start a business. If the ratio of their periods of investments are 2 : 3 : 6 and their profits are in the ratio of 4 : 5 : 6, then the ratio of capitals of A, B and C is
 (a) 6 : 8 : 10 (b) 12 : 10 : 6
 (c) 10 : 12 : 6 (d) None of these
7. A, B, C and D enter into partnership. A subscribes $\frac{1}{3}$ of the capital, B $\frac{1}{4}$, C $\frac{1}{5}$ and D the rest. What is the share of D out of a profit of Rs. 6000?
 (a) Rs. 2000 (b) Rs. 1600
 (c) Rs. 1200 (d) Rs. 1300
8. A and B started a business with initial investments in the ratio 5 : 7. If after one year their profits were in the ratio 1 : 2 and the period for A's investment was 7 months, B invested the money for
 (a) 6 months (b) $2\frac{1}{2}$
 (c) 10 months (d) 4 months
9. A, B, C enter into a partnership with shares in the ratio $\frac{7}{2} : \frac{4}{3} : \frac{6}{5}$. After 4 months, A increase his share by 50%. If the total profit at the end of one year be Rs. 21600, then B's share in the profit is
 (a) Rs. 2100 (b) Rs. 2400
 (c) Rs. 3600 (d) Rs. 4000
10. B is a sleeping partner and A working. A puts in Rs. 5000 and B puts in 6000. A received 12.5% of profit for managing the business and rest is divided in proportion to their capitals. A's share of profit in a profit of Rs. 880 is
 (a) Rs. 350 (b) Rs. 400
 (c) Rs. 420 (d) Rs. 460
11. A starts business with a capital of Rs. 1200. B and C join with some investments after 3 and 6 months, respectively. If at the end of

a year, the profit is divided in the ratio 2 : 3 : 5 respectively, what is B's investment in the business?

- (a) Rs. 2400 (b) Rs. 1800
 (c) Rs. 3600 (d) Rs. 6000

Solutions

1. Ans. (a)

Here, $C_1 = 50000$, $C_2 = 40000$ and $P = 22500$.

$$\therefore C_1 + C_2 = 50000 + 40000 = 90000.$$

$$\therefore \text{Nikita's Share} = \frac{C_1 \times P}{C_1 + C_2}$$

$$= \frac{50000 \times 22500}{90000}$$

$$= \frac{5}{9} \times 22500 = \text{Rs. } 12500.$$

2. Ans. (c)

Here, $C_1 = 16000$, $C_2 = 12000$, $C_3 = 8000$,

$t_1 = 9$, $t_2 = 6$, $t_3 = 12$ and $P = 26000$.

Nitin's share in the profit

$$= \frac{C_2 \times t_2 \times P}{C_1 t_1 + C_2 t_2 + C_3 t_3}$$

$$= \frac{12000 \times 6 \times 26000}{16000 \times 9 + 12000 \times 6 + 8000 \times 12}$$

$$= \frac{1872000000}{312000} = \text{Rs. } 6000.$$

3. Ans. (c)

We have, $C_1 \times t_1 = 3500 \times 12 = 42000$ and

$C_2 \times t_2 = x \times 7 = 7x$.

$$\text{Then, } \frac{\text{Profit for A}}{\text{Profit for B}} = \frac{C_1 \times t_1}{C_2 \times t_2}$$

$$\Rightarrow \frac{2}{3} = \frac{42000}{7x}$$

$$\text{or, } x = \frac{42000 \times 3}{2 \times 7} = \text{Rs. } 9000.$$

4. Ans. (b)

Let Naveen remain in the business for x months.We have, $C_1 \times t_1 = 550 \times 12 = 6600$ $C_2 \times t_2 = 330 \times x = 330x$.

$$\therefore \frac{\text{Arvind's share of profit}}{\text{Naveen's share of profit}} = \frac{C_1 \times t_1}{C_2 \times t_2}$$

$$\Rightarrow \frac{10}{3} = \frac{6600}{330x} \Rightarrow x = \frac{6600 \times 3}{330 \times 10} = 6 \text{ months.}$$

5. Ans. (a)

Ratio of capitals of A, B and C are 3 : 5 : 9.

Let the capitals of A, B and C be $3x$, $5x$ and $9x$, respectively.Ratio of timing of their investments are 2 : 3 : 1. Let A, B and C invest their capitals for $2y$, $3y$ and y months, respectively.

Then, profit of A : profit of B : Profit of C

$$\begin{aligned} &= C_1 \times t_1 : C_2 \times t_2 : C_3 \times t_3 \\ &= 3x \times 2y : 5x \times 3y : 9x \times y \\ &= 6 : 15 : 9 \text{ or, } 2 : 5 : 3. \end{aligned}$$

6. Ans. (b)

We have, $P_1 : P_2 : P_3 = 4 : 5 : 6$ and $t_1 : t_2 : t_3 = 2 : 3 : 6$.

$$\therefore \text{Required ratio} = \frac{P_1}{t_1} : \frac{P_2}{t_2} : \frac{P_3}{t_3} = \frac{4}{2} : \frac{5}{3} : \frac{6}{6}$$

or, 12 : 10 : 6

Thus, A, B and C invested their capitals in the ratio 12 : 10 : 6.

7. Ans. (d)

$$\text{D's Capital} = 1 - \frac{1}{3} - \frac{1}{4} - \frac{1}{5} = \frac{13}{60}$$

$$\text{Profit ratio of A, B, C, D is } \frac{1}{3} : \frac{1}{4} : \frac{1}{5} : \frac{13}{60}$$

 $\therefore 20 : 15 : 12 : 13$

$$\therefore \text{Share of D} = \frac{13}{60} \times \text{Rs. } 6000 = \text{Rs. } 1300.$$

8. Ans. (c)

Let investments of A and B respectively be $5x$ and $7x$ and period of B's investment be y months.

$$\text{Then, } \frac{(5x) \times 7}{(7x) \times y} = \frac{1}{2} \Rightarrow y = 10.$$

9. Ans. (d)

$$\text{Given ratio} = \frac{7}{2} : \frac{4}{3} : \frac{6}{5} = 105 : 40 : 36$$

Let the initially invest Rs. 105, Rs. 40 and Rs. 36, respectively.

Ratio of investments

$$\begin{aligned} &= [105 \times 4 + (150\% \text{ of } 105) \times 8] : (40 \times 12) \\ &\quad : (36 \times 12) \\ &= 1680 : 480 : 432 = 35 : 10 : 9 \end{aligned}$$

$$\text{B's share} = \text{Rs.} \left(21600 \times \frac{10}{54} \right) = \text{Rs. } 4000.$$

10. Ans. (d)

A's share for managing the business

= 12.5% of Rs. 880 = Rs. 110

Remaining profit = Rs. 770.

Profit ratio of A and B = 5 : 6

$$\text{A's share} = \frac{5}{11} \text{ of Rs. } 770 = \text{Rs. } 350.$$

A's total profit = Rs. 350 + Rs. 110 = Rs. 460.

11. Ans. (a)

Profit ratio of A, B and C is

$$(1200 \times 12) : (x \times 9) : (y \times 6) = 2 : 3 : 5$$

$$\Rightarrow \frac{1200 \times 12}{2} = \frac{9x}{3}$$

 $\therefore x = \text{Rs. } 2400.$ 



Percentage

The term percent means "for every 100". It is derived from french word 'Cent' which is 100 for french.

The basic utility of percentage arises from the fact that it is one of the most powerful tool for comparison of numerical data and information. It is also one of the simplest tool for comparison of data.

In the context of business and economic performance, it is specifically, useful for comparing data such as profits, growth rates, magnitude and so on.

Calculation

Since percentage represent the value obtained out of every 100, calculation can be done in following manner

$$\text{Percentage} = \frac{\text{Value obtained}}{\text{Total value}} \times 100$$

For example, let in IIT JEE examination Sanjay scored 135 marks out of 300 marks, Then Marks obtained by Sanjay in % term is equal to

$$\frac{135}{300} = 45\%$$

As discussed earlier, percentage is amongst the most powerful tool for comparison, let for example

Sweta scored 120 marks out of 150 and Rahul scored 360 marks out of 500 then Percentage

$$\text{score of Sewta} = \frac{120}{150} = 80\%$$

$$\text{Percentage score of Rahul} = \frac{360}{500} = 72\%$$

Thus, it clearly shows that Sweta's performance is better than Rahul's performance.

Other Comparison

Let in Annual Examination Megha obtained 200 marks out of 300 and Sangeeta obtained 100 marks out of 300, Now to compare marks of Megha and Sangeeta two question arise

1. Megha's marks is how much percentage greater than Sangeeta's marks?
2. Sangeeta's marks is how much percentage less than Megha's marks obtained?

Megha 200

Sangeeta 100

Clearly Megha's marks is 100 greater than Sangeeta's marks. Its means

$$\frac{\text{difference of marks}}{\text{Sangeeta marks}} = \frac{100}{100} = 100\%$$

Now Sangeeta's marks is 100 less than Megha's it means

$$\frac{\text{difference of marks}}{\text{Megha's marks}} = \frac{100}{200} = 50\%$$

From this we can come at the result that Megha's marks is 100% greater than Sangeeta's marks while Sangeeta's marks is 50% less than Megha's marks.

Some Useful Short cut Methods

1.(a) If A is $x\%$ more than that of B then B is less than that of A by

$$\left[\frac{x}{100+x} \times 100 \right] \%$$

1.(b) If A is $x\%$ less than that of B then B is more than that of A by

$$\left[\frac{x}{100-x} \times 100 \right] \%$$

Example: 1. If Shailendra's salary is 20% more than that of Surendra, then how much percent is salary of Surendra less than that of Shailendra.

Solution: Here $x = 20$

$$\begin{aligned} \therefore \text{Required Answer} &= \left[\frac{x}{100+x} \times 100 \right] \% \\ &= \frac{20}{120} \times 100\% = 16.66\% \end{aligned}$$

Example: 2. If A's income is 30% less than that of B's income, then how much percent is B's income more than A's income.

Solution: Here $x = 30$

$$\begin{aligned} \therefore \text{Required Answer} &= \left(\frac{x}{100-x} \times 100 \right) \% \\ &= \left(\frac{30}{70} \times 100 \right) \% = 42.8\% \end{aligned}$$

2. If A is $x\%$ of C and B is $y\%$ of C then

$$A = \frac{x}{y} \times 100\% \text{ of B}$$

Example: If A is 20% of C and B is 25% of C then what percentage is A of B.

Solution: Here $x = 20$, $y = 25$

$$A = \frac{x}{y} \times 100 = \frac{20}{25} \times 100 = 80\% \text{ of B}$$

3.(a) If the price of a commodity increase by $P\%$, then the reduction in consumption so as not to increase the expenditure is

$$\left(\frac{P}{100+P} \times 100 \right) \%$$

3.(b) If the price of a commodity decrease by $P\%$ then the increase in consumption so as not to decrease the expenditure is

$$\left(\frac{P}{100-P} \times 100 \right) \%$$

Example: 3(a) If the price of sugar increase by 25%. Find how much percent its consumption be reduced so as not to increase the expenditure.

Solution: Reduction in consumption

$$\begin{aligned} &= \left(\frac{P}{100+P} \times 100 \right) \% \\ &= \frac{25}{125} \times 100\% = 20\% \end{aligned}$$

Example: 3(b) If price of commodity decrease by 25%, find how much percent its consumption be increased so as not to decrease the expenditure.

Solution: Increase in consumption

$$\begin{aligned} &= \frac{P}{100-P} \times 100\% \\ &= \frac{25}{100-25} \times 100\% \end{aligned}$$

4. If a number is changed (increased/decreased) successively by $x\%$ and $y\%$ then

net% change is given by $\left(x + y + \frac{xy}{100}\right)\%$

which represent increase or decrease in value according as the sign in (+)ve or (-)ve.

If x or y indicates decrease in percentage then put (-)ve sign before x or y, otherwise (+)ve sign.

Example: 4.(a) If salary of a person is increased by 10% and 20% successively then, what is the change in his salary?

Solution: Here $x = 10$, $y = 20$

\therefore The net % change in the salary

$$= \left(10 + 20 + \frac{10 \times 20}{100}\right)\% = 32\%$$

Example: (4b) The price of a commodity first increased by 20% then decreased by 10% then what is the net change price of commodity.

Solution: here $x = 20$, $y = -10$ then net percent change in price is

$$\left[20 - 10 + \frac{20 \times (-10)}{100}\right]\% = 8\%$$

Here sign is (+ve) hence the net is (+ve) increase in price.

Example: (4c) If price of a commodity decreased first by 20% and then by 30% then find the net change in price?

Solution: Here $x = 20$, $y = 30$

\therefore Net % change is

$$\left[-20 - 30 + \frac{-20 \times -30}{100}\right]\% = -44\%$$

Since sign is (-)ve the net change is reduction in price

5. If the present population of a town (or value of an item) be P and the population (or value of item) changes in r% per annum, then
- (a) Population (or value of an item) after n

$$\text{years ago} = P \left(1 + \frac{r}{100}\right)^n$$

(b) Population (or value of an item) n years

$$\text{ago} = \frac{P}{\left(1 + \frac{r}{100}\right)^n}$$

Where r is (+ve) or (-)ve according as the population (or value of item) increase or decreases.

Example:

The population of a town increases 10% annually. If its present population is 120000, what will it be in 2 years time.

Solution: Here $P = 120000$, $r = 10$, $n = 2$.

\therefore Population after 2 years

$$= P \left(1 + \frac{r}{100}\right)^n = 120000 \left[1 + \frac{10}{100}\right]^2$$

$$= 120000 \times \frac{110}{100} \times \frac{110}{100} = 145200$$

Example: The population of a town increase at the rate of 20% annually due to excessive migration. If present population is 144000 find population two years ago.

Solution: Here $P = 144000$, $r = 20$

\therefore Population of the town two years ago

$$= \frac{P}{\left(1 + \frac{r}{100}\right)^n}$$

$$= \frac{144000}{\left(1 + \frac{20}{100}\right)^2} = \frac{144000}{\frac{120}{100} \times \frac{120}{100}} = 100000$$

6. If a number A is increased by x%, y% and 2% successively then final value of A will be

$$A \left(1 + \frac{x}{100}\right) \left(1 + \frac{y}{100}\right) \left(1 + \frac{z}{100}\right)$$

In case a given value decrease by an percentage, we will use a (-)ve sign before that.

Example: (6) The income of Ramesh increase by 10%, 20% and 30% successively in three years find change in his income if present income is 150000 Rs. per annum

Solution: Here $x = 10$, $y = 20$, $z = 30$,
 $A = 150000$

So, percent change in income

$$\begin{aligned} & A \left(1 + \frac{x}{100} \right) \left(1 + \frac{y}{100} \right) \left(1 + \frac{z}{100} \right) \\ &= 150000 \times \left[\left(1 + \frac{10}{100} \right) \left(1 + \frac{20}{100} \right) \left(1 + \frac{30}{100} \right) \right] \\ &= 150000 \times \frac{110}{100} \times \frac{120}{100} \times \frac{130}{100} = \text{Rs. } 257400 \end{aligned}$$

1. To convert fraction into percent

to convert any fraction $\frac{l}{m}$ to rate per unit multiply it by 100.

For example 1. $\frac{3}{5} = \frac{3}{5} \times 100 = 60\%$

For example 2. $\frac{5}{6} = \frac{5}{6} \times 100 = 83.33\%$

2. To convert a percent into a fraction

To convert percent into fraction, drop the % sign and divide the number by 100.

Example: What fraction is $16\frac{2}{3}\%$

Solution: $16\frac{2}{3}\% = \frac{50}{3} = \frac{50}{300} = \frac{1}{6}$

3. To find a percentage of given number

% of given number (N) = $\frac{x}{100} \times N$

Example: 1 65% of 300=?

Solution: $\frac{65}{100} \times 300 = 795$

Example: 2 Find a number whose 4% is 72.

Solution: Here $72 = \frac{4}{100} \times x$

$72 = \frac{1}{25} x$, $x = 72 \times 25 = 1800$

Example: 3 What percentage of 30 kg is 2.5 kg.

Solution: $\frac{2.5}{30} \times 100 = \frac{1}{12} \times 100 = 8.33\%$



Solved Examples

1. Which of the following is the largest number?

- (a) 20% of 200 (b) 7% of 500
 (c) 1300% of 3 (d) 600% of 7

Ans. (d)

20% of 200 = 40

7% of 500 = 35

1300% of 3 = 39

600% of 7 = 42

2. If 25% of a number is 75, then 45% of that number is:

- (a) 145 (b) 125
 (c) 150 (d) 135

Ans. (d)

$= \frac{25}{100} \times x = 75$

$x = \frac{75 \times 100}{25}$, $x = 300$

45% of 300 = 135

So quantity of sugar that can be purchased

$$= \frac{\frac{6}{5}E}{\frac{3}{4}x} = \frac{8E}{5x} = 160\% \text{ of } \frac{E}{x}$$

15. The price of rice falls by 20%. How much rice can be bought now with the money that was sufficient to buy 20 kg of rice previously?

- (a) 5 kg (b) 15 kg
(c) 25 kg (d) 30 kg

Ans. (c)

Fall in price by 20%
now with same price one can purchase

$$\frac{x}{100-x} \times 100\% \text{ more.}$$

$$\frac{20}{100-20} \times 100\% = 25\% \text{ more.}$$

$$25\% \text{ of } 20 = 5 \text{ kg}$$

$$\text{So total sugar} = 20 + 5 = 25 \text{ kg}$$

16. 30% of a number when subtracted from 91, gives the number itself. Find the number.

- (a) 60 (b) 65
(c) 70 (d) None of these

Ans. (c)

$$\frac{30}{100}x = 30\% \text{ of number } x$$

$$\text{Now } 91 - \frac{30}{100}x = x$$

$$91 = \frac{130}{100}x, x = 70$$

17. The population of a village is 1,00,000. The rate of increase is 10% per annum. Find the population at the start of the third year?

- (a) 1,33,100 (b) 1,21,000
(c) 1,20,000 (d) None of these

Ans. (b)

here $P = 100000$, $r = 10\%$, $n = 2$ year (At the start of third year i.e. after two year)

$$P \left(1 + \frac{r}{100}\right)^n$$

$$= 100000 \left(1 + \frac{10}{100}\right)^2 = 121000$$

18. The population of the village of Rampur is 10,000 at this moment. It increases by 10% in the first year. However, in the second year, due to immigration, the population drops by 5%. Find the population at the end of the third year if in the third the population increases by 20%.

- (a) 12,340 (b) 12,540
(c) 1,27,540 (d) 12,340

Ans. (b)

$$P = 10000, x = +10\%, y = -5\%, z = 20\%$$

Population at the end of third year

$$= P \left(1 + \frac{x}{100}\right) \left(1 + \frac{y}{100}\right) \left(1 + \frac{z}{100}\right)$$

$$= 10000 \left(1 + \frac{10}{100}\right) \left(1 - \frac{5}{100}\right) \left(1 + \frac{20}{100}\right)$$

$$= 12540$$

19. In an examination, Mohit obtained 20% more than Sushant but 10% less than Rajesh. If the marks obtained by Sushant is 1080, find the percentage marks obtained by Rajesh if the full marks is 2000.

- (a) 86.66% (b) 72%
(c) 78.33% (d) None of these

Ans. (b)

Marks obtained by Shushant is 1080

$$\text{Mohit's marks} = \frac{120}{100} \times 1080 = 1296$$

$$\text{Rajesh Marks, } R \Rightarrow \frac{90}{100} \times R = 1296$$

$$R = 1440$$

$$\% \text{ of Rajesh Marks} = \frac{1440}{2000} \times 100 = 72\%$$

20. Ram spends 20% of his monthly income on his house hold expenditure, 15% of the rest of books, 30% of the rest on clothes and saves the rest. On counting, he comes to know that he has finally saved Rs. 9520. Find his monthly income.

- (a) 10000 (b) 15000
(c) 20000 (d) None of these

Ans. (c)

Let he earns P Rupees

$$x = -20, y = -15, z = -30$$

$$P \left[1 + \frac{x}{100} \right] \left[1 + \frac{y}{100} \right] \left[1 + \frac{z}{100} \right] = 9520$$

$$P \left[\frac{80}{100} \right] \times \left[\frac{85}{100} \right] \left[\frac{70}{100} \right] = 9520$$

$$Px. 476 = 9520, P = 20000$$

21. The population of a village is 5500. If the number of males increases by 11% and the number of females increases by 20%, then the population becomes 6330. Find the population of females in the town.

- (a) 2500 (b) 3000
(c) 2000 (d) 3500

Ans. (a)

x is population of male

∴ $(5500 - x)$ is female population

$$\frac{x \times 111}{100} + \frac{(5500 - x) \times 120}{100} = 6330$$

On calculating we get $x = 3000$

So female population = 2500.

22. Vicky's salary is 75% more than Ashu's. Vicky got a raise of 40% on his salary while Ashu got a raise of 25% on his salary. By what percent is Vicky's salary more than Ashu's?

- (a) 96% (b) 51.1%
(c) 90% (d) 52.1%

Ans. (a)

Let's Ashu's salary = 100 Rs.

Vicky's salary = 175 Rs.

Vicky's salary increased by 40% i.e.

$$= \frac{140}{100} \times 175 = 245 \text{ Rs.}$$

Ashu's salary increased by 25% ie 125

Vicky's Salary is 120 more than Ashu's in %

$$\text{term } \frac{120}{125} \times 100 = 96\%$$

23. An ore contains 25% of an alloy that has 90% iron. Other than this, in the remaining 75% of the ore, there is no iron. How many kilograms of the ore are needed to obtain 60 kg of pure iron?

- (a) 250 kg (b) 275 kg
(c) 300 kg (d) 266.66 kg

Ans. (d)

Let amount of ore is 100 kg

25% or 25 kg has 90% iron

$$= \frac{25 \times 90}{100} = 22.5 \text{ kg iron}$$

75% or 75 kg has no iron = 0 kg

To obtain 22.5 kg 100 kg ore is required

So to obtain 60 kg

$$\frac{100}{22.5} \times 60 = 266.66 \text{ kg}$$

24. The population of a village is 1,00,000. Increase rate per annum is 10%. Find the population at the starting of the fourth year.

- (a) 1,33,100 (b) 1,21,000
(c) 1,33,000 (d) None of these

Ans. (a)

Here $P = 100000, r = 10, n = 3$

Population at the starting of fourth year is

$$100000 \left[1 + \frac{10}{100} \right]^3 = 133100$$

3. What is 20% of 50% of 75% of 70?

- (a) 5.25 (b) 6.75
(c) 7.25 (d) 2.5

Ans. (a)

20% of 50% of 75% of 70

$$= \frac{20}{100} \times \frac{30}{100} \times \frac{75}{100} \times 70 = 5.25$$

4. Mr. Rajesh is worried about the balance of his monthly budget. The price of petrol has increased by 40%. By what percent should he reduce the consumption of petrol so that he is able to balance his budget?

- (a) 33.33 (b) 28.56
(c) 25 (d) None of these

Ans. (b)

We know that % reduction required is

$$= \frac{x}{100+x} \times 100 \text{ here } x=40$$

$$= \frac{40}{140} \times 100 = 28.56\%$$

5. Ram sells his goods 25% cheaper than Shyam and 25% dearer than Bram. How much percentage is Bram's goods cheaper than Shyam's?

- (a) 33.33% (b) 50%
(c) 66.66% (d) 40%

Ans. (d)

Let Shyam sell good at Rs. 100

So Ram sell good at 75 Rs.

Now this 75 Rs. is 25% dearer than Bram i.e.

$$\text{Bram} \times \frac{125}{100} = 75$$

Bram's price = 60

Bram's good is 40 Rs. cheaper than Shyam

$$\text{in \% term } \frac{40}{100} \times 100 \text{ i.e. } 40\%$$

6. In an election between 2 candidates, Ravikant gets 65% of the total valid votes. If the total votes were 6000, what is the number of valid

votes that the other candidate Shailendra gets if 25% of the total votes were declared invalid?

- (a) 1625 (b) 1575
(c) 1675 (d) 1525

Ans. (b)

Total votes 6000

invalid votes = 25% of 6000 = 1500

Total valid votes = 4500

Ravikant gets 65%

So other candidate gets 35%

35% of 4500 = 1575

7. In a medical certificate, by mistake a candidate gave his height as 25% more than normal. In the interview panel, he clarified that his height was 5 feet 5 inches. Find the percentage correction made by the candidate from his stated height to his actual height.

- (a) 20 (b) 28.56
(c) 25 (d) None of these

Ans. (a)

Height increased = 25%

here $x = 25$ to reduce to normal % correction required is

$$= \frac{25}{100+25} \times 100 = 20\%$$

8. A number is mistakenly divided by 5 instead of being multiplied by 5. Find the percentage change in the result due to this mistake.

- (a) 96% (b) 95%
(c) 2400% (d) None of these

Ans. (a)

Let number is 100

It is divided by 5 we get 20

Now actual result should be $5 \times 100 = 500$

So % change is result

$$= \frac{500-20}{500} \times 100 = 96\%$$

9. Rajiv wanted to subtract 5 from a number. Unfortunately, he added 5 instead of subtracting. Find the percentage change in the result.

- (a) 300%
 (b) 66.66%
 (c) 50%
 (d) Cannot be determined

Ans. (d)

This cannot be determined because after adding or subtracting 5 to different numbers variable results are obtained.

10. In a mixture of 80 litres of milk and water, 25% of the mixture is milk. How much water should be added to the mixture so that milk becomes 20% of the mixture?
 (a) 20 litres (b) 15 litres
 (c) 25 litres (d) None of these

Ans. (a)

Total mixture 80 litre

Milk is 25% i.e. $\frac{25}{100} \times 80 = 20$ litre

to make it 20% amount of water required

to add = $\frac{60+x}{80+x} \times 100 = 80\%$

$$6000 + 100x = 6400 + 80x$$

$$20x = 400, x = 20$$

11. A landowner increased the length and the breadth of a rectangular plot by 10% and 20% respectively. Find the percentage change in the cost of the plot assuming land prices are uniform throughout his plot.
 (a) 33% (b) 35%
 (c) 22.22% (d) None of these

Ans. (d)

here $x = 10$ or $y = 20$

$$\% \text{ change in area} = \left(x + y + \frac{xy}{100} \right)$$

$$= 10 + 20 + \frac{10 \times 20}{100} = 32$$

12. The length, breadth and height of a room in the shape of a cuboid are increased by 10%, 20% and 50% respectively. Find the

percentage change in the volume of the cuboid.

- (a) 77% (b) 75%
 (c) 88% (d) 98%

Ans. (d)

Let l, b, h be length, breadth and height of the cuboid

$$\text{Volume } v = l.b.h$$

Now, l, b, h are increased by 10%, 20% 50% respectively

$$v = l \left[1 + \frac{10}{100} \right] \times b \left[1 + \frac{20}{100} \right] + h \left[1 + \frac{50}{100} \right]$$

$$= 1.98 l.b.h$$

$$\% \text{ change} = 98\%$$

13. The salary of Amit is 30% more than that of Varun. Find by what percentage is the salary of Varun less than that of Amit?
 (a) 26.12% (b) 23.07%
 (c) 21.23% (d) None of these

Ans. (b)

Let Varun's salary is 100

Amit salary = 30% more than Varun's Salary = 130 in % salary of Varun less than Amit

$$= \frac{30}{130} \times 100 = 23.07\%$$

14. The price of sugar is reduced by 25% but in spite of the decrease, Aayush ends up increasing his expenditure on sugar by 20%. What is the percentage change in his monthly consumption of sugar?
 (a) +60% (b) -10%
 (c) +33.33% (d) 50%

Ans. (a)

Let price of sugar be x & expenditure E

Now it is reduced by 25%. So it is $\frac{3}{4}x$ now expenditure of sugar is also increased by 20%

$$\text{i.e. } 1.2 E \text{ or } \frac{6}{5} E$$

25. A cow and a calf cost Rs. 2000 and Rs. 1400 respectively. If the price of the cow and that of the calf is increased by 20% and 30% respectively then the price of 1 dozen cows and 2 dozens calves is:

- (a) 72,480 (b) 71,360
 (c) 74,340 (d) None of these

Ans. (a)

Price of cow = Rs. 2000

Price of calf = 1400

Price of 1 dozen cow & 2 dozens calves at increased rate

$$= 12 \times \left(\frac{120}{100} \times 2000 \right) + 24 \times \left(\frac{130}{100} \times 1400 \right)$$

$$= 72480$$

26. Ram sells his goods 20% cheaper than Bobby and 20% dearer than Chandilya. How much percentage is Chandilya's goods cheaper/dearer than Bobby's.

- (a) 33.33% (b) 50%
 (c) 42.85% (d) None of these

Ans. (a)

Let Bobby's sale price is 100 Rs.

Ram sale price = 80 Rs.

Ram sale price is 20% dearer than Chandilya

So, Chandilya's price = CP

$$CP \times \frac{120}{100} = 80, CP = 66.66$$

Now Chandilya good is 33.33 Rs. cheaper than Bobby's i.e.

$$= \frac{33.63}{100} \times 100 = 33.33\%$$

27. During winters, an athlete can run 'x' metres on one bottle of Glucose. But in the summer, he can only run 0.5 x metres on one bottle of Glucose. How many bottles of Glucose are required to run 400 metres during summer?

- (a) $800/x$ (b) $890/x$
 (c) 96 (d) $454/x$

Ans. (a)

During summer to run – 5x one bottle of glucose is required

then to run 1 km $\frac{1}{0.5x}$ bottles

$$\therefore \text{to run 400m } \frac{1}{0.5x} \times 400 = \frac{800}{x} \text{ bottle}$$

28. Out of the total production of iron from hematite, an ore of iron, 20% of the ore gets wasted, and out of the remaining iron, only 25% is pure iron. If the pure iron obtained in a year from a mine of hematite was 80,000 kg, then the quantity of hematite mined from that mine in the year is

- (a) 5,00,000 kg (b) 4,00,000 kg
 (c) 4,50,000 kg (d) None of these

Ans. (b)

Let x kg ore is there

20% washed away so remaining is

80% i.e. $4/5$

out of $\frac{4}{5}$, 25% is pure iron $\frac{1}{5}x$

$\therefore \frac{1}{5}x$ kg is obtained from x kg

then 1 kg is obtained from 5 kg

\therefore 80000 kg is obtained from $5 \times 80000 = 400000$ kg

29. In an examination, 80% students passed in Physics, 70% in Chemistry while 15% failed in both the subjects. If 325 students passed in both the subjects. Find the total number of students who appeared in the examination.

- (a) 500 (b) 400
 (c) 300 (d) 600

Ans. (a)

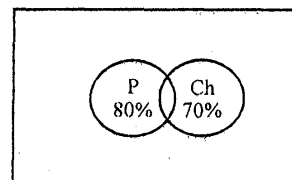

15% student failed in both subjects

So total passed = 85%

$80 + 70 = 85 + x$, $x = 65\%$

65% of total = 325

total = 500.

30. Ram spends 30% of his salary on house rent, 30% of the rest he spends on his children's education and 24% of the rest salary he spends on clothes. After his expenditure, he is left with Rs. 2500. What is Ram's salary?

- (a) Rs. 6713.2 (b) Rs. 20,000
(c) Rs. 10,000 (d) Rs. 15,000

Ans. (a)

Let total salary is x Rs.

30% on house rent = x

30% of remaining on Childrens education = y

24% of remaining on clothes = z

$$P \left[1 + \frac{x}{100} \right] \left[1 + \frac{y}{100} \right] \left[1 + \frac{z}{100} \right] = 2500$$

$$P \left[1 - \frac{30}{100} \right] \left[1 - \frac{30}{100} \right] \left[1 - \frac{24}{100} \right] = 2500$$

[(-)ve sign because of spending]

$$P \left[\frac{70}{100} \right] \left[\frac{70}{100} \right] \frac{76}{100} = 2500$$

$P = \text{Rs. } 6713.21$



Percentage



Practice Exercise: I

1. What percentage is equivalent to $5\frac{1}{4}$?
- (a) 525% (b) 425%
(c) 625% (d) None of these

2. $6\frac{2}{3}\%$ expressed as a fraction in its lowest term is

- (a) $\frac{2}{15}$ (b) $\frac{1}{15}$
(c) $\frac{3}{20}$ (d) None of these

3. What percent of 12 is 84?

- (a) 800% (b) 600%
(c) 700% (d) None of these

4. $37\frac{1}{2}\%$ of Rs. 48 is

- (a) Rs. 20 (b) Rs. 16
(c) Rs. 18 (d) None of these

5. 75% of 480 = (?) \times 15

- (a) 12 (b) 36
(c) 24 (d) None of these

6. If $37\frac{1}{2}\%$ of a number is 45, then $87\frac{1}{2}\%$ of the number will be

- (a) 115 (b) 135
(c) 105 (d) None of these

7. $x\%$ of $y + y\%$ of $x = ?$

- (a) 3% of xy (b) 2% of xy
(c) 5% of xy (d) None of these

8. $x\%$ of $y + ?\%$ of $x = x\%$ of $(x + y)$.

- (a) $x + y$ (b) x
(c) y (d) None of these

9. 25% of 25% = ?

- (a) 6.25 (b) 0.0625
(c) 0.625 (d) None of these

10. 20% of 30% of 20% of Rs. 850 is

- (a) Rs. 9.50 (b) Rs. 10.20
(c) Rs. 10.50 (d) None of these

11. 40% of 20% + 30% of 25% + 50% of 28% is equivalent to
 (a) 29.5% (b) 28.5%
 (c) 30.5% (d) None of these
12. If a number is 20% more than the other, how much percent is the second number less than the first?
 (a) $12\frac{1}{3}\%$ (b) $16\frac{2}{3}\%$
 (c) $16\frac{1}{3}\%$ (d) None of these
13. If the given two numbers are respectively 7% and 28% of a third number, then what percentage is the first of the second?
 (a) 20% (b) 25%
 (c) 18% (d) None of these
14. The price cooking oil has increased by 15%. The percentage of reduction that a family should effect in the use of cooking oil so as not to increase the expenditure on this account is
 (a) $15\frac{2}{23}\%$ (b) $13\frac{1}{23}\%$
 (c) $17\frac{1}{23}\%$ (d) None of these
15. A man's wages were decreased by 50%. Again, the reduced wages were increased by 50%. He has a loss of
 (a) 35% (b) 25%
 (c) 20% (d) None of these
16. The difference between a discount of 35% and two successive discounts of 20% and 20% on a certain bill was Rs. 22. Find the amount of the bill.
 (a) Rs. 3200 (b) Rs. 2200
 (c) Rs. 1800 (d) None of these
17. Two shopkeepers sell a radio of similar brand and type at the same list price of Rs. 1000. The first allows two successive discount of 20% and 10% and the second allows the successive discount of 15% and 15%. Find the difference in discounts offered by the two shopkeepers.
 (a) Rs. 3.50 (b) Rs. 1.50
 (c) Rs. 2.50 (d) None of these
18. The tax on a commodity is diminished by 10% and its consumption increases by 10%. Find the effects on revenue.
 (a) 1% (b) 2%
 (c) 3% (d) None of these
19. The radius of a sphere is increased 10%. The surface area increases by
 (a) 21% (b) 31%
 (c) 41% (d) None of these
20. If the side of a square is increased by 30%, its area is increased by
 (a) 49% (b) 69%
 (c) 79% (d) None of these
21. In measuring the sides of a rectangle, one side is taken 10% in excess and the other 20% in deficit. Find the error percent in area calculated from the measurement.
 (a) 12% deficit (b) 10% deficit
 (c) 12% excess (d) None of these
22. Water tax is increased by 20% but its consumption is decreased by 20%. The increase or decrease in the expenditure is
 (a) 4% decrease (b) 4% increase
 (c) 8% decrease (d) 8% increase
23. The population of a city increases at the rate of 10% annually. Its present population is 90.51 lacs. The population 3 years ago was nearly.
 (a) 72 lacs (b) 68 lacs
 (c) 80 lacs (d) None of these

24. The value of a machine is Rs. 6250. It decreases by 10% during the first year, 20% during the second year and 30% during the third year. What will be the value of the machine after 3 years?
 (a) Rs. 2650 (b) Rs. 3050
 (c) Rs. 3150 (d) None of these
25. An army lost 10% its men in war, 10% of the remaining due to diseases and 10% of the rest were disabled. Thus, the strength was reduced to 729000 active men. Find the original strength.
 (a) 1000000 (b) 1200000
 (c) 1500000 (d) None of these
26. In an examination, 30% and 35% students respectively failed in History and Geography while 27% students failed in both the subjects. If the number of students passing the examination is 248, find the total number of students who appeared in the examination.
 (a) 425 (b) 380
 (c) 400 (d) None of these
27. In an examination, there were 2000 candidates, out of which 900 candidates were boys and rest were girls. If 32% of the boys 38% of the girls passed, then the total percentage of failed candidates is
 (a) 35.3% (b) 64.7%
 (c) 68.5% (d) 70%
28. If the price of gold increases by 30%, find by how much the quantity of ornaments must be reduced so that the expenditure may remain the same as before?
 (a) $27\frac{2}{3}\%$ (b) $23\frac{1}{13}\%$
 (c) 30% (d) 19%
29. The price of an article is cut by 20%. To restore it to its original price, the new price must be increased by
 (a) 20% (b) 22.5%
 (c) 25% (d) 40%
30. In a fraction, numerator is increased by 25% and the denominator is diminished by 10%. The new fraction obtained is $\frac{5}{9}$. The original fraction is
 (a) $\frac{2}{5}$ (b) $\frac{5}{9}$
 (c) $\frac{3}{5}$ (d) None of these

Solutions

1. Ans. (a)

$$5\frac{1}{4} = \frac{21}{4} = \frac{21}{4} \times 100 = 525\%$$

2. Ans. (b)

$$6\frac{2}{3}\% = \frac{\left(\frac{20}{3}\right)}{100} = \left(\frac{20}{3} \times \frac{1}{100}\right) = \frac{1}{15}$$

3. Ans. (c)

Let $x\%$ of 12 = 84

$$\Rightarrow \frac{x}{100} \times 12 = 84 \Rightarrow x = \frac{84 \times 100}{12} = 700.$$

\therefore 700% of 12 is 84.

4. Ans. (c)

$$37\frac{1}{2}\% \text{ of Rs. } 48 = 48 \times \frac{75}{2 \times 100} = \text{Rs. } 18.$$

5. Ans. (c)

Let 75% of 480 = $x \times 15$.

Then,

$$\frac{75}{100} \times 480 = 15x \text{ or } x = \frac{75 \times 480}{100 \times 15} = 24.$$

6. Ans. (c)

Let the number be x , then

$$37\frac{1}{2}\% \text{ of } x = 45 \Rightarrow \frac{75}{2} \times \frac{1}{100} \times x = 45$$

$$\text{or, } \frac{3}{8}x = 45 \Rightarrow x = \frac{45 \times 8}{3} = 120.$$

$$\therefore 87\frac{1}{2}\% \text{ of } 120 = \frac{175}{2} \times \frac{1}{100} \times 120 = 105.$$

7. Ans. (b)

$$x\% \text{ of } y + y\% \text{ of } x = \left(\frac{x}{100} \times y\right) + \left(\frac{y}{100} \times x\right)$$

$$= \frac{2}{100}xy = 2\% \text{ of } xy.$$

8. Ans. (b)

Let the missing figure be a .

We have,

$$\frac{x}{100} \times y + \frac{a}{100} \times x = \frac{x}{100} \times (x+y)$$

$$\Rightarrow xy + ax = x(x+y) \Rightarrow ax = x^2.$$

$$\therefore a = x$$

9. Ans. (b)

25% of 25%

$$= \frac{25}{100} \times \frac{25}{100} = \frac{625}{10000} = 0.0625.$$

10. Ans. (b)

20% and 30% of 20% of 850

$$= \frac{20}{100} \times \frac{30}{100} \times \frac{20}{100} \times 850 = \frac{1020}{100}$$

$$= \text{Rs. } 10.20$$

11. Ans. (a)

$$40\% \text{ of } 20\% = \frac{40}{100} \times \frac{20}{100} = \frac{8}{100} = 8\%$$

$$30\% \text{ of } 25\% = \frac{30}{100} \times \frac{25}{100} = \frac{75}{100} = 7.5\%$$

$$\text{and, } 50\% \text{ of } 28\% = \frac{50}{100} \times \frac{28}{100}$$

$$= \frac{14}{100} = 14\%$$

$$\therefore (40\% \text{ of } 20\% + 30\% \text{ of } 25\% + 50\% \text{ of } 28\%) \\ = 8\% + 7.5\% + 14\% = 29.5\%.$$

12. Ans. (b)

Here, $x = 20$

$$\therefore \text{Required answer} = \left(\frac{x}{100+x} \times 100\right)\%$$

$$= \left(\frac{20}{100+20} \times 100\right)\% = 16\frac{2}{3}\%.$$

13. Ans. (b)

Here, $l = 7$, and $m = 28$.

\therefore First number

$$= \frac{l}{m} \times 100\% \text{ of second number}$$

$$= \frac{7}{28} \times 100\% \text{ of second number}$$

Or 25% of second number.

14. Ans. (b)

Reduction in consumption

$$= \left(\frac{P}{100+P} \times 100\right)\%$$

$$= \left(\frac{15}{100+15} \times 100\right)\% \text{ or } 13\frac{1}{23}\%.$$

15. Ans. (b)

Here, $x = -50$ and $y = 50$.

\therefore The net % change in wages

$$= \left(x + y + \frac{xy}{100} \right) \%$$

$$= \left(-50 + 50 - \frac{50 \times 50}{100} \right) \% \text{ or } -25\%.$$

Since the sign is -ve, he has a loss of 25%.

16. Ans. (b)

The equivalent discount of two successive discounts of 20% and 20%.

$$= \left(x + y + \frac{xy}{100} \right) \%$$

$$= \left(-20 - 20 + \frac{20 \times 20}{100} \right) \% \text{ or } -36\%.$$

Given: 36% - 35% = Rs. 22.

∴ Amount of the bill = $22 \times 100 = \text{Rs. } 2200$.

17. Ans. (c)

The equivalent discount of two successive discounts of 20% and 10%

$$= \left(x + y + \frac{xy}{100} \right) \%$$

$$= \left(-20 - 10 + \frac{20 \times 10}{100} \right) \% \text{ or } 28\%$$

∴ Discount on the list price of radio offered by the first shopkeeper

$$= 28\% \text{ of } 1000 = \frac{28}{100} \times 1000 = \text{Rs. } 280.$$

Also, the equivalent discount of two successive discounts of 15% and 15%

$$= \left(x + y + \frac{xy}{100} \right) \%$$

$$= \left(-15 - 15 + \frac{15 \times 15}{100} \right) \% \text{ or } 27\frac{3}{4}\%$$

∴ Discount on the list price of radio offered by the second shopkeeper.

$$= 27\frac{3}{4}\% \text{ of } 1000 = \frac{111}{400} \times 1000$$

$$= \text{Rs. } 277.50$$

∴ Difference in discounts offered by the two shopkeepers = Rs. 280 - Rs. 277.50 = Rs. 2.50.

18. Ans. (a)

Since tax × consumption = revenue

∴ Net % change in revenue

$$= \left(x + y + \frac{xy}{100} \right) \%$$

$$= \left(-10 + 10 - \frac{10 \times 10}{100} \right) \%$$

(here $x = -10$ and $y = 10$) = -1%

∴ The revenue decreases by 1%.

19. Ans. (a)

Since $4\pi \times \text{radius} \times \text{radius} = \text{surface area}$

∴ Net % change in area

$$= \left(x + y + \frac{xy}{100} \right) \%$$

$$= \left(10 + 10 + \frac{10 \times 10}{100} \right) \% = 21\%.$$

20. Ans. (b)

Since side × side = area

∴ Net % change in area

$$= \left(x + y + \frac{xy}{100} \right) \%$$

$$= \left(30 + 30 + \frac{30 \times 30}{100} \right) \% = 69\%.$$

∴ The area is increased by 69%.

21. Ans. (a)

Since $\text{side}_1 \times \text{side}_2 = \text{area}$

∴ Error % in area = $\left(x + y + \frac{xy}{100} \right) \%$

$$= \left(10 - 20 - \frac{10 \times 20}{100}\right)\%$$

(Here, $x = 10$ and $y = -20$)

= -12%, i.e. 12% deficit.

22. Ans. (a)

Since tax \times consumption = expenditure

\therefore Net % change in expenditure

$$= \left(x + y + \frac{xy}{100}\right)\%$$

$$= \left(20 - 20 - \frac{20 \times 20}{100}\right)\% \quad [x=20 \& y=-20]$$

= -4%.

\therefore Expenditure decreases by 4%.

23. Ans. (b)

We have, $P = 90.51$, $r = 10\%$ and $n = 3$.

\therefore The population 3 years ago

$$= \frac{P}{\left(1 + \frac{r}{100}\right)^n} = \frac{90.51}{\left(1 + \frac{10}{100}\right)^3}$$

$$= \frac{9051}{100} \times \frac{100}{110} \times \frac{100}{110} \times \frac{100}{110} = 68 \text{ lacs.}$$

24. Ans. (c)

Here, $A = 6250$, $x = -10$, $y = -20$ and $z = -30$.

\therefore Value of the machine after 3 years

$$= A \left(1 + \frac{x}{100}\right) \left(1 + \frac{y}{100}\right) \left(1 + \frac{z}{100}\right)$$

$$= 6250 \left(1 - \frac{10}{100}\right) \left(1 - \frac{20}{100}\right) \left(1 - \frac{30}{100}\right)$$

$$= \frac{6250 \times 90 \times 80 \times 70}{100 \times 100 \times 100} = \text{Rs. } 3150.$$

25. Ans. (a)

Let A be the original strength.

$$\text{Then, } A \left(1 + \frac{x}{100}\right) \left(1 + \frac{y}{100}\right) \left(1 + \frac{z}{100}\right)$$

= 729000 (Given)

Here, $x = -10$, $y = -10$ and $z = -10$.

$$\therefore A \left(1 - \frac{10}{100}\right) \left(1 - \frac{10}{100}\right) \left(1 - \frac{10}{100}\right)$$

= 729000

$$\Rightarrow A = \frac{729000 \times 100 \times 100 \times 100}{90 \times 90 \times 90}$$

= 1000000 men.

26. Ans. (c)

Percentage of students passing the examination

$$= (100 - (30 + 35 - 27))\%$$

[here, $x = 30$, $y = 35$ and $z = 27$]

$$= 62(100 - 38)\% = 62\%.$$

Let the total number of students appearing in the examination be x .

Given: 62% of $x = 248$

$$\text{or, } \frac{62}{100} \times x = 248 \text{ or } x = \frac{248 \times 100}{62} = 400.$$

Therefore, 400 students appeared in the examination.

27. Ans. (b)

Boys = 900, Girls = 1100

Passed = (32% of 900) + (38% of 1100)

$$= 288 + 418 = 706$$

$$\text{Failed} = 2000 - 706 = 1294$$

$$\text{Failed \%} = \left(\frac{1294}{2000} \times 100\right)\% = 64.7\%$$

28. Ans. (b)

$$\text{Reduction} = \frac{30}{100 + 30} \times 100\% = 23\frac{1}{13}\%$$

29. Ans. (c)

New price must be increased by

$$\left(\frac{20}{100-20} \times 100\right)\% = 25\%.$$

30. Ans. (a)

Let the fraction be $\frac{x}{y}$

$$\text{Then, } \frac{x+0.25x}{y-0.10y} = \frac{5}{9}, \quad \frac{x(1.25)}{y(0.9)} = \frac{5}{9}$$

$$\frac{x}{y} = \frac{5}{9} \times \frac{90}{125}, \Rightarrow \frac{x}{y} = \frac{2}{5}$$

□□□□

Percentage



Practice Exercise: II

- What is 25% of 25% equal to?
 - 6.25
 - .625
 - .0625
 - .00625
- One fourth of one third of two fifth of a number is 15. What will be 40% of that number?
 - 120
 - 350
 - 270
 - 180
- What will be 160% of a number whose 200% is 140?
 - 200
 - 160
 - 140
 - 112
- If three fifth of a number is 40 more than 40% of the same number. What is the number?
 - 100
 - 150
 - 200
 - 400
- If X is 90% of Y. What percent of X is Y?
 - 101.1
 - 190
 - 90
 - 111.1
- $(x\% \text{ of } y + y\% \text{ of } x) = ?$
 - $x\%$ of y
 - $y\%$ of x
 - 2% of xy
 - $xy\%$ of 3
- If 90% of A = 30% of B and B = $x\%$ of A, then x is equal to:
 - 900
 - 300
 - 800
 - 600
- 40 quintals is what percent of 2 metric tonnes?
 - 20%
 - 2%
 - 200%
 - 150%
- A student has to secure 40% marks to pass. He gets 178 marks and fails by 22 marks. The maximum marks are:
 - 200
 - 500
 - 800
 - 1000
- Of the total amount received by Purna, 20% was spent on purchases and 5% of the remaining on transportation. If he is left with Rs. 1520, the initial amount was:
 - Rs. 2800
 - Rs. 2000
 - Rs. 2400
 - Rs. 1600
- The price of jute has been reduced by 20%. If the reduced price is Rs. 800 per quintal, the original price per quintal was
 - Rs. 900
 - Rs. 640
 - Rs. 960
 - Rs. 1000
- Amit has some apples, He sold 40% more than he are. If he sold 70 apples, how many did he eat?
 - 50
 - 90
 - 18
 - 42
- $\frac{5}{9}$ part of the population in a village are males. If 30% of the males are married, the percentage of unmarried females in the total population is:
 - 70%
 - 40%
 - $27\frac{7}{9}\%$
 - 20%

14. A school has only three classes which contain 40, 50 and 60 students respectively. The pass percentages of these classes are 10, 20 and 10 respectively. The pass percentage of the school is:
- (a) $13\frac{1}{3}$ (b) 15
(c) 20 (d) $16\frac{2}{3}$
15. 30% of A's salary is equal to 20% of $\frac{3}{5}$ th of B's salary. If B's salary is Rs. 2400, what is A's salary?
- (a) Rs. 1880 (b) Rs. 1000
(c) Rs. 960 (d) Rs. 2160
16. If $x\%$ of a is the same as $y\%$ of b , then $z\%$ of b is
- (a) $\frac{yz}{x}\%$ of a (b) $\frac{xy}{z}\%$ of a
(c) $\frac{xz}{y}\%$ of a (d) None of these
17. A's marks in Biology are 20 less than 25% of the total marks obtained by him in Biology, Maths and Drawing. If his marks in Drawing be 50, what are his marks in Maths?
- (a) 40 (b) 45
(c) 50 (d) Can't be determined
18. From a container having pure milk, 20% is replaced by water and the process is repeated thrice. At the end of the third operation, the milk is:
- (a) 40% pure (b) 50% pure
(c) 51.2% pure (d) 58.8% pure
19. The salaries of A and B together amount to Rs. 2000. A spends 95% of his salary and B, 85% of his. If now, their savings are same, what is A's salary?
- (a) Rs. 1500 (b) Rs. 1250
(c) Rs. 750 (d) Rs. 1600
20. 300 grams of sugar solution has 40% sugar in it. How much sugar should be added to make it 50% in the solution?
- (a) 10 gms (b) 40 gms
(c) 60 gms (d) 80 gms
21. The price of an article is cut by 20%. To restore it to the former value, the new price must be increased by
- (a) 20% (b) 25%
(c) $16\frac{2}{3}\%$ (d) 24%
22. In an examination, there are 3 papers of Mathematics of 100 marks each. A boy secures 60% in the first paper and 70% in the second paper. In order to secure 70% in the aggregate the percentage of marks he should secure in third paper will be:
- (a) 90% (b) 80%
(c) 75% (d) 70%
23. Two numbers are less than a third number by 30% and 37% respectively. How much percent is the second number less than the first?
- (a) 10% (b) 7%
(c) 4% (d) 3%
24. In an examination, A got 10% marks less than B, B got 25% marks more than C and C got 20% less than D. If A got 360 marks out of 500, the percentage of marks obtained by D was:
- (a) 70 (b) 75
(c) 80 (d) 85
25. If the numerator of a fraction be increased by 15% and its denominator be diminished by

- 8%, the value of the fraction $\frac{15}{16}$. The original fraction is
- (a) $\frac{3}{5}$ (b) $\frac{3}{4}$
 (c) $\frac{3}{7}$ (d) $\frac{2}{3}$
26. Arvind spends 75% of his income. His income is increased by 20% and he increased his expenditure by 10%. His savings are increased by:
 (a) 10% (b) 25%
 (c) $37\frac{1}{2}\%$ (d) 50%
27. In an examination, 35% candidates failed in one subject and 42% failed in another subject while 15% failed in both the subjects. If 2500 candidates appeared at the examination, how many passed in either subject but not in both?
 (a) 325 (b) 1175
 (c) 2125 (d) None of these
28. The boys and girls in a college are in the ratio 3 : 2. If 20% of the boys and 25% of the girls are adults, the percentage of students who are not adults is:
 (a) 58% (b) 67.5%
 (c) 78% (d) 82.5%
29. The price of sugar is increased by 20%. As a result, a family decreases its consumption by 25%. The expenditure of the family on sugar will be decreased by:
 (a) 10% (b) 5%
 (c) 14% (d) 15%
30. A building worth Rs. 133,100 is constructed on land worth Rs. 72,900. After how many years will the value of both be the same if land appreciates at 10% p.a. and building depreciates at 10% p.a.?
 (a) 2.5 (b) 2
 (c) 1.5 (d) 3
31. A reduction of 21% in the price of wheat enables a person to buy 10.5 kg more for Rs. 100. What is the reduced price per kg?
 (a) Rs. 2 (b) Rs. 2.25
 (c) Rs. 2.30 (d) Rs. 2.50
32. Salaries of A, B and C are in the ratio 1:2:3. Salary of B and C together is Rs. 6000. By what percent is salary of C more than that of A?
 (a) 300 (b) 600
 (c) 100 (d) 200
33. The length of a rectangle is increased by 60%. By what percent would the width have to be decreased to maintain the same area?
 (a) $37\frac{1}{2}\%$ (b) 60%
 (c) 75% (d) None
34. For a sphere of radius 10 cm, the numerical value of surface area is what percent of the numerical value of its volume?
 (a) 24% (b) 26.5%
 (c) 30% (d) 45%
35. A cricket team won 40% of the total number of matches it played during a year. If it lost 50% of the matches played and 20 matches were drawn, the total number of matches played by the team during the year was:
 (a) 200 (b) 100
 (c) 50 (d) 40

Solutions

1. Ans. (c)

$$25\% \text{ of } 25\% = \frac{25}{100} \times \frac{25}{100} = \frac{1}{16} = .0625.$$

2. Ans. (d)

$$\text{Let } \frac{1}{4} \times \frac{1}{3} \times \frac{2}{5} \times x = 15.$$

Then, $x = 15 \times 30 = 450$

Now, $40\% \text{ of } 450 = \frac{40}{100} \times 450 = 180.$

3. Ans. (d)

Let $200\% \text{ of } x = 140.$

Then, $\frac{200}{100} \times x = 140 \text{ or } x = 70.$

Now, $160\% \text{ of } 70 = \frac{160}{100} \times 70 = 112.$

4. Ans. (c)

$$\frac{3}{5}x - 40\% \text{ of } x = 40 \Rightarrow \frac{3}{5}x - \frac{40}{100}x = 40.$$

$$\text{or } \frac{3}{5}x - \frac{2}{5}x = 40 \text{ or } \frac{x}{5} = 40$$

$$\text{or } x = (40 \times 5) = 200.$$

5. Ans. (d)

$$X = \frac{90}{100}Y \Rightarrow X = \frac{9}{10}Y \Rightarrow Y = \frac{10}{9}X$$

$$\Rightarrow \frac{Y}{X} = \frac{10}{9}.$$

\therefore Required percentage

$$= \left(\frac{Y}{X} \times 100 \right) = \left(\frac{10}{9} \times 100 \right) \% = 111.1.$$

6. Ans. (c)

$$\frac{x}{100}y + \frac{y}{100}x = \frac{2xy}{100} = 2\% \text{ of } xy.$$

7. Ans. (b)

$$\frac{90}{100}A = \frac{30}{100}B \Rightarrow B = \frac{90}{100} \times \frac{100}{30}A$$

$$= \frac{300}{100}A = 300\% \text{ of } A.$$

$$\therefore x = 300$$

8. Ans. (c)

Note that 1 metric tonne = 10 quintals.

\therefore Required percentage

$$= \left(\frac{40}{2 \times 10} \times 100 \right) \% = 200\%$$

9. Ans. (b)

$$40\% \text{ of } x = 178 + 22$$

$$\text{or } \frac{40}{100}x = 200 \text{ or } x = \left(200 \times \frac{100}{40} \right) = 500.$$

10. Ans. (b)

$$\text{Purchases} = 20\% \text{ of } x = \frac{x}{5}.$$

$$\text{Balance} = x - \frac{x}{5} = \frac{4x}{5}.$$

Transportation = 5% of

$$\frac{4x}{5} = \frac{5}{100} \times \frac{4x}{5} = \frac{x}{25}.$$

$$\text{Balance} = \frac{4x}{5} - \frac{x}{25} = \frac{19x}{25}.$$

$$\therefore \frac{19x}{25} = 1520 \Rightarrow x = \frac{1520 \times 25}{19} = 2000.$$

11. Ans. (d)

$$80\% \text{ of } x = 800 \Rightarrow \frac{80}{100}x = 800$$

$$\Rightarrow x = 800 \times \frac{100}{80} = 1000.$$

12. Ans. (a)

Suppose he ate x apples.

Then, apples sold = 140% of

$$x = \left(\frac{140}{100} \times x \right) = \frac{7x}{5}.$$

$$\frac{7x}{5} = 70 \Rightarrow x = 70 \times \frac{5}{7} = 50.$$

13. Ans. (c)

Let, total population = x . Males = $\frac{5}{9}x$.

Married males = 30% of

$$\frac{5}{9}x = \frac{30}{100} \times \frac{5}{9}x = \frac{x}{6}$$

Married females = $\frac{x}{6}$.

$$\text{Total females} = \left(x - \frac{5}{9}x\right) = \frac{4x}{9}$$

$$\text{Unmarried females} = \left(\frac{4x}{9} - \frac{x}{6}\right) = \frac{5x}{18}$$

∴ Required percentage

$$= \left(\frac{5x}{18} \times \frac{1}{x} \times 100\right)\% = 27\frac{7}{9}\%$$

14. Ans. (a)

Number of passed candidates

$$= \left(\frac{10}{100} \times 40 + \frac{20}{100} \times 50 + \frac{10}{100} \times 60\right)$$

$$= (4 + 10 + 6) = 20$$

$$\text{Passed percentage} = \frac{20}{(40 + 50 + 60)} \times 100$$

$$= \left(\frac{20}{150} \times 100\right)\% = 13\frac{1}{3}\%$$

15. Ans. (c)

$$30\% A = 20\% \text{ of } \frac{3}{5}B \Rightarrow \frac{30A}{100} = \frac{20}{100} \times \frac{3}{5}B$$

$$\therefore A = \frac{20}{100} \times \frac{3}{5} \times \frac{100}{30} B = \frac{2}{5}B$$

$$= \left(\frac{2}{5} \times 2400\right) = 960.$$

16. Ans. (c)

$$x\% \text{ of } a = y\% \text{ of } b \Rightarrow \frac{x}{100}a = \frac{y}{100}b \Rightarrow b$$

$$= \left(\frac{x}{100} \times \frac{100}{y}\right)a = \left(\frac{x}{y}\right)a$$

$$\therefore z\% \text{ of } b = \left(z\% \text{ of } \frac{x}{y}\right)a$$

$$= \left(\frac{xz}{y \times 100}\right)a = \left(\frac{xz}{y}\right)\% \text{ of } a.$$

17. Ans. (d)

Let $B + M + D = x$.

Then, $B = (25\% \text{ of } x - 20)$

$$= \left(\frac{25}{100}x - 20\right) = \left(\frac{x}{4} - 20\right) \& D = 50$$

$$\therefore \frac{x}{4} - 20 + M + 50 = x \text{ or } M = \left(\frac{3x}{4} - 30\right)$$

So, marks in Maths cannot be determined.

18. Ans. (c)

Let total quantity of original milk = 1000 gm.

Milk after first operation

$$= 80\% \text{ of } 1000 = 800 \text{ gm.}$$

Milk after second operation

$$= 80\% \text{ of } 800 = 640 \text{ gm.}$$

Milk after third operation

$$= 80\% \text{ of } 640 = 512 \text{ gm.}$$

∴ Strength of final mixture = 51.2%.

19. Ans. (a)

Let A's salary = x . Then, B's = $(2000 - x)$

5% of A = 15% of B, i.e.

$$\frac{5}{100}x = \frac{15}{100}(2000 - x) \text{ or } x = 1500.$$

20. Ans. (c)

$$\text{Sugar} = \left(\frac{40}{100} \times 300\right) \text{ gms} = 120 \text{ gms,}$$

water = 180 gms.

Let x gm sugar may be added.

$$\begin{aligned} \text{Then, } \frac{120+x}{300+x} \times 100 = 50 &\Rightarrow 240 + 2x \\ &= 300 + x \Rightarrow x = 60 \end{aligned}$$

21. Ans. (b)

Let original price = 100. New price = 80.

Increase on 80 = 20

$$\text{Increase on 100} = \left(\frac{20}{80} \times 100 \right) \% = 25\%.$$

22. Ans. (b)

$$60 + 70 + x = \frac{70}{100} \times 300 \text{ or } x = 80\%.$$

23. Ans. (a)

Let, third number be x . Then,

$$\text{First number} = 70\% \text{ of } x = \frac{7x}{10}$$

$$\text{Second number} = 63\% \text{ of } x = \frac{63x}{100}$$

Required Percentage

$$= \left(\frac{7x}{100} \times \frac{10}{7x} \times 100 \right) \% = 10\%.$$

24. Ans. (c)

$$A = \frac{90}{100}B, B = \frac{125}{100}C \text{ and } C = \frac{80}{100}D.$$

$$\therefore B = \frac{10}{9}A, C = \frac{4}{5}B \text{ and } D = \frac{5}{4}C.$$

$$B = \frac{10}{9} \times 360 = 400, C = \frac{4}{5} \times 400 = 320$$

$$\& D = \frac{5}{4} \times 320 = 400.$$

$$\text{Percentage of } D = \left(\frac{400}{500} \times 100 \right) \% = 80\%.$$

25. Ans. (b)

Let the given fraction be x/y .

$$\text{Then, } \frac{115\% \text{ of } x}{92\% \text{ of } y} = \frac{15}{16} \Rightarrow \frac{115x}{92y} = \frac{15}{16}$$

$$\Rightarrow \frac{x}{y} = \left(\frac{15}{16} \times \frac{92}{115} \right) = \frac{3}{4}.$$

26. Ans. (d)

Let income = 100, Expenditure = 75 &

Savings = 25.

New income = 120, New expenditure

$$= \left(\frac{110}{100} \times 75 \right) = \frac{165}{2}.$$

$$\text{New savings} = \left(120 - \frac{165}{2} \right) = \frac{75}{2}.$$

$$\text{Increase in savings} = \left(\frac{75}{2} - 25 \right) = \frac{25}{2}.$$

Increase percent

$$= \left(\frac{25}{2} \times \frac{1}{25} \times 100 \right) \% = 50\%.$$

27. Ans. (b)

$$\text{Failed in 1st subject} = \left(\frac{35}{100} \times 2500 \right) = 875.$$

$$\text{Failed in 2nd subject} = \left(\frac{42}{100} \times 2500 \right) = 1050.$$

$$\text{Failed in both} = \left(\frac{15}{100} \times 2500 \right) = 375.$$

$$\text{Failed in 1st subject only} = (875 - 375) = 500.$$

$$\text{Failed in 2nd subject only} = (1050 - 375) = 675.$$

Passed in 2nd only + Passed in 1st only

$$= (675 + 500) = 1175.$$

28. Ans. (c)

Suppose boys = $3x$ and girls = $2x$.

$$\text{Not adults} = \left(\frac{80}{100} \times 3x \right) + \left(\frac{75}{100} \times 2x \right)$$

$$= \left(\frac{12x}{5} + \frac{3x}{2} \right) = \frac{39x}{10}$$

Required percentage

$$= \left(\frac{39x}{10} \times \frac{1}{5x} \times 100 \right) \% = 78\%$$

29. Ans. (a)

Let original consumption = 100 units & original price = Rs. 100/unit.

Original expenditure = Rs. (100 × 100)
= Rs. 10000.

New expenditure = Rs. (120 × 75) = Rs. 9000.

∴ Decrease in expenditure

$$= \left(\frac{1000}{10000} \times 100 \right) \% = 10\%$$

30. Ans. (d)

$$72900 \left(1 + \frac{10}{100} \right)^n = 133100 \times \left(1 - \frac{10}{100} \right)^n$$

$$\therefore \left(\frac{11}{10} \right)^n \times \left(\frac{10}{9} \right)^n = \frac{133100}{72900} = \frac{1331}{729}$$

$$\therefore \left(\frac{11}{9} \right)^n = \left(\frac{11}{9} \right)^3 \quad \Rightarrow n = 3$$

31. Ans. (a)

Let original price = Rs. x /kg. Reduced price

$$= \left(\frac{79}{100} x \right) / \text{kg.}$$

$$\frac{100}{79x} - \frac{100}{x} = 10.5 \Rightarrow \frac{10000}{79x} - \frac{100}{x} = 10.5$$

$$10000 - 7900 = 10.5 \times 79x$$

$$\text{or } x = \frac{2100}{10.5 \times 79}$$

∴ Reduced price

$$= \text{Rs.} \left(\frac{79}{100} \times \frac{2100}{10.5 \times 79} \right) / \text{kg} = \text{Rs.} 2 / \text{kg}$$

32. Ans. (d)

Let $A = x$, $B = 2x$ and $C = 3x$,

Then, $2x + 3x = 6000 \Rightarrow x = 1200$.

∴ $A = 1200$ and $C = 3600$.

Required excess

$$= \left(\frac{2400}{1200} \times 100 \right) \% = 200\%$$

33. Ans. (a)

Let length = l and breadth = b .

Let the required decrease in breadth be $x\%$.

$$\text{Then, } \frac{160}{100} l \times \frac{(100-x)}{100} \times b = lb$$

$$\Rightarrow 160(100-x) = 100 \times 100$$

$$\text{or } 100-x = \frac{10000}{160} = \frac{125}{2}$$

$$\Rightarrow x = \left(100 - \frac{125}{2} \right) = 37\frac{1}{2}$$

34. Ans. (c)

$$\text{Surface area } 4\pi R^2 = \frac{3}{R} \left(\frac{4}{3} \pi R^3 \right)$$

$$= \frac{3}{R} \times \text{Volume}$$

When $R = 10$, we have

$$S = \frac{3}{10} V = \left(\frac{3}{10} \times 100 \right) \% \text{ of } V = 30\% \text{ of } V.$$

35. Ans. (a)

$$40\% \text{ of } x + 50\% \text{ of } x + 20 = x$$

$$\Rightarrow \frac{40}{100} x + \frac{50}{100} x + 20 = x \quad \text{or } x = 200.$$

□□□□



Profit and Loss

Profit and loss are part and parcel of every commercial transaction. In fact, the entire economy and concept of capitalism is based on the so called 'profit and loss'.

Business transactions have now-a-days become common feature of life. When a person deals in purchase and sale of any item, he either gains or loses some amount generally. The aim of entire business is to earn profit.

The commonly used term in dealing with questions involving sales and purchase are:

Cost Price

The cost price of an article is the price at which an article has been purchased. It is abbreviated as C.P.

Selling Price

The selling price of an article is the price at which an article has been sold - It is abbreviated as S. P.

Profit or Gain

If the selling price of an article is more than the cost price, there is a gain or profit.

$$\text{Thus, Profit or Gain} = \text{S.P.} - \text{C.P.}$$

Loss

If the cost price of an article is greater than the selling price, the seller suffers a loss.

$$\text{Thus, Loss} = \text{C.P.} - \text{S.P.}$$

Profit and loss are always calculated with the respect to the cost price of the item

$$\text{Profit\%} = \frac{\text{Profit}}{\text{C.P.}} \times 100$$

$$\text{Loss\%} = \frac{\text{Loss}}{\text{C.P.}} \times 100$$

Example:

By selling an article at 500 Rs. Mohan incurs 50Rs. gain then find cost price of that article

$$\text{C.P.} = \text{SP} - \text{Gain}$$

$$\text{C.P.} = 500 - 50$$

$$= 450 \text{ Rs.}$$

Example:

Ramesh purchased a radioset at Rs. 1500 and sold it at Rs. 1200. Find loss incurred by him?

$$\text{Loss} = \text{C.P.} - \text{SP}$$

$$= 1500 - 1200 = 300.$$

Also in this case we can calculate

$$\text{Loss\%} = \frac{300}{1500} \times 100 = 20\%$$

Thus he incurred 20% loss.

Basic Formulae

1. When SP and Gain% are Given then

$$CP = \left(\frac{100}{100 + \text{Gain}\%} \right) \times \text{S.P.}$$

2. When the C.P. and Gain % are given then

$$\text{S.P.} = \frac{100 + \text{Gain}\%}{100} \times \text{C.P.}$$

3. When C.P. and loss% are given then

$$\text{SP} = \frac{100 - \text{Loss}\%}{100} \times \text{C.P.}$$

4. When S.P. and loss percentages are given

$$CP = \left(\frac{100}{100 - \text{Loss}\%} \right) \times 100$$

5. If the cost price (C.P.) of
- m
- articles is equal to selling price of
- n
- article, then

$$\% \text{ gain or loss} = \left[\frac{m-n}{n} \right] \times 100$$

If $m > n$, it is % gain and if $m < n$, it is % loss

Example: If the S.P. of 12 articles is equal to the cost price of 18 articles, what is profit%?

Solution:

Here $m=18, n=12$

$$\text{Profit \%} = \frac{(m-n)}{n} \times 100$$

$$= \frac{18-12}{12} \times 100 = \frac{6}{12} \times 100 = 50\%$$

Example: If the S. P. of a dozen apple is equal to cost price of 9 apples find gain or loss%?

Solution:

Here $m=9, n=12$

$$\Rightarrow \left(\frac{m-n}{n} \right) \times 100 = \frac{9-12}{12} \times 100$$

$$= \frac{1}{4} \times 100 = -25\%$$

(-ve) sign indicates loss.

6. When two different articles are sold at the same S.P., getting gain/loss of
- $x\%$
- on the first and gain/loss of
- $y\%$
- on the second, the overall % gain or % loss in the transaction is given by

$$\left[\frac{100(x+y) + 2xy}{(100+x) + (100+y)} \right] \%$$

The above expression represent overall gain or loss according to its given (+)ve or (-ve).

7. When two different articles are sold at the same selling price getting gain of
- $x\%$
- on the first and loss of
- $x\%$
- on the second, then the overall % loss in the transaction is given by

$$\left(\frac{x}{10} \right)^2 \%$$

Example: Michael sold two T.V. sets for Rs. 3600 each gaining 20% on one and loosing 20% on the other. Find the total gain or loss percent.

Solution:

Here $x = 20$

$$\text{So, overall loss} \left(\frac{x}{10} \right)^2 \% = \left(\frac{20}{10} \right)^2 \% = 4\%$$

8. A merchant uses faulty measure and sells his goods at gain/loss of
- $x\%$
- . The overall % gain or loss (g) is given by

$$\frac{100+g}{100+x} = \frac{\text{True measure}}{\text{Faulty measure}}$$

Note: If merchant sells his goods at cost price then $x = 0$.

Example: A dishonest shopkeeper professes to sell his goods at the cost price but use faulty measure. His 1 kg weight measures 950 gms only. Find his gain percent.

Solution:

Here, True measure = 1000 gms

False measure = 950 gms

Since the Shopkeeper sells the goods at cost price.

$\therefore x = 0$,

\therefore overall gain % is given by

$$\frac{\text{True measure}}{\text{Faulty measure}} = \frac{100+g}{100+x}$$

$$\Rightarrow \frac{1000}{950} = \frac{1000+g}{1000}$$

$$\text{So, } 100 + g = \frac{1000 \times 100}{950}, \quad g = 5\frac{5}{19}\%$$

Discount

9. If two successive discount of an article are $m\%$ and $n\%$ respectively, then a single discount equivalent to the successive

discount will be $\left(m+n-\frac{mn}{100}\right)\%$

It can also be calculated as

$$\left[100 - 100 \times \frac{(100-m)}{100} \times \frac{(100-n)}{100}\right]\%$$

Example 1: Two successive discount of 10% and 20% is equal to a single discount of

$$\left(10+20-\frac{10 \times 20}{100}\right) = 28\%$$

Which is less than 30%.

□□□□

Ex.1 Find the single discount which is equivalent to a successive discounts of 50% and 40%.

Sol.: Single discount will be equal to

$$\left(m+n-\frac{mn}{100}\right)\%$$

$$\Rightarrow \left(50+40-\frac{50 \times 40}{100}\right)\%$$

$$\Rightarrow 70\%$$

Ex.2 Find the single discount which is equal to three successive discounts of 10%, 20% and 30%.

Sol.: Here first of all we will determine the single discount, which is equal to two successive discounts of 10% and 20%.

$$\Rightarrow \left[10+20-\frac{10 \times 20}{100}\right]\%$$

$$\Rightarrow 28\%$$

Now, we will find a single discount which is equal to two successive discounts of 28% and 30%

$$\Rightarrow \left[28+30-\frac{28 \times 30}{100}\right]\%$$

$$\Rightarrow 49.6\% \text{ Ans.}$$

Ex.3 Find a single discount which is equivalent to three successive discounts of 50%, 40% and 20%.

Sol.: Single Discount equivalent to 50% and 40% is equal to

$$\Rightarrow \left[50+40-\frac{50 \times 40}{100}\right]\%$$

$$\Rightarrow 70\% \text{ Ans.}$$

Now, we will find single discount which is equal to two successive discounts of 70% & 20%.

$$\Rightarrow \left[70 + 20 - \frac{70 \times 20}{100} \right] \%$$

$$\Rightarrow 76\% \text{ Ans.}$$

Ex.4 Find a single discount which is equivalent to three successive discounts of 20%, 30% and 20%.

Sol.: Single discount equivalent to 20% and 30% is

$$\Rightarrow \left[20 + 30 - \frac{20 \times 30}{100} \right] \%$$

$$\Rightarrow 44\%$$

Now, we will find single discount which is equivalent to two successive discounts of 44% and 20%.

$$\Rightarrow \left[44 + 20 - \frac{44 \times 20}{100} \right] \%$$

$$\Rightarrow 55.2\%$$

□□□□



Solved Examples

1. By selling a watch for Rs. 495, a shopkeeper incurs a loss of 10%. Find the cost price of the watch for the shopkeeper.

- (a) Rs. 545 (b) Rs. 550
(c) Rs. 555 (d) None of these

Ans. (b)

Here S.P. = 495

Loss = 10%

$$\text{C.P.} = \frac{\text{SP}}{(100 - \text{Loss}\%)} \times 100$$

$$\text{CP} = \frac{495}{90} \times 100 = 550 \text{ Rs.}$$

2. By selling a cap for Rs. 34.40, a man gains 7.5% percent. What will be the CP of the cap?

- (a) Rs. 32.80 (b) Rs. 32
(c) Rs. 32.40 (d) Rs. 28.80

Ans. (b)

$$\text{C.P.} = \frac{\text{SP}}{(100 + \text{Gain}\%)} \times 100$$

$$\Rightarrow \frac{34.40}{107.5} \times 100 = 32$$

3. A shopkeeper sold goods for Rs. 2400 and made a profit of 25% in the process. Find his profit percent if he had sold his goods for Rs. 2040.

- (a) 6.25% (b) 7%
(c) 6.20% (d) 6.5%

Ans. (a)

SP = 2400, Profit% = 25

$$\text{C.P.} = \frac{\text{SP}}{(100 + \text{P}\%)} \times 100 = \frac{2400}{125} \times 100 = 1920$$

If sold at 2040, profit = 120 Rs.

$$\text{Profit \%} = \frac{120}{1920} \times 100 = 6.25$$

4. A digital diary is sold for Rs. 935 at a profit of 10%. What would have been the actual profit or loss on it, if it had been sold for Rs. 810?

- (a) Rs. 45 (b) Rs. 40
(c) Rs. 48 (d) Rs. 50

Ans. (b)

SP = 935, Profit % = 10%

$$\text{CP} = \frac{935}{110} \times 100 = 850$$

Diary if sold at 810, Loss = 40 Rs.

5. By selling bouquets for Rs. 63, a florist gains 5%. At what price should he sell the bouquets to gain 10% on the cost price?

- (a) Rs. 66 (b) Rs. 69
(c) Rs. 72 (d) Rs. 72.50

- Ans. (a)** SP = 63, Profit % = 5
 $CP = \frac{63}{105} \times 100 = 60$ Rs.
 So, to gain 10% it should be sold at 66 Rs.
6. A shopkeeper bought 240 chocolates at Rs. 9 per dozen. If he sold all of them at Re. 1 each, what was his profit percent?
 (a) 66(1/6)% (b) 33(1/3)% (c) 24% (d) 27%
- Ans. (b)**
 CP of 12 chocolate = 9 Rs.
 CP of 1 chocolate = $\frac{9}{12} = 75$ Rs.
 Now SP = 1 Rs. Profit = 0.25 Rs.
 Profit % = $\frac{0.25}{75} \times 100 = 33\frac{1}{3}\%$
7. A coal merchant makes a profit of 20% by selling coal at Rs. 25 per quintal. If he sells the coal at Rs. 22.50 per quintal, what is his profit percent on the whole investment?
 (a) 6% (b) 6.66% (c) 7.5% (d) 8%
- Ans. (d)**
 Profit % = 20%, SP = 25
 $CP = \frac{25}{125} \times 100 = \frac{6}{125}$ Rs. = 20.83
 Profit if SP = 22.50
 $= 22.50 - 20.83 = 1.667$
 Profit % = $\frac{1.667}{20.83} \times 100 = 8\%$
 [in fractional term this can be solved very easily]
8. The cost price of a shirt and trouser is Rs. 371. If the shirt costs 12% more than the trousers, find the cost price of the trouser.
 (a) Rs. 125 (b) Rs. 150 (c) Rs. 175 (d) Rs. 200

- Ans. (c)**
 Let CP of trouser be x Rs.
 Now CP of shirt = $\frac{112x}{100}$ Rs.
 According to given condition
 $x + \frac{112x}{100} = 371, \frac{100}{212}x = 371, x = 175$ Rs.
9. A pet shop owner sells two puppies at the same price. On one he makes a profit of 20% and on the other he suffers a loss of 20%. Find his loss or gain percent on the whole transaction.
 (a) Gain of 4% (b) No profit no loss (c) Loss of 10% (d) Loss of 4%
- Ans. (d)**
 In such cases we always incur loss and loss percentage
 $= \left[\frac{x}{20} \right]^2 = \left[\frac{10}{20} \right]^2 = 4\%$
10. The marked price of a table is Rs. 1200, which is 20% above the cost price. It is sold at a discount of 10% on the marked price. Find the profit percent.
 (a) 10% (b) 8% (c) 7.5% (d) 6%
- Ans. (b)**
 MP = 1200
 CP = $\frac{1200}{120} \times 100 = 1000$
 If sold at 10% discount
 S.P. = $1200 \times \frac{100}{90} = 1080$
 Profit on CP = 80 Rs.
 Profit % = $\frac{80}{1000} \times 100 = 8\%$

11. A dozen pairs of gloves quoted at Rs. 80 are available at a discount of 10%. Find how many pairs of gloves can be bought for Rs. 24.

- (a) 4 (b) 5
(c) 6 (d) 8

Ans. (a)

12 pairs of gloves are available at 80 Rs. (with 10% discount) $80 \times \frac{90}{100} = 72$ Rs.

∴ In 72 Rs. 12 pairs are available then in

$$1 \text{ Re } \frac{12}{72} \text{ pairs}$$

$$\therefore \text{ In 24 Rs. } \frac{12}{72} \times 24 = 4$$

12. Find a single discount equivalent to the discount series of 20%, 10%, 5%.

- (a) 30% (b) 31.6%
(c) 68.4% (d) 35%

Ans. (b)

Single discount

$$\left\{ 100 - \left(100 \times \frac{80}{100} \times \frac{90}{100} \times \frac{95}{100} \right) \right\} \% \\ = 100 - 68.4 = 31.6\%$$

13. How much percent more than the cost price should a shopkeeper mark his goods, so that after allowing a discount of 12.5% he should have a gain of 5% on his outlay?

- (a) 9.375 (b) 16.66%
(c) 20% (d) 25%

Ans. (c)

Let the cost price be x Rs. and printed price be y Rs.

Hence, price after giving a discount of 12.5%

$$= y - y \times \frac{12.5}{100}$$

$$\text{Given, } = y - y \times \frac{12.5}{100} = x + x \times \frac{5}{100}$$

$$\Rightarrow y \times \frac{87.5}{100} = x + x \times \frac{105}{100}$$

$$\therefore y = \frac{105}{87.5} x \Rightarrow y - x = \frac{105}{87.5} x - x = \frac{17.5}{87.5} x$$

Required Percentage

$$= \frac{y - x}{x} \times 100 = \frac{17.5}{87.5} \times 100 = 20\%$$

14. In order to maintain the price line, a trader allows a discount of 10% on the marked price of goods in his shop. However, he still makes a gross profit of 17% on the cost price. Find the profit percent he would have made on the selling price had he sold at the marked price.

- (a) 23.07 (b) 30%
(c) 21.21% (d) 25%

Ans. (b)

Let the cost price be x Rs. and marked price be y Rs.

$$\text{Given, } y - y \times \frac{10}{100} = x + x \times \frac{17}{100}$$

$$\Rightarrow y \times \frac{90}{100} = x + x \times \frac{117}{100} \Rightarrow y = \frac{117}{90} x$$

$$\therefore y - x = \frac{27}{90} x$$

∴ Required profit percent

$$= \frac{y - x}{x} \times 100 = \frac{27}{90} \times 100 = 30\%$$

15. A whole-seller allows a discount of 20% on the list price to a retailer. The retailer sells at 5% discount on the list price. If the customer paid Rs. 38 for an article, what profit is made by the retailer?

- (a) Rs. 10 (b) Rs. 8
(c) Rs. 6 (d) None of these

Ans. (c)

Let the list price be x Rs.

$$\text{Then, } x - x \times \frac{5}{100} = 38$$

$$\Rightarrow x \times \frac{95}{100} = 38, \therefore x = 40 \text{ Rs.}$$

The buying price for the retailer

$$= 40 - 40 \times \frac{20}{100} = 32 \text{ Rs.}$$

Hence profit made by retailer

$$= 38 - 32 = 6 \text{ Rs.}$$

16. The cost of production of a cordless phone set in 2002 is Rs. 900, divided between material, labour and overheads in the ratio 3 : 4 : 2. If the cordless phone set is marked at a price that gives a 20% profit on the component of price accounted for by labour, what is the marked price of the set?

- (a) Rs. 980 (b) Rs. 1080
(c) Rs. 960 (d) None of these

Ans. (a)

Cost of phone accounted for by labour

$$= \frac{4}{3+4+2} \times 900 = 400 \text{ Rs.}$$

Component of price accounted for by labour

$$= 400 + 400 \times \frac{20}{100} = 480 \text{ Rs.}$$

Marked price of the set

$$= 480 + (900 - 400) = 980 \text{ Rs.}$$

17. If subsequently in 2003, the cost of material, labour and overheads increased by 20%, 30% and 10% respectively, calculate the cost of manufacturing in 2003.

- (a) Rs. 1150 (b) Rs. 1050
(c) Rs. 1080 (d) Rs. 1100

Ans. (d)

In 2003, cost of material

$$= 300 + 300 \times \frac{20}{100} = 360 \text{ Rs.}$$

Cost of labour

$$= 400 + 400 \times \frac{30}{100} = 520 \text{ Rs.}$$

Cost of overhead

$$= 200 + 200 \times \frac{10}{100} = 220 \text{ Rs.}$$

Hence, cost of manufacturing

$$= 360 + 520 + 220 = 1100 \text{ Rs.}$$

18. The cost price of 50 mangoes is equal to the selling price of 40 mangoes. Find the percentage profit?

- (a) 20% (b) 25%
(c) 30% (d) None of these

Ans. (b)

Let the cost price of each mango be Rs. 1

Then cost price of 40 mangoes = 40 Rs.

Selling price of 40 mangoes = 50 Rs.

\therefore Percentage profit

$$= \frac{50 - 40}{40} \times 100 = 25\%$$

19. A owns a house worth Rs. 10,000. He sells it to B at a profit of 15%. After some time, B sells it back to A at 15% loss. Find A's loss or gain percent.

- (a) 2.25% gain (b) 6.25% gain
(c) 17.64% gain (d) 17.25% gain

Ans. (d)

Buying price of the House by B

$$= 10000 + 10000 \times \frac{15}{100} = 11500 \text{ Rs.}$$

Price at which A buys house from B.

$$= 11500 - 11500 \times \frac{15}{100} = 11500 - 1725$$

$$= 9775 \text{ Rs.}$$

Hence A's gain percent

$$= \frac{11500 - 9775}{10000} \times 100 = 17.25\%$$

20. Anil bought an article at Rs. 200 and sold it at a profit of 10%. What would have been the increase in the profit percent if it was sold for Rs. 230?

- (a) 5% (b) 10%
 (c) 15% (d) None of these

Ans. (a)

Amount of profit when article is sold at profit of 10%

$$= 200 \times \frac{10}{100} = 20 \text{ Rs.}$$

Amount of profit when article is sold for Rs. 230. = 230 - 200 = 30 Rs.

Hence, increase in profit percent

$$= \frac{30 - 20}{200} \times 100 = 5\%$$

21. A reduction of 10% in the price of sugar enables a housewife to buy 6.2 kg more for Rs. 279. Find the reduced price per kilogram.

- (a) Rs. 5 (b) Rs. 4.5
 (c) Rs. 4.05 (d) None of these

Ans. (b)

Let original rate = Rs. x per kg

New rate = 90% of

$$x = \text{Rs.} \left(\frac{90}{100} x \right) = \text{Rs.} \frac{9x}{10}$$

$$\text{Original quantity for Rs. 279} = \frac{279}{x}$$

$$\text{New quantity} = 279 \times \frac{10}{9x} = \frac{310}{x}$$

$$\therefore \frac{310}{x} - \frac{279}{x} = 6.2 \Rightarrow \frac{31}{x} = 6.2$$

$$\Rightarrow x = \frac{31}{6.2} = 5$$

$$\therefore \text{Reduced Price} = \frac{9 \times 5}{10} = \text{Rs.} 4.5 \text{ per kg}$$

22. If the cost price of 30 article is equal to the selling price of 20 article, find the profit percent.

- (a) 33.33% (b) 40%
 (c) 50% (d) 60%

Ans. (c)

Let the cost price of 1 article is 1 Rs.

Cost price of 20 articles = 20 Rs.

Selling price of 20 article = 30 Rs.

$$\therefore \text{Profit percent} = \frac{30 - 20}{20} \times 100 = 50\%$$

23. A shopkeeper sells sugar in such a way that the selling price of 950 gm is the same as the cost price of one kilogram. Find his gain percent.

- (a) 100/17% (b) 150/17%
 (c) 5(5/19)% (d) 1/19%

Ans. (c)

Let the cost price of 1 gm. is 1 Rs.

Then cost price of 950 gm = 950 Rs.

Selling price of 950 gm = 1000 Rs.

Hence, gain percent

$$= \frac{1000 - 950}{950} \times 100$$

$$= \frac{50}{950} \times 100 = 5\frac{5}{19}\%$$

24. A dealer sold two TV sets for Rs. 2400 each, gaining 20% on one and losing 20% on the other set. Find his net gain or net loss.

- (a) Rs. 300 loss (b) Rs. 200 loss
 (c) Rs. 200 gain (d) Rs. 300 gain

Ans. (b)

Selling price of two TV sets

$$= 2400 + 2400 = 4800 \text{ Rs.}$$

Cost price of two TV sets

$$= \frac{100}{120} \times 2400 + \frac{100}{80} \times 2400$$

$$= 2000 + 3000 = 5000 \text{ Rs.}$$

$$\therefore \text{Net loss} = 5000 - 4800 = 200 \text{ Rs.}$$

25. A man sells an article at 5% above its cost price. If he had bought it at 5% less than what he paid for it and sold it for Rs. 2 less, he would have gained 10%. Find the cost price of the article.

- (a) Rs. 500 (b) Rs. 360
(d) Rs. 425 (d) Rs. 400

Ans. (d)

Let the cost price of the article = x Rs.

Price when it is bought at 5% less than cost price

$$= x - x \times \frac{5}{100} = \frac{95}{100}x$$

Selling price when it is sold for Rs. 2 less.

$$= x + x \times \frac{5}{100} - 2 = \frac{105}{100}x - 2$$

$$\text{Given, } \frac{105}{100}x - 2 - \frac{95}{100}x = \frac{95}{100}x \times \frac{10}{100}$$

$$\Rightarrow \frac{10}{100}x - 2 = \frac{95}{1000}x$$

$$\therefore x = \frac{2 \times 1000}{5} = 400 \text{ Rs.}$$

26. A briefcase was sold at a profit of 10%. If its cost price was 5% less and it was sold for Rs. 7 more, the gain would have been 20%. Find the cost price of the briefcase.
(a) Rs. 175 (b) Rs. 200
(c) Rs. 225 (d) Rs. 160

Ans. (a)

Let the cost price = x Rs.

$$\text{Price 5% less than cost price} = \frac{95}{100}x$$

Selling price when sold for Rs. 7 more

$$= \frac{110}{100}x + 7$$

$$\text{Given, } \frac{110}{100}x + 7 - \frac{95}{100}x = \frac{95x}{100} \times \frac{20}{100}$$

$$\Rightarrow \frac{20}{500}x = 7 \quad \therefore x = \frac{7 \times 500}{20} = 175 \text{ Rs.}$$

27. A man sells a plot of land at 6% profit. If he had sold it at 10% profit, he would have

received Rs. 200 more. What is the selling price of the land?

- (a) Rs. 5000 (b) Rs. 5300
(c) Rs. 4800 (d) Rs. 5500

Ans. (b)

Let the cost price of land = x Rs.

$$\text{Given, } x + x \times \frac{10}{100} = x + x \times \frac{6}{100} + 200$$

$$\Rightarrow x + \frac{4x}{100} = 200$$

$$\Rightarrow x = \frac{100 \times 200}{4} = 5000 \text{ Rs.}$$

Selling price of land

$$5000 + 5000 \times \frac{6}{100} = 5300 \text{ Rs.}$$

28. A man buys two cycles for a total cost of Rs. 900. By selling one for $\frac{4}{5}$ of its cost and other for $\frac{5}{4}$ of its cost, he makes a profit of Rs. 90 on the whole transaction. Find the cost price of lower priced cycle.
(a) Rs. 360 (b) Rs. 250
(c) Rs. 300 (d) Rs. 420

Ans. (c)

Let the cost of the two cycles be x and y Rs.

$$\text{Then, } x + y = 900 \quad \dots(i)$$

$$\text{Again, } \frac{4x}{5} + \frac{5y}{4} - 900 = 90$$

$$\Rightarrow \frac{4x}{5} + \frac{5y}{4} = 990 \quad \dots(ii)$$

Solving (i) & (ii), we get

$$x = 300, y = 600.$$

29. A trader purchases apples at Rs. 60 per hundred. He spends 15% on the transportation. What should be the selling price per 100 to earn a profit of 20%.
(a) Rs. 72 (b) Rs. 81.8
(c) Rs. 82.8 (d) Rs. 83.8

Ans. (c)

Cost of 100 apples after transportation

$$= 60 + 60 \times \frac{15}{100} = 69 \text{ Rs.}$$

Selling price per 100 apples to earn a profit of 20%

$$= 69 + 69 \times \frac{20}{100} = 82.8 \text{ Rs.}$$

30. A dishonest dealer professes to sell at cost price but uses a 900 gram weight instead of a 1 kilogram weight. Find the percent profit to the dealer.

- (a) 10% (b) 11.11%
(c) 12.5% (d) None of these

Ans. (b)

Let the cost price be x Rs. per kg.

Then cost price of 900 gm = $\frac{9}{10}x$

Hence % profit

$$= \frac{x - \frac{9}{10}x}{\frac{9}{10}x} \times 100 = \frac{100}{9}\% = 11.11\%$$



Profit & Loss



Practice Exercise: I

- Cost of 3 cricket balls = cost of 2 pairs of leg pads.
Cost of 3 pairs of leg pads = cost of 2 pairs of gloves.
Cost of 3 pairs of gloves = cost of 2 cricket bats.
If a cricket bat costs Rs. 54, what is the cost of a cricket ball?
(a) Rs. 12 (b) Rs. 14
(c) Rs. 16 (d) Rs. 18
- What is the loss percent if a man loses Rs. 10 on selling an article for Rs. 100?
(a) $9\frac{1}{11}\%$ (b) 10%
(c) $11\frac{1}{9}\%$ (d) None
- When a commodity is sold for Rs. 34.80, there is a loss of 25%. What is the cost price of the commodity?
(a) Rs. 46.40 (b) Rs. 26.10
(c) Rs. 43 (d) Rs. 43.20
- A retailer buys a radio for Rs. 225. His overhead expenses are Rs. 15. He sells the radio for Rs. 300. The profit percent of the retailer is:
(a) 10 (b) 25
(c) 50 (d) 52
- There would be 10% loss if a toy is sold at Rs. 10.80 per piece. At what price should it be sold to earn a profit of 20%?
(a) Rs. 12 (b) Rs. 12.96
(c) Rs. 14.40 (d) None
- If books bought at prices ranging from Rs. 200 to Rs. 350 are sold at prices ranging from Rs. 300 to Rs. 425, what is the greatest possible profit that might be made in selling eight books?
(a) Rs. 400
(b) Rs. 600
(c) Cannot be determined
(d) None of these
- The cost price of 20 articles is the same as selling price of 15 articles. The profit percent in the transaction is:
(a) 25 (b) 30
(c) $33\frac{1}{3}$ (d) 50

8. If the selling price of 18 articles is equal to the C.P. of 21 articles, the loss or gain percent is:
- (a) $16\frac{2}{3}\%$ gain (b) $14\frac{2}{7}\%$ gain
(c) $16\frac{2}{3}\%$ loss (d) $14\frac{2}{7}\%$ loss
9. A man sold 250 chairs and had a gain equal to selling price of 50 chairs. His profit percent is:
- (a) 5% (b) 10%
(c) 25% (d) 50%
10. A vendor loses the S.P. of 4 oranges on selling 36 oranges. His loss percent is:
- (a) $12\frac{1}{2}\%$ (b) $11\frac{1}{9}\%$
(c) 10% (d) None of these
11. A shopkeeper, on selling a pen for Rs. 10, loses $\frac{1}{11}$ of what it costs him. His cost price is:
- (a) Rs. 9 (b) Rs. 10
(c) Rs. 11 (d) Rs. 12
12. If I purchased 11 books for Rs 10 and sold all the books at the rate of 10 books for Rs. 11, the profit percent is:
- (a) 10% (b) 11%
(c) 21% (d) 100%
13. Ajay bought 15 kg of dal at the rate of Rs.14.50 per kg and 10 kg at the rate of Rs.13 per kg. He mixed the two and sold the mixture at the rate of Rs. 15 per kg. What was his total gain in this transaction?
- (a) Rs. 1.10 (b) Rs. 16.50
(c) Rs. 11 (d) Rs. 27.50
14. Pure ghee costs Rs. 100 per kg. After adulterating it with vegetable oil costing Rs. 50 per kg, a shopkeeper sells the mixture at the rate of Rs. 96 per kg, thereby making a profit of 20%. In what ratio does he mix the two?
- (a) 1 : 2 (b) 3 : 2
(c) 3 : 1 (d) None of these
15. A dealer professing to sell his goods at cost price, uses a 900 gm weight for a kilogram. His gain percent is:
- (a) 9 (b) 10
(c) 11 (d) $11\frac{1}{9}$
16. Toffees are bought at the rate of 3 for a rupee. To gain 50%, they must be sold at:
- (a) 2 for a rupees (b) 1 for a rupees
(c) 4 for a rupee (d) 5 for a rupees
17. By selling 45 lemons for Rs. 40, a man loses 20%. How many should he sell for Rs. 24 to gain 20% in the transaction?
- (a) 16 (b) 18
(c) 20 (d) 22
18. A man gains 10% by selling a certain article for a certain price. If he sells it at double the price, the profit made is:
- (a) 20% (b) 120%
(c) 100% (d) 140%
19. A sells a bicycle to B at a profit of 20% and B sells it to C at a profit of 25%. If C pays Rs. 1500, what did A pay for it?
- (a) Rs. 825 (b) Rs. 1000
(c) Rs. 1100 (d) Rs. 1125
20. If the manufacturer gains 10%, the wholesale dealer 15% and the retailer 25%, then the cost of production of a table, the retail price of which is Rs. 1265 was:
- (a) Rs. 632.50 (b) Rs. 800
(c) Rs. 814 (d) Rs. 834.34
21. Two mixers and one T.V. cost Rs. 7000, while two T.V.'s and a mixer cost Rs. 9800. The value of one T.V. is:
- (a) Rs. 2800 (b) Rs. 2100
(c) Rs. 4200 (d) Rs. 8400

22. A horse and a cow were sold for Rs. 12000 each. The horse was sold at a loss of 20% and the cow at a gain of 20%. The entire transaction resulted in:
- (a) no loss or no gain
 (b) loss of Rs. 1000
 (c) gain of Rs. 1000
 (d) gain of Rs. 2000
23. An Article is sold at a certain price. By selling it at $\frac{2}{3}$ of that price one loses 10%. The gain percent at original price is:
- (a) 20% (b) $33\frac{1}{3}\%$
 (c) 35% (d) 40%
24. A grocer sells rice at a profit of 10% and uses weights which are 20% less than the market weight. The total gain earned by him will be:
- (a) 30% (b) 35%
 (c) 37.5% (d) None of these
25. Two-third of a consignment was sold at a profit of 5% and the remainder at a loss of 2%. If the total profit was Rs. 400, the value of the consignment (in rupees) was:
- (a) 20000 (b) 15000
 (c) 12000 (d) 10000
26. A fruit seller has 24 kg of apples. He sells a part of these at 20% gain and the balance at a loss of 5%. If on the whole he earns a profit of 10%, the amount of apples sold at loss is:
- (a) 6 kg (b) 4.6 kg
 (c) 9.6 kg (d) 11.4 kg
27. The C. P. of an article is 40% of the S. P. The percent that the S.P. is of C.P. is:
- (a) 250 (b) 240
 (c) 60 (d) 40
28. If an article is sold at 5% gain instead of 5% loss, the seller gets Rs. 6.72 more. The C.P. of the article is:
- (a) Rs. 67.20 (b) Rs. 120
 (c) Rs. 134.40 (d) Rs. 240
29. A man bought an article and sold it at a gain of 5%. If he had bought it at 5% less and sold it for Re 1 less, he would have made a profit of 10%. The C.P. of the article was:
- (a) Rs. 100 (b) Rs. 150
 (c) Rs. 200 (d) Rs. 500
30. A reduction of 25% in the price of eggs will enable one to buy 4 dozen more eggs for Rs. 96. What is the price per dozen?
- (a) Rs. 6 (b) Rs. 8
 (c) Rs. 8.50 (d) Rs. 9
31. Raghu bought 4 dozen oranges at Rs. 12 per dozen and 2 dozen oranges at Rs. 16 per dozen. He sold them all to earn 20% profit. At what price per dozen did he sell the oranges?
- (a) Rs. 14.40 (b) Rs. 16
 (c) Rs. 16.80 (d) Rs. 19.20
32. The profit earned by selling an article for Rs. 900 is double the loss incurred when the same article is sold for Rs. 450. At what price should the article be sold to make 25% profit?
- (a) Rs. 600 (b) Rs. 750
 (c) Rs. 800 (d) Data inadequate
33. A man sold an article for Rs. 75 and lost something. Had he sold it for Rs. 96, his gain would have been double the former loss. The C.P. of the article is:
- (a) Rs. 81 (b) Rs. 82
 (c) Rs. 83 (d) Rs. 85.50
34. A single discount equivalent to a discount series of 30%, 20% and 10% is:
- (a) 50% (b) 49.6%
 (c) 49.4% (d) 51%

35. A table is offered for Rs. 300 with 20% and 10% off. If in addition, a discount of 5% is offered on cash payment, then the cash price of the table is:

- (a) Rs. 240 (b) Rs. 216
(c) Rs. 210 (d) Rs. 205.20

36. A tradesman marks his goods 30% above the C.P. If he allows a discount of $6\frac{1}{4}\%$, then his gain percent is:

- (a) $23\frac{3}{4}\%$ (b) 22%
(c) $21\frac{7}{8}\%$ (d) None

37. The difference between a discount of 40% on Rs. 500 and two successive discount of 36% and 4% on the same amount is:

- (a) Nil (b) Rs. 2
(c) Rs. 7.20 (d) Rs. 1.93

38. What price should a shopkeeper mark on an article, costing him Rs. 153, to gain 20% after allowing a discount of 15%?

- (a) Rs. 224 (b) Rs. 216
(c) Rs. 184 (d) Rs. 162

39. If the S.P. of Rs. 24 results in a 20% discount on list price, what S.P. would result in a 30% discount on list price?

- (a) Rs. 27 (b) Rs. 21
(c) Rs. 20 (d) Rs. 9

40. A shopkeeper earns a profit of 12% on selling a book at 10% discount on the printed price. The ratio of the cost price to the printed price of the book is:

- (a) 50 : 61 (b) 45 : 56
(c) 99 : 125 (d) 55 : 69

41. A retailer buys 30 articles from a wholesaler at the price of 27. If he sells this at their marked price, the gain percent in the transaction is :

- (a) $9\frac{1}{11}\%$ (b) 10%
(c) $11\frac{1}{9}\%$ (d) $16\frac{2}{3}\%$

42. A cloth merchant announces 25% rebate in prices. If one needs to have a rebate of Rs. 40, then how many shirts each costing Rs. 32, he should purchase?

- (a) 5 (b) 6
(c) 7 (d) 10

43. A shopkeeper professes to sell all things at a discount of 10%, but increase the S.P. of each article by 20%. His gain on each article is:

- (a) 6% (b) 8%
(c) 10% (d) 12%

Solutions

1. Ans. (c)

$$3G = 54 \times 2 = 108 \Rightarrow G = 36.$$

$$3P = 36 \times 2 = 72 \Rightarrow P = 24$$

$$3C = 24 \times 2 = 48 \Rightarrow C = 16$$

\therefore Cost of a cricket ball = Rs. 16.

2. Ans. (d)

S.P.=Rs. 100, loss= Rs. 10. So,

$$C.P. = \left(\frac{100}{90} \times 100 \right) = \text{Rs. } \frac{1000}{9}.$$

$$\therefore \text{Loss\%} = \left(10 \times \frac{9}{1000} \times 100 \right) \% = 9\%.$$

3. Ans. (a)

S.P.=Rs. 34.80, Loss = 25%.

$$C.P. = \text{Rs. } \left(\frac{100}{75} \times 34.80 \right) = \text{Rs. } 46.40$$

4. Ans. (b)

C.P.=Rs.(225+15)=Rs. 240, S.P.=Rs. 300

$$\therefore \text{Gain \%} = \left(\frac{60}{240} \times 100 \right) \% = 25\%$$

5. Ans. (c)

$$90 : 10.80 = 120 : x \text{ or } \frac{90}{10.80} = \frac{120}{x}$$

$$\therefore x = \frac{120 \times 10.80}{90} = 14.40$$

Hence, S.P. = Rs. 14.40

6. Ans. (d)

Least C.P. = Rs. (200 × 8) = Rs. 1600.

Greatest S.P. = Rs. (425 × 8) = Rs. 3400.

Required profit = Rs. (3400 - 1600)
= Rs. 1800.

7. Ans. (c)

Let C.P. of each article be Re 1.

C.P. of 15 articles = Rs. 15

S.P. of 15 articles = Rs. 20.

$$\therefore \text{Gain \%} = \left(\frac{5}{15} \times 100 \right) \% = 33\frac{1}{3}\%$$

8. Ans. (c)

Let C.P. of each article be Re 1.

C.P. of 18 articles = Rs. 18.

S.P. of 18 articles = Rs. 21.

$$\therefore \text{Gain \%} = \left(\frac{3}{18} \times 100 \right) \% = 16\frac{2}{3}\%$$

9. Ans. (c)

Gain = (S.P. of 250 chairs) - (C.P. of 250 chairs).

$$\therefore (\text{S.P. of 250 chairs}) - (\text{C.P. of 250 chairs}) \\ = \text{S.P. of 50 chairs.}$$

S.P. of 200 chairs = C.P. of 250 chairs.

Let C.P. of each chair be Re. 1

C.P. of 200 chairs = Rs. 200.

S.P. of 200 chairs = Rs. 250.

$$\text{Gain \%} = \left(\frac{50}{200} \times 100 \right) \% = 25\%$$

10. Ans. (c)

(C.P. of 36) - (S.P. of 36) = Loss = S.P. of 4.

 \therefore S.P. of 40 = C.P. of 36

Let C.P. of each mango = Re 1

C.P. of 40 mangoes = Rs. 40

S.P. of 40 mangoes = Rs. 36

$$\text{Loss \%} = \left(\frac{4}{40} \times 100 \right) \% = 10\%$$

11. Ans. (c)

$$\text{Loss} = (\text{C.P.} - \text{S.P.}) \Leftrightarrow \frac{1}{11} \text{C.P.} = \text{C.P.} - 10$$

$$\Leftrightarrow \frac{10}{11} \text{C.P.} = 10$$

$$\therefore \text{C.P.} = \left(\frac{11 \times 10}{10} \right) = \text{Rs. 11}$$

12. Ans. (c)

Suppose, the number of books purchased
= 11 × 10 = 110

$$\text{C.P. of 110 books} = \text{Rs.} \left(\frac{10}{11} \times 110 \right) \\ = \text{Rs. 100}$$

$$\text{S.P. of 110 books} = \text{Rs.} \left(\frac{11}{10} \times 110 \right) \\ = \text{Rs. 121, Profit \%} = 21\%$$

13. Ans. (d)

C.P. of 25 kg = Rs. (15 × 14.50 + 10 × 13)
= Rs. 347.50

S.P. of 25 kg = Rs. (25 × 15) = Rs. 375.

 \therefore Gain = Rs. (375 - 347.50) = Rs. 27.50

14. Ans. (b)

$$\text{Mean price} = \text{Rs.} \left(\frac{100}{120} \times 96 \right) = \text{Rs. 80/kg.}$$

By the rule of alligation:

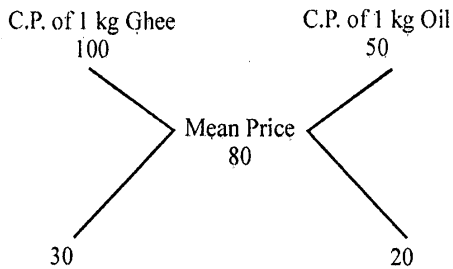

∴ Required ratio = 30 : 20 = 3 : 2.

15. Ans. (d)

$$\text{Gain \%} = \left(\frac{100}{900} \times 100 \right) \% = 11\frac{1}{9}\%$$

16. Ans. (a)

C. P. of 3 toffees = Re. 1

S. P. of 3 toffees = 150% of Re 1 = Rs. $\frac{3}{2}$

For Rs. $\frac{3}{2}$, toffees sold = 3.

For Re 1, toffees sold = $\left(3 \times \frac{2}{3} \right) = 2$.

17. Ans. (b)

Let S.P. of 45 lemons be Rs. x

$$80 : 40 = 120 : x \text{ or } \frac{80}{40} = \frac{120}{x}$$

$$\text{or } x = \frac{40 \times 120}{80} = 60$$

For Rs. 60, lemons sold = 45

For Rs. 24,

$$\text{lemons sold} = \left(\frac{45}{60} \times 24 \right) = 18.$$

18. Ans. (b)

$$110 : x = (100 + P) : 2x \text{ or}$$

$$\frac{110}{x} = \frac{100 + p}{2x} \text{ or } 100 + P = 220$$

$$\therefore p = 120\%.$$

19. Ans. (b)

125% of 120% of

$$A = 1500 \Rightarrow \frac{125}{100} \times \frac{120}{100} A = 1500$$

$$\therefore A = \left(1500 \times \frac{2}{3} \right) = 1000$$

20. Ans. (b)

125% of 115% of 110% of $p = 1265$.

$$\therefore \frac{125}{100} \times \frac{115}{100} \times \frac{110}{100} p = 1265$$

$$\text{or } \frac{253}{160} p = 1265.$$

$$\therefore p = \left(\frac{1265 \times 160}{253} \right) = \text{Rs. } 800$$

21. Ans. (c)

Let C.P. of a mixer be Rs. x and that of a T.V. be Rs. y .

Then, $2x + y = 7000$ and $2y + x = 9800$.

Multiplying 2nd equation by 2 and subtracting first from it, we get

$$3y = 19600 - 7000 = 12600 \text{ or } y = 4200$$

∴ C. P. of a T. V. = Rs. 4200

22. Ans. (b)

Total S. P. = Rs. 24000

C. P. of horse

$$= \text{Rs.} \left(\frac{100}{80} \times 12000 \right) = \text{Rs. } 15000.$$

C. P. of a cow

$$= \text{Rs.} \left(\frac{100}{120} \times 12000 \right) = \text{Rs. } 10000.$$

Total C.P. = Rs. 25000.

$$\therefore \text{Loss} = 24000 - 25000 = \text{Rs. } 1000$$

23. Ans. (c)

Let original S. P. be Rs. x ,New S.P. = $\frac{2}{3}x$, loss = 10%

$$\therefore \text{C.P.} = \left(\frac{100}{90} \times \frac{2}{3}x \right) = \frac{20x}{27}$$

New, C.P. = $\frac{20x}{27}$, S.P. = Rs. x ,

$$\text{Gain} = \left(x - \frac{20x}{27} \right) = \frac{7x}{27}$$

$$\therefore \text{Gain\%} = \left(\frac{7x}{27} \times \frac{27}{20x} \times 100 \right) \% = 35\%$$

24. Ans. (c)

Let us consider a packet of rice marked 1 kg.

Its actual weight is 80% of 1000 gm = 800 gm.

Let C.P. of each gm be Re. 1.

Then, C. P. of this packet = Rs. 800.

S. P. of this packet = 110% of C.P. of 1 kg.

$$= \left(\frac{110}{100} \times 1000 \right) = \text{Rs. } 1100$$

$$\therefore \text{Gain} = \left(\frac{300}{800} \times 100 \right) \% = 37.5\%$$

25. Ans. (b)

Let the total value be Rs. x Value of $\frac{2}{3}$ rd = $\frac{2x}{3}$, Value of $\frac{1}{3}$ rd = $\frac{x}{3}$.

$$\text{Total S. P.} = \left(105\% \text{ of } \frac{2x}{3} + 98\% \text{ of } \frac{x}{3} \right)$$

$$= \left(\frac{210x}{300} + \frac{98x}{300} \right) = \frac{308x}{300}$$

$$\frac{308x}{300} - x = 400 \Rightarrow \frac{308x - 300x}{300} = 400$$

$$\therefore x = \frac{300 \times 400}{8} = 15000$$

26. Ans. (c)

Suppose, the quantity sold at a loss be x kg and let C.P. per kg be Re. 1

Total C. P. = Rs. 24.

Total S. P. = 120% of $(24 - x)$ + 95% of x .

$$= \frac{6}{5}(24 - x) + \frac{19x}{20} = \frac{576 - 24x + 19x}{20}$$

$$= \frac{576 - 5x}{20}$$

$$\therefore \frac{576 - 5x}{20} = 110\% \text{ of } 24$$

$$\text{or } \frac{576 - 5x}{20} = \frac{264}{10}$$

$$\text{or } 576 - 5x = 528 \text{ or } 5x = 48$$

$$\text{or } x = 9.6 \text{ kg}$$

27. Ans. (a)

$$\text{C.P.} = \frac{40}{100} \times \text{S.P. ie. S.P.} = \frac{5}{2} \text{C.P.}$$

$$= \left(\frac{5}{2} \times 100 \right) \% \text{ of C.P.}$$

$$\therefore \text{S.P.} = 250\% \text{ of C.P.}$$

28. Ans. (a)

Let C.P. be Rs. x

$$(105\% \text{ of } x) - (95\% \text{ of } x) = 6.72$$

$$\text{or } 10\% \text{ of } x = 6.72.$$

29. Ans. (c)

Let original C.P. be Rs. x Its

$$\text{S.P.} = \frac{105}{100}x = \frac{21x}{20}$$

$$\text{New C.P.} = \frac{95}{100}x = \frac{19x}{20}$$

$$\text{New S.P.} = \frac{110}{100} \times \frac{19x}{20} = \frac{209x}{200}$$

$$\frac{21x}{20} - \frac{209x}{200} = 1 \text{ or } x = 200$$

30. Ans. (b)

Let original price per dozen be Rs. x

$$\text{New price per dozen} = \frac{75x}{100} = \frac{3x}{4}$$

$$\text{Now, } 96 \times \frac{4}{3x} - \frac{96}{x} = 4$$

$$\text{or } (128 - 96) = 4x \text{ or } x = 8.$$

31. Ans. (b)

$$\text{Total C.P.} = \text{Rs. } (12 \times 4 + 16 \times 2) = \text{Rs. } 80.$$

S. P. of 6 dozen oranges

$$= \text{Rs. } \left(\frac{120}{100} \times 80 \right) = \text{Rs. } 96.$$

S. P. per dozen = Rs. 16

32. Ans. (b)

Let C.P. be Rs. x

$$900 - x = 2(x - 450) \Rightarrow 3x = 1800 \Rightarrow x = 600.$$

C.P. = Rs. 600, gain required = 25%.

$$\therefore \text{S.P.} = \text{Rs. } \left(\frac{125}{100} \times 600 \right) = \text{Rs. } 750$$

33. Ans. (b)

Let C.P. be Rs. x .

$$2(x - 75) = (96 - x) \Rightarrow 3x = 246 \Rightarrow x = 82.$$

34. Ans. (b)

Let marked price be Rs. 100.

Then, S. P. = 90% of 80% of 70% of 100

$$= \left(\frac{90}{100} \times \frac{80}{100} \times \frac{70}{100} \times 100 \right) = 50.4$$

\therefore Single discount = $(100 - 50.4)\% = 49.6\%$

35. Ans. (d)

Cash price = 95% of 90% of 80% of Rs. 300.

$$= \left(\frac{95}{100} \times \frac{90}{100} \times \frac{80}{100} \times 300 \right) = \text{Rs. } 205.20$$

36. Ans. (c)

Let C.P. be Rs. 100. Then, marked price = Rs. 130.

$$\text{S.P.} = \left(100 - \frac{25}{4} \right) \% \text{ of Rs. } 130$$

$$= \left(\frac{375}{400} \times 130 \right) = 121.875$$

$$\therefore \text{Profit}\% = 21.875 = \frac{21875}{1000} = 21\frac{7}{8}\%$$

37. Ans. (c)

1st discount = Rs. (40% of 500)

$$= \text{Rs. } \left(\frac{40}{100} \times 500 \right) = \text{Rs. } 200$$

2nd discount = (36% of 500 + 4% of 64% of 500).

$$= \text{Rs. } \left(\frac{36}{100} \times 500 + \frac{4}{100} \times \frac{64}{100} \times 500 \right)$$

= Rs. 192.80

Difference = Rs. (200 - 192.80) = Rs. 7.20.

38. Ans. (b)

C.P. = Rs. 153, Gain = 20%.

$$\therefore \text{S.P.} = \left(\frac{120}{100} \times 153 \right) = \text{Rs. } 183.60$$

Let, the marked price be Rs. x

$$\frac{85}{100}x = 183.60$$

$$\Rightarrow x = \frac{183.60 \times 100}{85} = 216$$

39. Ans. (b)

Let, the list price be Rs. x

$$\frac{80}{100}x = 24 \Rightarrow x = \frac{24 \times 100}{80} = 30$$

Required S.P. = 70% of Rs.30 = Rs. 21

40. Ans. (b)

Let the C.P. be Rs. 100.

Then, S.P. = Rs. 112.

Let the printed price be Rs. x

$$\text{Then, } 90\% \text{ of } x = 112 \Rightarrow \frac{90}{100}x = 112$$

$$\therefore x = \left(\frac{112 \times 100}{90} \right) = \frac{1120}{9}$$

$$\therefore (\text{C.P.}) : (\text{Printed price}) = 100 : \frac{1120}{9}$$

$$= 900 : 1120 = 45 : 56$$

41. Ans. (c)

Let the C.P. of each article be Re. 1.

Then, C.P. of 30 = Rs.27, S.P. of 30 = Rs.30

$$\therefore \text{Gain\%} = \left(\frac{3}{27} \times 100 \right) \% = 11\frac{1}{9}\%$$

42. Ans. (a)

Rs. 25 is the rebate on Rs. 100

Rs. 40 will be the rebate on

$$\text{Rs. } \left(\frac{100}{25} \times 40 \right) = \text{Rs. } 160$$

 \therefore Number of shirts purchased

$$= \frac{160}{32} = 5$$

43. Ans. (b)

Let C. P. be Rs. 100. Then, marked price = Rs. 120

$$\text{S.P.} = 108 = 120 \left(\frac{90}{100} \right)$$

$$\therefore \text{S.P.} = \text{Rs.} \left(\frac{90}{100} \times 120 \right) = \text{Rs. } 108$$

 \therefore Gain = 8%

□□□□



Simple Interest & Compound Interest

Simple Interest

It is calculated on the basis of a basic amount borrowed for the entire period at a particular rate of interest.

The amount borrowed is the principal for the entire period of borrowing.

$$SI = \frac{P \times R \times T}{100}$$

Where P is principal amount

R is % rate of interest

T is the time duration

Compound Interest

The interest of the previous years are added to the principal for the calculation of the compound interest.

$$C.I. = P \left[1 + \frac{R}{100} \right]^T - P$$

Where P is principal amount

R is Rate of interest

T is time duration

Case1: When interest is compounded annually then amount A will be

$$A = \left[1 + \frac{R}{100} \right]^T$$

Case2: When interest is compounded half yearly then

$$A = \left[1 + \frac{R/2}{100} \right]^{2T}$$

Case3: When interest is compounded quarterly

$$A = \left[1 + \frac{R/4}{100} \right]^{4T}$$

Case 4: When differential rate of interest is charged i.e. if rate of interest is

R1% for first year.

R2% for second year and

R3% for third year then

Amount

$$= P \left[1 + \frac{R_1}{100} \right] \times \left[1 + \frac{R_2}{100} \right] \left[1 + \frac{R_3}{100} \right]$$



Solved Examples

Example 1: Calculate the simple interest if an amount of Rs. 1500 is deposited in ICICI Bank at 8% rate for 5 years.

Solution:

$$SI = \frac{P \times R \times T}{100}$$

$$SI = \frac{1500 \times 8 \times 5}{100} = \text{Rs. } 600$$

Example 2: A sum of 12000 Rs. is deposited into SBI Bank for 3 years. If the bank is providing 5% rate then calculate the amount after the maturity period?

Solution:

$$SI = \frac{PRT}{100}$$

$$SI = \frac{12000 \times 5 \times 3}{100} = \text{Rs. } 1800$$

Amount = Principal + SI

$$13800 = 12000 + 1800$$

Example 3: An amount become double in 8 years calculate the rate of interest?

Solution:

Let the amount be x Rs

Since it become double in 8 years so SI in 8 years = x Rs.

$$\text{Now } SI = \frac{P \times R \times T}{100}, \quad x = \frac{x \times R \times 8}{100}$$

$$\therefore R = \frac{100}{8} = 12\frac{1}{2}\%$$

Example 4: An Amount become 3 times in 12 years calculate the rate of interest?

Solution:

Let the amount be x Rs

Since it become triple in 12 years so

S.I. in 12 years = $2x$ Rs.

$$\text{Now } SI = \frac{PRT}{100}, \quad 2x = \frac{x \times R \times 12}{100}$$

$$R = \frac{200}{12} = 16\frac{2}{3}\%$$

Example 5: An amount become 5 times in 20 years. Calculate the rate of interest given?

Solution:

Principal = x Rs.

Total Amount = $5x$ Rs., So

SI = $4x$ Rs

$$\text{now } SI = \frac{PRT}{100}, \quad 4x = \frac{x \times R \times 20}{100}$$

$$R = \frac{400}{20} = 20\%$$

Example: 6

In how many years an amount become double if rate of interest given is 20%?

Solution:

Here principal = x

SI = x , R=20%

$$\text{Now } SI = \frac{PRT}{100}, \quad x = \frac{x \cdot 20 \cdot T}{100}$$

$$T = \frac{100}{20} = 5 \text{ years.}$$

Example: 7

A certain amount is deposited in the bank. If bank is giving 12% interest then calculate in how many years amount will become 3 times the principal?

Solution:

Here $p = x$, $A = 3x$

So, SI = $2x$

R = 12

$$SI = \frac{PRT}{100}, \quad 2x = \frac{x \times 12 \times T}{100}$$

$$T = \frac{200}{12} = 16\frac{2}{3} \text{ years.}$$

Example: 8

An amount of 25000 is deposited in to Citi bank for 2 years. Calculate the interest incurred if rate of interest is 10% compounded annually?

Here P= 25000 Rs.

$$R = 10\%$$

$$R = 2 \text{ years}$$

$$CI = P \left[1 + \frac{R}{100} \right]^T - P$$

$$= 25000 \left[1 + \frac{10}{100} \right]^2 - 25000$$

$$= 30250 - 25000 = \text{Rs. } 5250$$



Solved Example: 2

1. Rs. 1200 is lent out at 5% per annum simple interest for 3 years. Find the amount after 3 years.

- (a) Rs. 1380 (b) Rs. 1290
(c) Rs. 1470 (d) Rs. 1200

Ans. (a)

$$\text{Here } P = 1200 \text{ Rs.}$$

$$R = 5\%, T = 3 \text{ years}$$

$$SI = \frac{PRT}{100} = \frac{1200 \times 5 \times 3}{100} = 180 \text{ Rs.}$$

$$\text{Amount} = P + SI = 1200 + 180 = 1380$$

2. Interest obtained on a sum of Rs. 5000 for 3 years is Rs. 1500. Find the rate percent.

- (a) 8% (b) 9%
(c) 10% (d) 11%

Ans. (c)

$$\text{Here } P = 5000, SI = 1500, T = 3 \text{ years.}$$

$$R = \frac{SI \times 100}{P \times T} = \frac{1500 \times 100}{5000 \times 3} = 10\%$$

3. Rs. 2100 is lent at compound interest of 5% per annum for 2 years. Find the amount after two years.

- (a) Rs. 2300 (b) Rs. 2315.25
(c) Rs. 2310 (d) None of these

Ans. (b)

$$\text{Here } P = 2100, R = 5\%, T = 2 \text{ years.}$$

$$A = P \left[1 + \frac{R}{100} \right]^T = 2100 \left[1 + \frac{5}{100} \right]^2$$

$$= 2100 \times \frac{21}{20} \times \frac{21}{20} = 2315.25 \text{ Rs.}$$

4. Find the difference between the simple and the compound interest at 5% per annum for 2 years on a principal of Rs. 2000.

- (a) 5 (b) 105
(c) 4.5 (d) None of these

Ans. (a)

$$\text{Here } P = 2000 \text{ Rs., } R = 5\%, T = 2 \text{ years}$$

$$CI - SI = \left[P \left[1 + \frac{R}{100} \right]^T - P \right] - \frac{PRT}{100}$$

$$= \left\{ \left[2000 \times \frac{105}{100} \times \frac{105}{100} \right] - 2000 \right\}$$

$$- \frac{2000 \times 5 \times 2}{100}$$

$$= 205 - 200 = 5 \text{ Rs.}$$

5. After how many years will a sum of Rs. 12,500 become Rs. 17,500 at the rate of 10% per annum?

- (a) 2 years (b) 3 years
(c) 4 years (d) 5 years

Ans. (c)

$$\text{Here } A = 17500, P = 12500, R = 10\%$$

$$SI = A - P$$

$$= 17500 - 12500 = 5000$$

$$T = \frac{SI \times 100}{P \times R} = \frac{5000 \times 100}{12500 \times 10} = 4 \text{ years.}$$

6. What is the difference between the simple interest on a principal of Rs. 500 being calculated at 5% per annum for 3 years and 4% per annum for 4 years?

- (a) Rs. 5 (b) Rs. 10
(c) Rs. 20 (d) Rs. 40

Ans. (a)

$$P = 500 \text{ Rs.}, R_1 = 5\%, R_2 = 4\%, \\ T_1 = 3 \text{ years}, T_2 = 4 \text{ years}$$

$$\text{Difference} = \frac{PR_1T_1}{100} - \frac{PR_2T_2}{100} = 5 \text{ Rs.}$$

7. What is the simple interest on a sum of Rs. 700 if the rate of interest for the first 3 years is 8% per annum and for the last 2 years is 7% per annum?
- (a) 400 (b) 392
(c) 352 (d) 266

Ans. (d)

$$\frac{700 \times 3 \times 8}{100} + \frac{700 \times 2 \times 7}{100} = 266$$

8. Find the compound interest on Rs. 1000 at the rate of 20% per annum for 18 months when interest is compounded half-yearly.
- (a) Rs. 331 (b) Rs. 1331
(c) Rs. 320 (d) None of these

Ans. (a)

Here $P = 1000 \text{ Rs.}$, $R = 20\%$,

$T = 18 \text{ months}$ or $1\frac{1}{2} \text{ years}$.

Compound interest when interest is compounded annually

$$\text{CI} = 1000 \left[1 + \frac{R/2}{100} \right]^{2T} \\ = 1000 \left[1 + \frac{10}{100} \right]^3 = 1331 \text{ Rs.}$$

9. Find the principal if the interest compounded at the rate of 10% per annum for two years is Rs. 420.
- (a) Rs. 2000 (b) Rs. 2200
(c) Rs. 1000 (d) Rs. 1100

Ans. (a)

$P = ?$, $\text{CI} = 420 \text{ Rs.}$, $R = 10\%$, $T = 2 \text{ years}$.

$$\text{CI} = P \left[1 + \frac{R}{100} \right]^T - P$$

$$420 = P \left[\left(1 + \frac{10}{100} \right)^2 - 1 \right]$$

$$= P \left[\frac{21}{100} \right]$$

$$\therefore P = \frac{420 \times 100}{21} = 2000 \text{ Rs.}$$

10. At what percentage per annum, will Rs. 10,000 amount to 17,280 in three years? (Compound Interest being reckoned)
- (a) 20% (b) 14%
(c) 24% (d) 11%

Ans. (a)

$P = 10000 \text{ Rs.}$, $A = 17280 \text{ Rs.}$,

$T = 3 \text{ years}$, $R = ?$

$$A = P \left[1 + \frac{R}{100} \right]^T$$

$$17280 = 10000 \left[1 + \frac{R}{100} \right]^3$$

$$\left[\frac{17280}{10000} \right] = \left[1 + \frac{R}{100} \right]^3 = (1.2)^3$$

$$= \left[1 + \frac{R}{100} \right]^3, R = 20\%$$

11. What is the rate of simple interest for the first 4 years if the sum of Rs. 360 becomes Rs. 540 in 9 years and the rate of interest for the last 5 years is 6%?
- (a) 4% (b) 5%
(c) 3% (d) 6%

Ans. (b)

$P = 360 \text{ Rs.}$, $A = 540 \text{ Rs.}$, $\text{SI} = 180 \text{ Rs.}$

$$SI = \frac{PRT}{100}$$

$$180 = \frac{360 \times R \times 4}{100} + \frac{360 \times 6 \times 5}{100}$$

$$72 = \frac{360 \times R \times 4}{100}, R = 5\%$$

12. Vinod makes a deposit of Rs. 100,000 in the HDFC Bank for a period of 2 years. If the rate of interest be 12% per annum compounded half-yearly, what amount will he get after 2 years.

- (a) 122,247.89 (b) 125,436.79
(c) 126,247.69 (d) None of these

Ans. (c)

$P = 100000, R = 12\%, T = 2$ years

$$A = P \left[1 + \frac{R/2}{100} \right]^{4T}$$

$$A = 100000 \left[1 + \frac{6}{100} \right]^4 = 126247.69 \text{ Rs.}$$

13. What will be the simple interest on Rs. 700 at 9% per annum for the period from February 5, 1994 to April 18, 1994?

- (a) Rs. 12.60 (b) Rs. 11.30
(c) Rs. 15 (d) Rs. 13

Ans. (a)

Feb 5 to April 18, 1994

= 24 + 31 + 18 = 73 days = 0.2 years

$$SI = \frac{PRT}{100} = \frac{700 \times 9 \times 0.2}{100} = 12.6 \text{ Rs}$$

14. Ajay borrows Rs. 1500 from two money-lenders. He pays interest at the rate of 12% per annum for one loan and at the rate of 14% per annum for the other. The total interest he pays for the entire year is Rs. 186. How much does he borrow at the rate of 12%?

- (a) Rs. 1200 (b) Rs. 1300
(c) Rs. 1400 (d) Rs. 300

Ans. (a)

$P = 1500, R_1 = 12\%, R_2 = 14\%, T = 1$ year

SI = 186

Let x Rs. be amount invested at 12% Rate

$$= \frac{x \times 12 \times 1}{100} + \frac{(1500 - x) \times 14}{100} = 186$$

$$\frac{21000}{100} - \frac{2x}{100} = 186, x = 1200$$

15. A sum was invested at simple interest at a certain interest for 2 years. It would have fetched Rs. 60. more had it been invested at 2% higher rate. What was the sum?

- (a) Rs. 1500 (b) Rs. 1300
(c) Rs. 2500 (d) Rs. 1000

Ans. (a)

Since SI is directly proportional to Rate of interest

2% higher rate fetched Rs. 60 more

it means this sum will give SI of Rs. 60

if invested at 2% rate for 2 years

$$P = \frac{SI \times 100}{R \times T} = \frac{60 \times 100}{2 \times 2} = 1500$$

16. The difference between simple and compound interest on a sum of money at 5% per annum is Rs. 25. What is the sum?

- (a) Rs. 5000 (b) Rs. 10,000
(c) Rs. 4000 (d) Data insufficient

Ans. (d)

It cannot be determined.

17. Two equal sums were borrowed at 8% simple interest per annum for 2 years and 3 years respectively. The difference on the interest was Rs. 56. The sum borrowed were

- (a) Rs. 690 (b) Rs. 700
(c) Rs. 740 (d) Rs. 780

Ans. (b)

$$\frac{PRT_1}{100} - \frac{PRT_2}{100}$$

$$P \left[\frac{8 \times 3 - 8 \times 2}{100} \right] = 56, P = 700$$

18. If the difference between the simple interest and compound interest on some principal amount at 20% per annum for 3 years in Rs. 48, then the principle amount must be
- (a) Rs. 550 (b) Rs. 500
(c) Rs. 375 (d) Rs. 400

Ans. (c)

Here $P = ?$, $R = 20\%$, $T = 3$ year
Difference 48 Rs.

$$48 = P \left[1 + \frac{R}{100} \right]^T - P - \frac{PRT}{100}$$

$$48 = P \left[\left(1 + \frac{20}{100} \right)^3 - 1 - \frac{20 \times 3}{100} \right]$$

On solving $P = 375$.

19. Raju lent Rs. 400 to Ajay for 2 years, and Rs. 100 to Manoj for 4 years and received together from both Rs. 60 as interest. Find the rate of interest, simple interest being calculated.
- (a) 5% (b) 6%
(c) 8% (d) 9%

Ans. (a)

$$\frac{P_1 R_1 T_1}{100} + \frac{P_2 R_2 T_2}{100} = 60$$

$$\frac{400 \times 2 \times R}{100} + \frac{100 \times 4 \times R}{100} = 60$$

$$12R = 60, R = 5\%$$

20. In what time will Rs. 8000 amount to 40,000 at 4% per annum? (Simple interest being reckoned)
- (a) 100 years (b) 50 years
(c) 110 years (d) 160 years

Ans. (a)

$$P = 8000, A = 40000$$

$$R = 4\%, SI = 32000, T = ?$$

$$T = \frac{SI \times 100}{R \times P}$$

$$= \frac{32000 \times 100}{8000 \times 4} = 100 \text{ years}$$

21. A sum of money becomes 4 times at simple interest in 10 years. What is the rate of interest?

- (a) 10% (b) 20%
(c) 30% (d) 40%

Ans. (c)

Let sum be x
then $A = 4x$, $SI = 3x$

$$SI = \frac{PRT}{100}$$

$$3x = \frac{x \times 10 \times R}{100}$$

$$\text{So, } R = 30\%$$

22. A sum of money doubles itself in 5 years. In how many years will it become four fold (if interest is compounded)?

- (a) 15 (b) 10
(c) 20 (d) 12

Ans. (b)

Let sum = x

$$\text{Then, } 2x = x \left[1 + \frac{R}{100} \right]^5$$

$$\Rightarrow \left[1 + \frac{R}{100} \right] = 2^{1/5} \quad \dots(i)$$

$$4x = x \left[1 + \frac{R}{100} \right]^T$$

$$\Rightarrow 4 = [2^{1/5}]^T$$

$$\Rightarrow 2^2 = 2^{T/5}$$

$$\Rightarrow \frac{T}{5} = 2$$

$$\therefore T = 10 \text{ Yrs.}$$

23. A sum of money placed at compound interest doubles itself in 3 years. In how many years will it amount to 8 times itself?

- (a) 9 years (b) 8 years
(c) 27 years (d) 7 years

Ans. (a)

Let sum = x

$$\text{Then, } 2x = x \left[1 + \frac{R}{100} \right]^3$$

$$\Rightarrow \left[1 + \frac{R}{100} \right] = 2^{1/3} \quad \dots(i)$$

$$8x = x \left[1 + \frac{R}{100} \right]^T$$

$$\Rightarrow 8 = [2^{1/3}]^T$$

$$\Rightarrow 2^3 = 2^{T/3}$$

$$\Rightarrow \frac{T}{3} = 3$$

$$\therefore T = 9 \text{ Yrs.}$$

24. Divided Rs. 6000 into two parts so that simple interest on the first part for 2 years at 6% p.a. may be equal to the simple interest on the second part for 3 years at 8% p.a.

- (a) Rs. 4000, Rs. 2000
(b) Rs. 5000, Rs. 1000
(c) Rs. 3000, Rs. 3000
(d) None of these

Ans. (a)

Let one part be x Rs. then

$$\frac{x \times 2 \times 6}{100} = \frac{(6000 - x) \times 3 \times 8}{100}$$

$$12x = 144000 - 24x$$

$$36x = 144000$$

$$x = 4000$$

25. A sum of money becomes $7/4$ of itself in 6 years at a certain rate of simple interest. Find the rate of interest.

- (a) 12% (b) 12.5%
(c) 8% (d) 14%

Ans. (b)

Let sum be x

$$A = \frac{7}{4}x, \text{ So, } SI = \frac{3}{4}x$$

$$T = 6 \text{ years, } R = ?$$

$$R = \frac{SI \times 100}{P \times T} = \frac{\frac{3}{4}x \times 100}{x \times 6} = 12.5\%$$

26. Sanjay borrowed Rs. 900 at 4% p.a. and Rs. 1100 at 5% p.a. for the same duration. He had to pay Rs. 364 in all as interest. What is the time period in years?

- (a) 5 years (b) 3 years
(c) 2 years (d) 4 years

Ans. (d)

$$\frac{P_1 R_1 T_1}{100} + \frac{P_2 R_2 T_2}{100} = 364$$

$$\left[\frac{900 \times 4T}{100} + \frac{1100 \times 5T}{100} \right] = 364$$

$$36T + 55T = 364$$

$$T = 4 \text{ Years}$$

27. If a certain sum of money becomes double at simple interest in 12 years, what would be the rate of interest per annum?

- (a) $8\frac{1}{3}$ (b) 10
(c) 12 (d) 14

Ans. (a)

$$x = \frac{x \times 12 \times R}{100}$$

$$R = \frac{100}{12} = 8\frac{1}{3}$$

28. A sum of Rs. 600 amounts to Rs. 720 in 4 years at simple interest. What will it amount to if the rate of interest is increased by 2%?

- (a) Rs. 648 (b) Rs. 768
(c) Rs. 726 (d) Rs. 792

Ans. (b)

$$P = 600 \text{ Rs.}, \quad A = 720 \text{ Rs.}$$

$$T = 4 \text{ years}, \quad R = ?$$

$$R = \frac{\text{S.I.} \times 100}{P \times T} = \frac{120 \times 100}{600 \times 4} = 5\%$$

at 7% Rate

$$\text{SI} = \frac{600 \times 7 \times 4}{100} = 168$$

$$A = 600 + 168 = 768$$

□□□□

Simple Interest



Practice Exercise: I

- At the rate of 6% p.a. simple interest, a sum of Rs. 2500 will earn how much interest by the end of 5 years?
 - Rs. 150
 - Rs. 700
 - Rs. 750
 - Rs. 3250
- If A lends Rs. 3500 to B at 10% p.a. and B lends the same sum to C at 11.5% p.a., then the gain of B (in Rs.) in a period of 3 years is:
 - 107.50
 - 115.50
 - 157.50
 - 177.50
- Avinash borrowed Rs. 5000 From Sanjay at simple Interest. After 3years, Sanjay got Rs. 300 more than what he had given to Avinash. What was the rate of interest per annum?
 - 2%
 - 5%
 - 8%
 - 10%
- Rakesh took a loan for 6 years at the rate of 5% p.a. S.I. If the total interest paid was Rs. 1230, the principal was:
 - Rs. 4100
 - Rs. 4920
 - Rs. 5000
 - Rs. 5300
- Rs. 800 amounts to Rs. 920 in 3 years at simple interest. If the interest rate is increased by 3%, it would amount to how much?
 - Rs. 992
 - Rs. 1056
 - Rs. 1112
 - Rs. 1182
- The simple interest on a sum of money at 5% is Rs. 48 for 4 years. The simple interest on the same sum for 5 years at 4% will be.
 - Rs. 40
 - Rs. 48
 - Rs. 50
 - Rs. 60
- A sum of money at simple interest amounts to Rs. 2240 in 2 years and to Rs. 2600 in 5 years. What is the principal amount?
 - Rs. 1520
 - Rs. 1880
 - Rs. 2120
 - None
- The simple interest on a certain sum of money at the rate of 5% p.a. for 8 years in Rs. 840. At what rate of interest the same amount of interest can be received on the same sum after 5 years?
 - 6%
 - 8%
 - 9%
 - 10%
- A sum of money was lent at simple interest at 11% p.a. for $3\frac{1}{2}$ years and $4\frac{1}{2}$ years respectively. If the difference in interests for two period was Rs. 412.50, the sum is:
 - Rs. 3250
 - Rs. 3500
 - Rs. 3750
 - Rs. 4250
- Prabhat took a certain amount as a loan from a bank at the rate of 8% p.a. S.I. and gave the same amount to Ashish as a loan at the rate of 12% p.a. If at the end of 12 years, he made a profit of Rs. 320 in the deal, what was the original amount.
 - Rs. 2000
 - Rs. 3000
 - Rs. 4000
 - None of these

11. Rahul borrowed Rs. 830 from Mr. Lal at 12% p.a. S.I. for 3 years. He then added some more money to the borrowed sum and lent it to Shobha for the same period at 14% p.a. rate of interest. If Rahul gains Rs. 93.90 in the whole transaction, how much money did he add from his side?
 (a) Rs. 35 (b) Rs. 55
 (c) Rs. 80 (d) Rs. 105
12. The simple interest on Rs. 1820 from March 9, 1994 to May 21, 1994 at $7\frac{1}{2}\%$ rate will be
 (a) Rs. 29 (b) Rs. 28.80
 (c) Rs. 27.30 (d) Rs. 22.50
13. Mr. Roopchand finds that an increase in the rate of interest from $4\frac{1}{8}\%$ to $5\frac{1}{8}\%$ per annum increases his yearly income by Rs. 25. His investment is:
 (a) Rs. 10,000 (b) Rs. 12,000
 (c) Rs. 15,000 (d) Rs. 20,000
14. The rate at which a sum becomes four times of itself in 15 years at S.I. will be:
 (a) 15% (b) $17\frac{1}{2}\%$
 (c) 20% (d) 25%
15. The simple interest accrued on a sum of money at the end of four years is $\frac{1}{5}$ th of its principal. What is the rate of interest per annum?
 (a) 4% (b) 5%
 (c) 6% (d) Data inadequate
16. A sum of money triples itself in 15 years 6 months. In how many years would it double itself?
 (a) 6 years 3 months
 (b) 7 years 9 months
 (c) 8 years 3 months
 (d) 9 years 6 months
17. The simple interest on a sum of money is $\frac{1}{9}$ of the sum. The number of years is numerically equal to the rate percent per annum. The rate percent per annum is:
 (a) $3\frac{1}{3}$ (b) 5
 (c) $6\frac{2}{3}$ (d) 10
18. A sum of Rs. 10 is lent to be returned in 11 monthly installments of Re. 1 each, interest being simple. The rate of interest is:
 (a) $9\frac{1}{11}\%$ (b) 10%
 (c) 11% (d) $21\frac{9}{11}\%$
19. The rate of simple interest on a sum of money is 6% p.a. for the first 3 years, 8% p.a. for the next 5 years and 10% p.a. for the period beyond 8 years. If the simple interest accrued by the sum for a total period of 10 years is Rs. 1560, what is the sum?
 (a) Rs. 1500 (b) Rs. 2000
 (c) Rs. 3000 (d) Data inadequate
20. A monthly installment of Rs. 180 is required to be paid for repayment of an interest free loan in 40 months. If it is decided to pay it in 30 months, how much will be the monthly installment in rupees?
 (a) 60 (b) 198
 (c) 240 (d) 330
21. A sum of Rs. 1550 is lent out into two parts, one at 8% and another one at 6%. If the total annual income is Rs. 106, the money lent at 8% is:
 (a) Rs. 650 (b) Rs. 720
 (c) Rs. 840 (d) Rs. 900

22. A sum of Rs. 1550 was lent partly at 5% and partly at 8% p.a. simple interest. The total interest received after 3 years was Rs. 300. The ratio of the money lent at 5% to that lent at 8%.

- (a) 8 : 5 (b) 5 : 8
(c) 31 : 6 (d) 16 : 15

23. What should be the least number of years in which the simple interest on Rs. 2600 at

$6\frac{2}{3}\%$ will be an exact number of rupees?

- (a) 2 (b) 3
(c) 4 (d) 5

24. A man invests an amount of Rs. 15860 in the names of his three sons A, B and C in such a way that they get the same amount after 2, 3 and 4 years respectively. If the rate of simple interest is 5%, then the ratio of amounts invested among, A, B and C will be:

- (a) 10 : 15 : 20 (b) 22 : 23 : 24
(c) 6 : 4 : 3 (d) 2 : 3 : 4

25. Rs. 2189 are divided into three parts such that their amounts after 1, 2 and 3 years respectively may be equal, the rate of simple interest being 4% p.a. in all cases. The smallest part is:

- (a) Rs. 702 (b) Rs. 597
(c) Rs. 756 (d) Rs. 1093

Solutions

1. Ans. (c)

$$S.I. = Rs. \left(2500 \times 6 \times \frac{5}{100} \right) = Rs. 750.$$

2. Ans. (c)

$$\begin{aligned} \text{Gain} &= Rs. \left(\frac{3500 \times 11.5 \times 3}{100} - \frac{3500 \times 10 \times 3}{100} \right) \\ &= Rs. (1207.5 - 1050) = Rs. 157.50. \end{aligned}$$

3. Ans. (a)

$$\text{Rate} = \left(\frac{100 \times 300}{5000 \times 3} \right) \% = 2\%.$$

4. Ans. (a)

$$\text{Principal} = Rs. \left(\frac{1230 \times 100}{6 \times 5} \right) = Rs. 4100.$$

5. Ans. (a)

Principal = Rs. 800, S.I. = Rs. 120,
Time = 3 years.

$$\therefore \text{Rate} = \left(\frac{100 \times 120}{800 \times 3} \right) \% = 5\%.$$

New rate = 8%, Principal = Rs. 800,
Time 3 years.

$$S.I. = Rs. \left(\frac{800 \times 8 \times 3}{100} \right) = Rs. 192.$$

\therefore New amount = Rs. (800 + 192) = Rs. 992

6. Ans. (b)

$$\text{Principal} = Rs. \left(\frac{100 \times 48}{5 \times 4} \right) = Rs. 240.$$

$$S.I. = Rs. \left(\frac{240 \times 5 \times 4}{100} \right) = Rs. 48$$

7. Ans. (d)

S.I. for = Rs. (2600 - 2240) = Rs. 360.

$$S.I. \text{ For 2 years} = Rs. \left(\frac{360}{3} \times 2 \right) = Rs. 240$$

\therefore Principal = Rs. (2240 - 240) = Rs. 2000

8. Ans. (b)

$$\text{Sum} = \left(\frac{100 \times 840}{5 \times 8} \right) = Rs. 2100.$$

$$\text{Rate required} = \left(\frac{100 \times 840}{2100 \times 5} \right) \% = 8\%.$$

9. Ans. (c)

Let the sum be Rs. x . Then,

$$\left(x \times 11 \times \frac{9}{2} \times \frac{1}{100} - x \times 11 \times \frac{7}{2} \times \frac{1}{100} \right) = 412.50$$

$$\text{or } \frac{22x}{200} = 412.50$$

$$\Rightarrow 11x = 41250$$

$$\Rightarrow x = 3750$$

10. Ans. (d)

Let the original amounts be Rs. x . then,

$$\frac{x \times 12 \times 12}{100} - \frac{x \times 8 \times 12}{100} = 320$$

$$\Rightarrow x = \frac{2000}{3} = \text{Rs. } 666.67$$

11. Ans. (d)

$$\frac{(830+x) \times 14 \times 3}{100} - \frac{830 \times 12 \times 3}{100} = 93.90$$

$$\text{or } 830 \times 42 + 42x - 830 \times 36 = 9390$$
$$42x = 9390 - 4980$$

$$\Rightarrow x = \frac{4410}{42} = 105.$$

\therefore Money added = Rs. 105.

12. Ans. (c)

March, April, May

$$22 + 30 + 21 = 73 \text{ days}$$

$$= \frac{73}{365} \text{ years} = \frac{1}{5} \text{ years.}$$

\therefore Interest

$$= \text{Rs.} \left(1820 \times \frac{1}{5} \times \frac{15}{2 \times 100} \right) = \text{Rs. } 27.30$$

13. Ans. (a)

Let the investment be Rs. x . Then,

$$x \times \frac{41}{8} \times \frac{1}{100} - x \times \frac{39}{8} \times \frac{1}{100} = 25$$

$$\Rightarrow 2x = 20000 \Rightarrow x = 10000.$$

14. Ans. (c)

Let sum = x , Then, S. I. = $3x$

$$\therefore \text{Rate} = \left(\frac{100 \times 3x}{x \times 15} \right) \% = 20\%$$

15. Ans. (b)

Let sum = x , Then, S.I. = $\frac{x}{5}$, Time = 4 years.

$$\therefore \text{Rate} = \left(100 \times \frac{x}{5} \times \frac{1}{x \times 4} \right) \% = 5\%.$$

16. Ans. (b)

Let sum = x ,

Then, S.I. = $2x$ & Time = $\frac{31}{2}$ years.

$$\text{Rate} = \left(\frac{100 \times 2x}{x} \times \frac{2}{31} \right) \% = \left(\frac{400}{31} \right) \%$$

Now, sum = x , S.I. = x & Rate $\left(\frac{400}{31} \right) \%$

$$\therefore \text{Time} = \left(\frac{100 \times x}{x} \times \frac{31}{400} \right) \text{ years}$$

$$= 7 \text{ years } 9 \text{ months}$$

17. Ans. (a)

Let sum = x , Then, S.I. = $\frac{x}{9}$.

Let time = n years and rate = $n\%$

$$\text{Then, } \therefore n = 100 \times \frac{x}{9} \times \frac{1}{x} \times \frac{1}{n}$$

$$\text{or } n^2 = \frac{100}{9} \text{ or } n = \frac{10}{3} = 3\frac{1}{3}\%.$$

18. Ans. (d)

Rs. 10 + S.I. on Rs. 10 for 11 months
 = Rs. 11 + S. I. on Re 1 for (1 + 2 + 3 + 4 +
 + 10) months

Rs. 10 + S.I. on Re 1. for 110 months

= Rs. 11 + S.I. on Re 1 for 55 months

S.I. on Re 1 for 55 months = Re 1.

$$\therefore \text{Rate} = \left(\frac{100 \times 12}{1 \times 55} \right) \% = 21\frac{9}{11} \%$$

19. Ans. (b)

Let the sum be Rs. x . Then

$$\frac{x \times 6 \times 3}{100} + \frac{x \times 8 \times 5}{100} + \frac{x \times 10 \times 2}{100} = 1560$$

$$\text{or } 78x = 156000$$

$$\text{or } x = 2000$$

20. Ans. (c)

$$180 \times 40 = x \times 30 \text{ or } x = 240$$

21. Ans. (a)

Let the money lent at 8% be Rs. x . then,

$$\frac{x \times 8 \times 1}{100} + \frac{(1550 - x) \times 6 \times 1}{100} = 106$$

$$\text{or } 2x + 9300 = 10600 \text{ or } x = 650.$$

22. Ans. (d)

Let the sum at 5% be Rs. x . Then,

$$\frac{x \times 5 \times 3}{100} + \frac{(1550 - x) \times 8 \times 3}{100} = 300$$

$$\text{or } x = 800$$

$$\frac{\text{Money at 5\%}}{\text{Money at 8\%}} = \frac{800}{(1550 - 800)}$$

$$= \frac{800}{750} = \frac{16}{15}$$

23. Ans. (b)

$$\text{S.I.} = \text{Rs.} \left(2600 \times \frac{20}{3} \times \frac{1}{100} \times T \right)$$

$$= \text{Rs.} \left(\frac{520}{3} \times T \right), \text{ which is an exact number of rupees So } T=3$$

24. Ans. (c)

Let the amounts invested be x, y, z respectively.

$$\text{Then, } \frac{x \times 2 \times 5}{100} = \frac{y \times 3 \times 5}{100} = \frac{z \times 4 \times 5}{100} = k.$$

$$\therefore x = 10k, y = \frac{20}{3}k \text{ \& } z = 5k.$$

$$\text{So, } x : y : z = 10k : \frac{20}{3}k : 5k$$

$$= 30 : 20 : 15 = 6 : 4 : 3.$$

25. Ans. (b)

Let these parts i.e. x, y and $[2189 - (x + y)]$.

Then,

$$\therefore \frac{x \times 1 \times 4}{100} = \frac{y \times 2 \times 4}{100}$$

$$= \frac{[2189 - (x + y)] \times 3 \times 4}{100}$$

$$\therefore \frac{x}{y} = 2 \text{ or } x = 2y.$$

$$\therefore \frac{2y \times 1 \times 4}{100} = \frac{(2189 - 3y) \times 3 \times 4}{100}$$

$$\text{or } 44y = 2189 \times 12.$$

$$\therefore y = \left(\frac{2189 \times 12}{44} \right) = 597.$$

$$\therefore \text{Smallest part} = \text{Rs. } 597.$$

□□□□

Compound Interest



Practice Exercise: I

- The amount of Rs. 7500 at compound interest at 4% per annum for 2 years, is:
(a) Rs. 7800 (b) Rs. 8100
(c) Rs. 8112 (d) Rs. 8082
- The difference between the compound interest and the simple interest on a sum of money for 2 years at 12.5% per annum in Rs. 150. The sum is:
(a) Rs. 9000 (b) Rs. 9200
(c) Rs. 9500 (d) Rs. 9600
- The difference in compound interest, and simple interest on a certain amount at 10% per annum at the end of the third year is Rs. 620. What is the principal amount?
(a) Rs. 40000 (b) Rs. 12000
(c) Rs. 10000 (d) Rs. 20000
- If the compound interest on a certain sum at $16\frac{2}{3}\%$ for 3 years is Rs. 1270, the simple interest on the same sum at the same rate and for the same period is:
(a) Rs. 1200 (b) Rs. 1165
(c) Rs. 1080 (d) Rs. 1220
- The compound interest on a certain sum at 5% per annum for 2 years is Rs. 328. The simple interest for that sum at the same rate and for the same period will be:
(a) Rs. 320 (b) Rs. 322
(c) Rs. 325 (d) Rs. 326
- What is principal amount which earns Rs. 132 as compound interest for the second year at 10% per annum?
(a) Rs. 1000 (b) Rs. 1200
(c) Rs. 1320 (d) Rs. 1188
- A sum of money at compound interest amounts to Rs. 578.40 in 2 years and to Rs. 614.55 in 3 years. The rate of interest per annum is:
(a) 4% (b) 5%
(c) $6\frac{1}{4}\%$ (d) $8\frac{1}{3}\%$
- A sum of money amounts to Rs. 4624 in 2 years and to Rs. 4913 in 3 years at compound interest. The sum is:
(a) Rs. 4096 (b) Rs. 4260
(c) Rs. 4335 (d) Rs. 4360
- A sum of money at compound interest amounts to thrice itself in 3 years. In how many years will it be 9 times itself?
(a) 12 (b) 9
(c) 6 (d) 8
- In how many years will a sum of Rs. 800 at 10% per annum compounded semiannually become Rs. 926.10?
(a) $2\frac{1}{2}$ (b) $1\frac{1}{2}$
(c) $2\frac{1}{3}$ (d) $1\frac{1}{3}$
- To find out the total compound interest accrued on a sum of money after 5 years, which of the following informations given in the statements P and Q will be sufficient?
P : The sum was Rs. 20000.
Q : The total amount of simple interest on the sum after 5 years was Rs. 4000.
(a) Only P is sufficient
(b) Only Q is sufficient
(c) Either P or Q is sufficient
(d) Both P & Q are needed
(e) Both P and Q are not sufficient.
- The least number of complete years in which a sum of money put out at 20% compound interest will be more than doubled is:
(a) 3 (b) 4
(c) 5 (d) 6

13. A tree increase annually by $\frac{1}{8}$ th of its height.

By how much will it increase after 2 years, if it stands today 64 cm high?

- (a) 72 cm (b) 74 cm
(c) 75 cm (d) 81 cm
14. The compound interest on a sum for 2 years is Rs. 832 and the simple interest on the same sum for the same period is Rs. 800. The difference between the compound interest and the simple interest for 3 years will be :
- (a) Rs. 48 (b) 66.56
(c) Rs. 98.56 (d) None of these
15. A sum of money becomes Rs. 13380 after 3 years and Rs. 20070 after 6 years on compound interest. The sum is:
- (a) Rs. 8800 (b) Rs. 8890
(c) Rs. 8920 (d) Rs. 9040
16. A sum of Rs. 1100 was taken as a loan. This is to be repaid in two equal installments. If the rate of interest be 20% compounded annually, then the value of each installments is:
- (a) Rs. 842 (b) Rs. 792
(c) Rs. 720 (d) Rs. 700
17. The compound interest on Rs. 8000 at 15% per annum for 2 years 4 months, compounded annually is:
- (a) Rs. 2980 (b) Rs. 3091
(c) Rs. 3109 (d) Rs. 3100
18. What annual payment will discharge a debt of Rs. 7620 due in 3 years at $16\frac{2}{3}\%$ per annum compound interest?
- (a) Rs. 2540 (b) Rs. 3430
(c) Rs. 3260 (d) Rs. 3380

19. A sum of money invested at compound interest amounts to Rs. 800 in 3 years and Rs. 840 in 4 years. What is the rate of interest per annum?

- (a) 2% (b) 4%
(c) 5% (d) 10%

20. A sum of money becomes 8 times of itself in 3 years at compound interest. The rate of interest is:

- (a) 100% (b) 8%
(c) 1% (d) Data inadequate

Solutions

1. Ans. (c)

$$\begin{aligned} \text{Amount} &= \text{Rs.} \left[7500 \times \left(1 + \frac{4}{100} \right)^2 \right] \\ &= \text{Rs.} \left(7500 \times \frac{26}{25} \times \frac{26}{25} \right) = \text{Rs.} 8112. \end{aligned}$$

2. Ans. (d)

Let the sum be Rs. x . Then,

$$\text{C.I.} = x \left(1 + \frac{25}{2 \times 100} \right)^2 - x$$

$$= \left(\frac{9}{8} \times \frac{9}{8} \right) x - x = \frac{17x}{64}$$

$$\text{S.I.} = \left(x \times \frac{25}{2} \times 2 \times \frac{1}{100} \right) = \frac{x}{4}$$

$$(\text{C.I.}) - (\text{S.I.}) = \left(\frac{17x}{64} - \frac{x}{4} \right) = \frac{x}{64}$$

$$\therefore \frac{x}{64} = 150 \text{ or } x = 9600.$$

3. Ans. (d)

Let the sum be Rs. x . Then,

$$\text{C.I.} = x \left(1 + \frac{10}{100} \right)^3 - x$$

$$= \left(\frac{1331}{1000} - x \right) = \frac{331x}{1000}$$

$$\text{S.I.} = \frac{x \times 10 \times 3}{100} = \frac{3x}{10}$$

$$\therefore (\text{C.I.}) - (\text{S.I.}) = \left(\frac{331x}{1000} - \frac{3x}{100} \right) = \frac{31x}{1000}$$

$$\therefore \frac{31x}{1000} = 620$$

$$\text{or } x = 20000.$$

Hence, the principal amount is Rs. 20000.

4. Ans. (c)

Let the sum be Rs. x . Then,

$$\text{C.I.} = \left[x \times \left(1 + \frac{50}{3 \times 100} \right)^3 \right] - x$$

$$= \left(\frac{343x}{216} - x \right) = \frac{127x}{216}$$

$$\therefore \frac{127x}{216} = 1270$$

$$\text{or } x = \frac{1270 \times 216}{127} = 2160.$$

Thus, the sum is Rs. 2160.

$$\therefore \text{S.I.} = \text{Rs.} \left(2160 \times \frac{50}{3} \times 3 \times \frac{1}{100} \right)$$

$$= \text{Rs. } 1080.$$

5. Ans. (a)

Let the sum be Rs. x . Then,

$$\text{C.I.} = x \left(1 + \frac{5}{100} \right)^2 - x$$

$$= \left(\frac{441x}{400} - x \right) = \frac{41x}{400}$$

$$\therefore \frac{41x}{400} = 328 \text{ or } x = \frac{328 \times 400}{41} = 3200.$$

$$\therefore \text{S.I.} = \text{Rs.} \left(\frac{3200 \times 5 \times 2}{100} \right) = \text{Rs. } 320.$$

6. Ans. (b)

Let the principal at the end of first year be Rs. x .

$$\text{Then, } \frac{x \times 10 \times 1}{100} = 132 \text{ or } x = 1320.$$

Now, let the original principal be Rs. P .

Then, amount after 1 year

$$= P + \frac{P \times 10 \times 1}{100} = \frac{11P}{10}$$

$$\therefore \frac{11P}{10} = 1320$$

$$\text{or } P = \frac{1320 \times 10}{11} = \text{Rs. } 1200.$$

7. Ans. (d)

Interest on Rs. 578.40 for 1 year

$$= \text{Rs. } (614.55 - 578.40) = \text{Rs. } 36.15.$$

$$\therefore \text{Rate} = \left(\frac{100 \times 36.15}{578.40} \right) \% = 6\frac{1}{4}\%.$$

8. Ans. (a)

Interest on Rs. 4624 for 1 year

$$= \text{Rs. } (6083.50 - 5290) = \text{Rs. } 793.50$$

$$\therefore \text{Rate} = \left(\frac{100 \times 793.50}{4624 \times 1} \right) \% = 6\frac{1}{4}\%$$

$$\text{Now, } x \left(1 + \frac{25}{4 \times 100} \right)^2 = 4624$$

$$\text{or } x \times \frac{17}{16} \times \frac{17}{16} = 4624$$

$$\therefore x = \left(4624 \times \frac{16}{17} \times \frac{16}{17}\right) = \text{Rs. } 4096.$$

9. Ans. (c)

$$P\left(1 + \frac{R}{100}\right)^3 = 3P \Rightarrow \left(1 + \frac{R}{100}\right)^3 = 3 \quad \dots(i)$$

$$\text{Let } P\left(1 + \frac{R}{100}\right)^n = 9P \Rightarrow \left(1 + \frac{R}{100}\right)^n = 9.$$

$$\therefore \left(1 + \frac{R}{100}\right)^n = 3^2$$

$$= \left[\left(1 + \frac{R}{100}\right)^3\right]^2 = \left(1 + \frac{R}{100}\right)^6 \quad (\text{using (i)})$$

Hence, $n=6$ years.

10. Ans. (b)

Rate = 5% per half year.

Let time = $2n$ half years = n years.

$$\text{Then, } 800\left(1 + \frac{5}{100}\right)^{2n} = 926.10$$

$$\Rightarrow \left(\frac{21}{20}\right)^{2n} = \frac{926.10}{800} = \frac{9261}{8000} = \left(\frac{21}{20}\right)^3$$

$$\therefore 2n = 3 \text{ or } n = \frac{3}{2} \text{ years.}$$

11. Ans. (d)

Clearly, both P and Q together are needed.

Using P and Q rate can be calculated as

$$\text{Rate} = \left(\frac{100 \times 4000}{5 \times 20000}\right) = 4\%$$

Now, C. I. can be calculated.

12. Ans. (b)

$$P = \left(1 + \frac{20}{100}\right)^n > 2P \text{ or } \left(\frac{6}{5}\right)^n > 2$$

$$\text{Now } \left(\frac{6}{5} \times \frac{6}{5} \times \frac{6}{5} \times \frac{6}{5}\right) > 2$$

So, $n = 4$ years.

13. Ans. (d)

$$\text{Increase \%} = \left(\frac{1}{8} \times 100\right)\% = 12\frac{1}{2}\%.$$

Height after 2 years

$$= \left[64 \times \left(1 + \frac{25}{2 \times 100}\right)^2\right] \text{ cm}$$

$$= \left(64 \times \frac{9}{8} \times \frac{9}{8}\right) \text{ cm} = 81 \text{ cm.}$$

14. Ans. (c)

Diff. in C.I. & S.I. for 2 years = Rs. 32.

S.I. for 1 year = Rs. 400.

\therefore S.I. on Rs. 400 for 1 year = Rs. 32.

$$\therefore \text{Rate} = \left(\frac{100 \times 32}{400 \times 1}\right)\% = 8\%.$$

Hence, diff. in C.I. and S.I. for 3rd year

= S.I. on Rs. 832

$$= \text{Rs.} \left(832 \times \frac{8}{100} \times 1\right) = \text{Rs. } 66.56.$$

Total difference = Rs. (32 + 66.56)

= Rs. 98.56

15. Ans. (c)

Let the sum be Rs. x . then,

$$x\left(1 + \frac{R}{100}\right)^3 = 13380$$

$$\& \quad x\left(1 + \frac{R}{100}\right)^6 = 20070$$

On dividing, we get $\left(1 + \frac{R}{100}\right)^3$

$$= \frac{20070}{13380} = \frac{3}{2}$$

$$\therefore x \times \frac{3}{2} = 13380$$

$$\Rightarrow x = \left(13380 \times \frac{2}{3}\right) = 8920.$$

Hence, the sum is Rs. 8920.

16. Ans. (c)

Let the value of each installment be Rs. x .

Then,

(P.W. of Rs. x due 1 year hence) + (P.W. of Rs. x due 2 years hence) = Rs. 1100.

$$= \frac{x}{\left(1 + \frac{20}{100}\right)} + \frac{x}{\left(1 + \frac{20}{100}\right)^2} = 1100$$

$$\text{or } \frac{5x}{6} + \frac{25x}{36} = 1100 \quad 55x = 36 \times 1100$$

$$\therefore x = \left(\frac{36 \times 1100}{55}\right) = \text{Rs. } 720.$$

17. Ans. (c)

$$\text{Time} = 2 \text{ years } 4 \text{ months} = 2\frac{4}{12} \text{ years}$$

$$= 2\frac{1}{3} \text{ years.}$$

$$\therefore \text{C.I.} =$$

$$\text{Rs. } \left[8000 \times \left(1 + \frac{15}{100}\right)^2 \times \left(1 + \frac{\frac{1}{3} \times 15}{100}\right) - 8000 \right]$$

$$= \text{Rs. } \left(8000 \times \frac{23}{20} \times \frac{23}{20} \times \frac{21}{20} - 8000 \right)$$

$$= \text{Rs. } 3109.$$

18. Ans. (b)

Let each installment be Rs. x . Then,

$$\frac{x}{\left(1 + \frac{50}{3 \times 100}\right)} + \frac{x}{\left(1 + \frac{50}{3 \times 100}\right)^2}$$

$$+ \frac{x}{\left(1 + \frac{50}{3 \times 100}\right)^3} = 7620.$$

$$\text{or } \frac{6x}{7} + \frac{36x}{49} + \frac{216x}{343} = 7620.$$

$$294x + 252x + 216x = 7620 \times 343$$

$$\text{or } x = \frac{7620 \times 343}{762} = 3430.$$

\therefore Amount of each installment = Rs. 3430.

19. Ans. (c)

Interest on Rs. 800 for 1 year

= Rs. (840 - 800) = Rs. 40.

$$\therefore \text{Rate} = \left(\frac{100 \times 40}{800 \times 1}\right)\% = 5\%.$$

20. Ans. (a)

$$P \left(1 + \frac{R}{100}\right)^3 = 8P$$

$$\text{or } \left(1 + \frac{R}{100}\right)^3 = 8 = 2^3$$

$$\therefore 1 + \frac{R}{100} = 2$$

$$\text{or } \frac{R}{100} = 1$$

$$\text{or } R = 100.$$

□□□□





Time & Work

In real life situations we come across practical problems of accomplishing the given project in prescribed time limit. Since efficiency of different person is different, the management has to take proper note of it before distributing the task to subordinates or executives. We discussed all such problems under the heading 'Time and work'.

Theory

Let a person A can finish a task in x days and person B can finish it in y days. Then

A can finish $\frac{1}{x}$ Part of work in a day and B can

finish $\frac{1}{y}$ part of work in a day if both will be working together to finish the task as soon as possible then in a day they can finish

$$\frac{1}{x} + \frac{1}{y} = \frac{x+y}{xy}$$

part of the work so to finish the work it require

$$\frac{xy}{x+y} \text{ days.}$$

Example 1: A can finish the task in 8 day and B can finish the same task in 12 days. How many days are required to finish the task if both are working together?

Solution:

A can finish the task in 8 days

so in a day A can finish $\frac{1}{8}$ part of work

B can finish the task in 12 days

so in a day B can finish $\frac{1}{12}$ part of work if

both are working simultaneously then in a day they can finish.

$$\frac{1}{8} + \frac{1}{12} = \frac{20}{8 \times 12} = \frac{5}{24} \text{ Part of work so the}$$

whole task will be finished in $\frac{24}{5}$ days ie 4.8

days.

Example 2: x can complete a work in 8 days, y can do the same work in 24 days. If both are working together then the task will be finished in how many days?

Solution:

Here $x = 8$, $y = 24$

$$\text{Total number of days required} = \frac{xy}{x+y}$$

$$= \frac{8 \times 24}{8 + 24} = 6 \text{ days.}$$

When A and B work in alternate days. Case I
starting from A.

Let A can finish the task in 8 days and B can finish the same task in 10 days. How many days are required to finish the task if both are working in alternate days.?

Solution:

A can finish the task in 8 days

So A's work in a day = $\frac{1}{8}$ part

B can finish the task in 10 days

So B's work in a day $\frac{1}{10}$ part

Both are working alternately starting from A.

then in two days they can finish $\frac{1}{8} + \frac{1}{10}$ part

i.e. In first day A will finish $\frac{1}{8}$ part

In second day B will finish $\frac{1}{10}$ part

$$\Rightarrow \frac{8+10}{80} = \frac{18}{80}$$

If they continue in such a manner together in

8 days they can finish $\frac{72}{80}$ part of work. Still

$\frac{8}{80}$ or $\frac{1}{10}$ part is remaining which is to be

finished by A in 9th days so, to finish $\frac{1}{10}$

part A needs

$$\frac{1}{10} = \frac{8}{10} = \frac{4}{5} \text{ days. } \frac{1}{8}$$

So, together they can finish the task in $8\frac{4}{5}$

days.

Case II:

In the above question calculate number of days

required to finish the task by A and B if both are working alternately starting from B

Solution:

The explanation remains the same from 1st

day to 8th day. In 9th day $\frac{1}{10}$ still remains

which has to be finished by B.

B can finish $\frac{1}{10}$ part of work in $\frac{\frac{1}{10}}{\frac{1}{10}} = 1$ day

So, together they can complete the task in 9 days.

Concept of Negative Work

Supposing A and B are working to build a wall while C is working to break the wall. In such case the wall is being built by A and B while it is broken by C. Here if we consider the work as building of the wall, we can say that C is doing negative work.

Example: A can build a wall in 8 days and B can build it in 12 days while C can completely destroy it in 24 days. If they start working at the same time, in how many days will the work be completed.

Solution:

The net combined work per day here is

A's work + B's work - C's work

$$\Rightarrow \frac{1}{8} + \frac{1}{12} - \frac{1}{24} = \frac{3+2-1}{24} = \frac{4}{24} = \frac{1}{6}$$

Hence the work will be completed in 6 days.

The concept of negative work commonly appears as a problem based on pipes and cisterns, where there inlet pipes and outter/leaks which are working against each other.

Ex.1 A tortoise can climb upto 5m in first hour. Next hour it climbs down to 4m. It is trying to reach a platform of 15m. Find number of hours require to the tortoise to climb up the platform.

Sol.: It is very clear that tortoise can climb up to 5m per hour.

Effective climbing in the last hour will be 5m. Remaining time in which tortoise will climb up to platform can be calculated by simple logic.

- ∴ First hour climb up 5m
 - next hour climb down by 4m
 - ∴ Effective work within 2 hour = 1m.
 - ∴ 1m climbing requires 2 hours.
 - ∴ 10 m Climbing will require 20 hours.
- Total time required by tortoise to climb up to 15m is 20 + 1 = 21 hours.

Ex.2 A snail is trying to reach at the top level of wooden stick which is 95 cm long. Snail can climb up to 5cm in first hour but climb down to 3 cm in next hour. Find the time required by snail to reach the top of wooden stick.

Sol.: Snail climb 5cm in last hour. Remaining time in which snail will climb stick can be calculated by simple method:

- 5cm climbing up in first hour & 3cm climbing down in next hour
 - ∴ Effective work done by snail will be 2cm in 2 hour.
 - ∴ 90cm can be climbed in 90 hours.
- Total time required by snail will be 90 + 1 = 91 hours.

Pipes and Cisterns

Pipes are connected to a tank or cistern and are used to fill or empty the tank

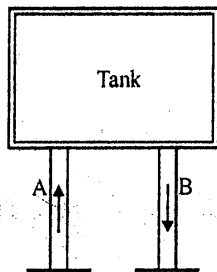

Inlet: is a pipe which is used to fill the tank. In the given figure pipe A is inlet

Outlet: is a pipe connected to a tank and is used for emptying the tank. In the figure pipe is outlet.

1. If a inlet can completely fill the empty tank in x hours, the part of the tank filled in 1 hour

$$= \frac{1}{x}$$

2. If an outlet can empty the tank in y hours

then the part of tank emptied in 1 hour = $\frac{1}{y}$

3. If both inlet and outlet are open, net part of

the tank filled in 1 hours = $\frac{1}{x} - \frac{1}{y}$

A tank can have large number of inlet and outlet.

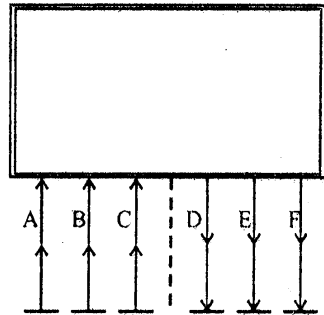

Here in the figure A, B and C are inlets while D, E and F are outlets.

Let A, B and C can fill the tank in X_1 , X_2 , and X_3 hours respectively and

D, E and F can empty the full tank in Y_1 , Y_2 , and Y_3 hours respectively then the net part of the tank filled in 1 hour

$$= \left[\frac{1}{X_1} + \frac{1}{X_2} + \frac{1}{X_3} \right] - \left[\frac{1}{Y_1} + \frac{1}{Y_2} + \frac{1}{Y_3} \right]$$

Examples: A pipe can fill the tank in 5 hours and pipe B can empty the full tank in 10 hours. Calculate the time required to fill the tank if both are running simultaneously.

Solution:

Here $x = 5$, $y = 10$

so, net part of the tank filled in 1 hours

$$= \frac{1}{5} - \frac{1}{10} = \frac{1}{10}$$

so the tank will be filled in 10 hours.

Example: Two inlet pipe can fill the tank in 10 and 20 hours respectively while two outlet pipes can empty the full tank in 30 and 25 hours respectively. Find the time required to fill the tank if all pipes are running simultaneously?

Solution:

Here $X_1 = 10$, $X_2 = 20$
 $Y_1 = 30$, $Y_2 = 25$

so net part of the tank filled in 1 hour

$$\left[\frac{1}{10} + \frac{1}{20} \right] - \left[\frac{1}{30} + \frac{1}{25} \right]$$

$$= \frac{3}{20} - \frac{11}{150} = \frac{23}{300}$$

So the tank will be filled in $\frac{300}{23} = 13.04$ hours

Concept of Man-Day

If 100 workers can finish the task in 50 days, then 1 worker can finish the task in $100 \times 50 = 5000$ day.

This is represented in form of man-day

So, man day is nothing but the time required to finish the task by 1 person.

Three Cases:

Case-I.

Let 100 workers can finish the task in 50 days, then how many days are required to finish the task by 25 workers?

Solution:

Here man Day = $100 \times 50 = 5000$

how according to question only 25 workers are available so

$$25 \times \text{day} = 5000$$

$$\text{Day} = \frac{5000}{25} = 200 \text{ days are required to}$$

finished the task by 25 workers.

Case-II.

Let 100 worker can finish the task in 50 days. 100 worker started completing the task by working for 10 days. Now to finish the task as soon as possible 100 more workers are employed. Now calculate the number of days required to complete the task.

Solution:

Here Man . Day = constant

$$100 \cdot 50 = 5000$$

initially 100 workers are working for 10 days so they can finish

$$100 \times 10 = 1000 \text{ (Man.Day)}$$

Now 4000 man - Day is still remaining which has to be finished by 200 workers

$$\text{So, } 200 \times \text{Day} = 4000$$

$$\text{Day} = \frac{4000}{200} = 20 \text{ days}$$

So total it requires $10 + 20 = 30$ days to complete the task.

Case-III.

Let 100 workers can finish the task in 50 days. 100 workers started the task and working for 20 days. Now because of unforeseen situations 80 workers have to left the work. Then find number of days required to complete the task.

Solution:

Here Man . Day = constant

$$100 \cdot 50 = 5000$$

initially 100 workers are working for 20 day so, they can finish

$$100 \times 20 = 2000 \text{ (Man . Day)}$$

Now, 3000 (Man . Day) is still remaining which has to be finished by 20 workers

$$\text{Man} \times \text{Day} = 3000$$

$$20 \times \text{Day} = 3000$$

$$\text{Day} = \frac{3000}{20} = 150 \text{ days}$$

so total it requires $20 + 150 = 170$ days to complete the task.

Man . Day . Hour

$$M_1 \cdot D_1 \cdot H_1 = \text{work, also}$$

$$M_2 \cdot D_2 \cdot H_2 = \text{work}$$

Work may be anything like construction of a wall of different size.

$$\frac{M_1 \cdot D_1 \cdot H_1}{W_1} = \frac{M_2 \cdot D_2 \cdot H_2}{W_2}$$

Also if $W_1 = l_1 b_1 h_1$ where length is l_1 breadth b_1 and height h_1 and if $w_2 = l_2 b_2 h_2$ where l_2 , b_2 and h_2 are length, and height respectively of second wall then

$$\frac{M_1 \cdot D_1 \cdot H_1}{l_1 b_1 h_1} = \frac{M_2 \cdot D_2 \cdot H_2}{l_2 b_2 h_2}$$

$$= \frac{l_1 b_1 h_1}{l_2 b_2 h_2} = \frac{M_1 \cdot D_1 \cdot H_1}{M_2 \cdot D_2 \cdot H_2}$$

Concept of Efficiency

Efficiency of persons performing same task may not be same. It may be different for different persons. If efficiency is high a person can complete the work much faster than stipulated time period. Similarly if efficiency is low, it requires more time to finish the same task than that of stipulated time.

We will observe following examples to have a glimpse of problems based on concept of efficiency.

Ex.1 A is twice as efficient as B, and finish the task 20 days earlier than B. Find number of days required to finish the task by A.

Sol.: Let A can complete the work in x days, then B requires $2x$ days to finish the same work.

According to given condition A finish the task 20 days earlier than B i.e. $2x - x = x \Rightarrow 20$ days.

So, A can finish the task in 20 days and B can finish the same task in 40 days.

Ex.2 A is three times as efficient as B and finish the task 32 days ahead of B. Find the number of days required to finish the task if both are working simultaneously.

Sol.: Let A requires x days then

B requires $3x$ days

$$3x - x = 2x \Rightarrow 32$$

$$x = 16 \text{ days}$$

$$x = 16 \quad 3x = 48 \text{ days}$$

Together they can finish

$$\frac{1}{16} + \frac{1}{48} = \frac{4}{48} \text{ part} = \frac{1}{12} \text{ part}$$

Thus 12 days are required by them to finish the task.

Ex.3 A is four times as efficient of B and can finish a task 45 days ahead of B. Find total number of days required to finish the task if both are working simultaneously.

Sol.: Let A requires x days then

B requires $4x$ days.

According to given condition

$$4x - x = 45 \Rightarrow 3x = 45 \Rightarrow x = 15.$$

Together they can finish

$$\frac{1}{15} + \frac{1}{60} = \frac{5}{60} = \frac{1}{12} \text{ part in a day}$$

So, it requires 12 days to finish the task together.

Ex.4 A is three times as efficient as B, and together they finish a task in 30 days. Find number of days required by B to finish the same task individually.

Sol.: Let A requires x days then
B requires $3x$ days
According to given condition

$$\frac{1}{x} + \frac{1}{3x} = \frac{1}{30}$$

$$\Rightarrow \frac{4}{3x} = \frac{1}{30}$$

$$\Rightarrow \frac{4 \times 30}{3} = x \Rightarrow x = 40$$

$$\therefore 3x = 120 \text{ Ans.}$$

Ex.5 A is thrice as efficient as B and can finish the task 16 days ahead of B. Find number of days required to finish the same task, if both are working alternately starting from A.

Sol.: Let A requires x days then
B requires $3x$ days
According to given condition

$$3x - x = 16 \Rightarrow 2x = 16$$

$$\Rightarrow x = 8$$

$$3x = 24$$

If they are working alternately then in two days they can finish

$$\frac{1}{8} + \frac{1}{24} \Rightarrow \frac{1}{6} \text{ part}$$

So it requires 12 days to finish the task.



SOLVED EXAMPLES

1. Vinod can do 25% of a piece of work in 5 days. How many days will he take to complete the work ten times?
(a) 150 days (b) 250 days
(c) 200 days (b) 180 days

Ans. (c)

25% part or $\frac{1}{4}$ part in 5 days

then 1 part in $\frac{5}{\frac{1}{4}} = 20$ days

days required to complete ten times work
= $20 \times 10 = 200$ days

2. 6 men can do piece of work in 12 days. How many men are needed to do the work in 18 days?

- (a) 3 men (b) 6 men
(c) 4 men (d) 2 men

Ans. (c)

Here Man . Day = $6 \times 12 = 72$

$$m \times 18 = 72, m = \frac{72}{18} = 4$$

3. A can do a piece of work in 20 days and B can do it in 15 days. How long will they take if both work together?

- (a) $8\left(\frac{6}{7}\right)$ days (b) $8\left(\frac{4}{7}\right)$ days

- (c) $9\left(\frac{3}{7}\right)$ days (d) None of these

Ans. (b)

Here $x = 20$ and $y = 15$ days required =

$$\frac{xy}{x+y} = \frac{20 \times 15}{20+15} = \frac{300}{35} = 8\frac{4}{7} \text{ days}$$

4. Nishu and Archana can do a piece of work in 10 days and Nishu alone can do it in 12 days. In How many days can Archana do it alone?

- (a) 60 days (b) 30 days
(c) 50 days (d) 45 days

Ans.(a)

$$\text{One day work of both} = \frac{1}{10}$$

and Nishu's day work = $\frac{1}{12}$

So, Archana's one day work

$$= \frac{1}{10} - \frac{1}{12} = \frac{2}{120} = \frac{1}{60}$$

So, 60 days required to finish the work by Archana

5. 4 men and 3 women finish a job in 6 days. And 5 men and 7 women can do the same job in 4 days. How long will 1 man and 1 woman take to do the work?

- (a) $22\left(\frac{2}{7}\right)$ days (b) $25\left(\frac{1}{2}\right)$ days
(c) $5\left(\frac{1}{7}\right)$ days (d) $12\left(\frac{7}{22}\right)$ days.

Ans. (a)

Let man completes m part in a day and woman completes w part in a day then

$$4m + 3w = \frac{1}{6} \quad \text{also} \quad (1)$$

$$5m + 7w = \frac{1}{4} \quad (2)$$

after simplifying we get

$$20m + 15w = \frac{5}{6}$$

$$20m + 28w = 1$$

$$\text{So } 13w = \frac{1}{6}$$

$$w = \frac{1}{78} \quad (3)$$

from (1) and (3) we get

$$m = \frac{5}{156}$$

$$m + w = \frac{5}{156} + \frac{1}{78} = \frac{7}{156}$$

$$\text{So it require } \frac{156}{7} \text{ days} = 22\frac{2}{7}$$

6. If 8 boys and 12 women can do a piece of work in 25 days. In how many days can the work be done by 6 boys and 11 women working together?

- (a) 15 days
(b) 10 days
(c) 12 days
(d) Cannot be determined

Ans. (d)

$$8B + 12w = \frac{1}{25} \quad (1)$$

now to calculate

$$6B + 11w = ?$$

It can not be determined because we have 1 equation but two variables.

7. A can do a piece of work in 10 days and B can do the same work in 20 days. With the help of C, they finish the work in 5 days. How long will it take for C alone to finish the work?

- (a) 20 days (b) 10 days
(c) 35 days (d) 15 days

Ans. (a)

$$\frac{1}{5} - \frac{1}{10} - \frac{1}{20} = \frac{1}{20}$$

This is C's one day work so 20 days are required for C alone to finish task

8. A can do a piece of work in 20 days. He works at it for 5 days and then B finishes it in 10 more days. In how many days will A and B together finish the work?

- (a) 8 days (b) 10 days
(c) 12 days (d) 6 days

Ans. (a)

$$\text{A's one day work} = \frac{1}{20}$$

$$\text{in 5 days A can complete } \frac{1}{20} \times 5 = \frac{1}{4} \text{ part}$$

$$\text{remaining work} = \frac{3}{4} \text{ part}$$

∴ B finish $\frac{3}{4}$ part in 10 days

∴ B finish 1 part in $\frac{10}{3/4} = \frac{40}{3}$ days

together they can finish it in

$$\frac{1}{\frac{1}{20} + \frac{3}{40}} = \frac{1}{\frac{1}{8}} = 8 \text{ days}$$

9. Twenty workers can finish a piece of work in 30 days. After how many days should 5 workers leave the job so that the work is completed in 35 days?

- (a) 5 days (b) 10 days
(c) 15 days (d) 20 days

Ans. (c)

$$\text{Man} \times \text{Day} = \text{Man} \cdot \text{Day}$$

$$20 \times 30 = 600$$

Let 5 workers leave after x days then

$$20x + 15(35 - x) = 600$$

$$5x + 525 = 600$$

$$5x = 75, x = 15$$

10. Subhash can copy 50 page in 10 hours; subhash and Prakash together can copy 300 pages in 40 hours. In how much time can Prakash copy 30 pages?

- (a) 13 h (b) 12 h
(c) 11 h (d) 9 h

Ans. (b)

∴ Subhash in 10 hours can copy 50 pages

∴ in 1 hour $\frac{50}{10} = 5$ pages

Both can copy 300 pages in 40 hours

$$\text{So, in 1h } \frac{300}{40} = 7.5$$

Clearly prakash can copy 2.5 pages in 1 hour

so 30 pages in $\frac{1}{2.5} \times 30 = 12$ hours

11. Sashi can do a piece of work in 25 days and Rishi can do it in 20 days. They work for 5 days and then Sashi goes away. In how many more days will Rishi finish the work?

- (a) 10 days (b) 12 days
(c) 14 days (d) None of these

Ans. (d)

$$\text{Shashi's days work} = \frac{1}{25}$$

$$\text{Rishi's days work} = \frac{1}{20}$$

together they can finish $\frac{1}{25} + \frac{1}{20}$

$$= \frac{9}{100} \text{ part in a day}$$

$$\therefore \text{Work in 5 days } \frac{9}{100} \times 5 = \frac{45}{100} \text{ part}$$

$\frac{55}{100}$ part is remaining. Rishi can finish it in

$$\frac{\left(\frac{55}{100}\right)}{\left(\frac{1}{20}\right)} = 11 \frac{1}{2} \text{ days}$$

12. Priya can do $\frac{1}{2}$ of the work in 8 days while Preeti can do $\frac{1}{3}$ of the work in 6 days. How long will it take for both of them to finish the work?

- (a) $\frac{88}{17}$ day (b) $\frac{144}{17}$ days

- (c) $\frac{72}{17}$ days (d) 8 days

Ans. (b)

$$\text{Priya's days work} = \frac{\left(\frac{1}{2}\right)}{8} = \frac{1}{16}$$

Preeti's days work

$$\Rightarrow \left(\frac{1}{3}\right) = \frac{1}{18} \text{ days}$$

Together they can finish in

$$\frac{1}{\frac{1}{16} + \frac{1}{18}} = \frac{144}{17} \text{ days}$$

13. Manoj takes twice as much time as Ajay and thrice as much as Vijay to finish a piece of work. Together they finish the work in 1 day. What is the time taken by Manoj to finish the work?

- (a) 6 days (b) 3 days
(c) 2 days (d) None of these

Ans. (a)

M : A : V

2 : 1 : 2/3 or 6 : 3 : 2

Let Manoj takes $6x$ days Ajay takes $3x$ days

and vijay $2x$ days then $\frac{1}{6x} + \frac{1}{3x} + \frac{1}{2x} = 1$

$$\frac{1}{x} \left[\frac{1}{6} + \frac{1}{3} + \frac{1}{2} \right] = 1$$

$$\frac{1}{x} = 1, \quad \text{So } x = 1$$

Manoj will take 6 days

14. Apurva can do a piece of work in 12 days. Apurva and Amit complete the work together and were paid Rs. 54 and Rs. 81 respectively. How many days must they have taken to complete the work together?

- (a) 4 days (b) 4.5 days
(c) 4.8 days (d) 5 days

Ans. (c)

Payment ratio = 54 : 81

$$\text{days work} = \frac{1}{12} : \frac{1}{x}$$

$$54 : 81 :: \frac{1}{12} : \frac{1}{x}$$

$$81 \times \frac{1}{12} = 54 \times \frac{1}{x}$$

$$x = \frac{54 \times 12}{81}, \quad x = 8 \text{ days}$$

together they will take = $\frac{12 \times 8}{12+8} = 4.8$ days.

15. Raju is twice as Vijay. Together, they finish the work in 14 days. In how many days can Vijay alone do the same work?

- (a) 16 days (b) 21 days
(c) 32 days (d) 42 days

Ans. (d)

Let Raju can do the work in x days then vijay in $2x$ days

together they can complete in

$$\frac{2x \times x}{3x} = 14 \text{ days}$$

$$x = 21 \text{ days}, \quad 2x = 42 \text{ days}$$

16. If 12 men and 16 boys can do a piece of work in 5 days and 13 men and 24 boys can do it in 4 days, compare the daily work done by a man with that done by a boy?

- (a) 1 : 2 (b) 1 : 3
(c) 2 : 1 (d) 3 : 1

Ans. (c)

$$12 M + 16 B = \frac{1}{5} \quad (1)$$

$$13 M + 24 B = \frac{1}{4} \quad (2) \text{ also}$$

$$36 M + 48 B = \frac{3}{5}$$

$$26 M + 48 B = \frac{2}{4}$$

$$10 M = \frac{1}{10}, \quad M = \frac{1}{100}$$

$$\text{from eq (1)} \quad B = \frac{1}{200}, \quad M : B = 1 : 2 : 1$$

17. A can do a work in 10 days and B can do the same work in 20 days. They work together for 5 days and then A goes away. In how many more days will B finish the work?

- (a) 5 days (b) 6.5 days
(c) 10 days (d) $8\frac{1}{3}$ days

Ans. (a)

In 5 days they can complete

$$\left[\frac{1}{10} + \frac{1}{20} \right] \times 5 = \frac{3}{4} \text{ part}$$

Remaining is $\frac{1}{4}$ part

B will finish it in $\frac{1}{\frac{1}{20}} = 20$ days

18. 15 men could finish a piece of work in 210 days. But at the end of 100 days, 15 additional men are employed. In how many more days will the work be complete?

- (a) 80 days (b) 60 days
(c) 55 days (d) 50 days

Ans. (c)

Man \times Day = Man . Day

15 . 210 = 3150 So after 100 days

15 . 100 = 1500 will be completed

remaining work = 1650 Man . Day

Man . Day = 1650

30 . Day = 1650

Day = 55

19. In a fort there was sufficient food for 200 soldiers for 31 day. After 27 days 120 soldiers left the fort. For how many extra days will the rest of the food last for the remaining soldiers?

- (a) 12 days (b) 10 days
(c) 8 days (d) 6 days

Ans. (b)

Man \times Day = Man . Day

200 \times 31 = 6200

After 27 days

200 \times 27 = 5400 Man .

Day is finished

remaining = 800

Man . Day = 800

80 . Day = 800

Day = 10

20. A cistern is normally filled in 5 hours. However, it takes 6 hours when there is leak in its bottom. If the cistern is full, in what time shall the leak empty it?

- (a) 6 h (b) 5 h
(c) 30 h (d) 15 h

Ans. (c)

In one hour $\frac{1}{5}$ part is filled now leak can empty in x hour then

$$\frac{1}{5} - \frac{1}{x} = \frac{1}{6}$$

$$\Rightarrow \frac{1}{5} - \frac{1}{6} = \frac{1}{x}$$

$$\Rightarrow \frac{1}{30} = \frac{1}{x}, x = 30 \text{ hours}$$

21. Pipe A and B running together can fill a cistern in 6 minutes. If B takes 5 minutes more than A to fill the cistern, then the time in which A and B will fill the cistern separately will be respectively?

- (a) 15 min, 20 min (b) 15 min, 10 min
(c) 10 min, 15 min (d) 25 min, 20 min

Ans. (c)

Let pipe A can fill in x and pipe B in x+5 minutes

$$\frac{1}{x} + \frac{1}{x+5} = \frac{1}{6}$$

$$\text{or } \frac{x(x+5)}{2x+5} = 6$$

$$x = 10, x + 5 = 15$$

22. A cistern is normally filled in 6 h but takes 4 h longer to fill because of a leak in its bottom. If the cistern is full, the leak will empty it in how much time?

- (a) 15 h (b) 16 h
(c) 20 h (d) None of these

Ans. (a)

Let leak empty in x hours Now

$$\frac{1}{6} - \frac{1}{x} = \frac{1}{10}$$

$$\frac{1}{6} - \frac{1}{10} = \frac{1}{x}$$

$$x = 15$$

23. If three taps are open together, a tank is filled in 10 h. One of the taps can fill in 5 h and another in 10 h. At what rate does the 3rd pipe work?

- (a) Waste pipe emptying the tank in 10 h
(b) Waste pipe emptying the tank in 20 h
(c) Waste pipe emptying the tank in 5 h
(d) Fills the tank in 10 h

Ans. (c)

$$\frac{1}{5} + \frac{1}{10} + \frac{1}{x} = \frac{1}{10}$$

$$\frac{1}{x} = \frac{-1}{5}$$

i.e. pipe can empty in 5 hours

24. There are two pipe in a tank. Pipe A is for filling the tank and Pipe B is for emptying the tank. If A can fill the tank in 10 hours and B can empty the tank in 15 hours then find how many hours will it take to completely fill a half empty tank?

- (a) 30 hours (b) 15 hours
(c) 20 hours (d) 33.33 hours

Ans. (b)

$$\frac{1}{10} - \frac{1}{15} = \frac{5}{150} = \frac{1}{30}$$

So it takes 30 hours to fill the tank and 15 hours to fill half the tank

25. There are three Taps A, B and C in a tank. They can fill the tank in 10 hrs, 20 hrs and 25 hrs respectively. At first, all of them are opened simultaneously. Then after 2 hours tap C is closed and A and B are kept running. After the 4th hour, tap B is also closed. The remaining work is done by Tap A alone. Find the percentage of the work done by Tap A by itself.

- (a) 32 % (b) 52 %
(c) 75 % (d) None of these

Ans. (d)

	A	B	C		
I st hours	$\frac{1}{10}$	$\frac{1}{20}$	$\frac{1}{25}$	$\frac{19}{100}$ part	
II nd hours	$\frac{1}{10}$	$\frac{1}{20}$	$\frac{1}{25}$	$\frac{19}{100}$ part	
III rd hours	$\frac{1}{10}$	$\frac{1}{20}$	x	$\frac{3}{20}$	$\frac{15}{100}$ part
IV th hours	$\frac{1}{10}$	$+\frac{1}{20}$	x	$\frac{3}{20}$	$\frac{15}{100}$ part

So remaining part after 4 hour is

$$\frac{32}{100} = 3.2 \text{ hours}$$

$$\frac{1}{10}$$

% of work done by A

$$\frac{(10 + 10 + 10 + 10 + 32)}{100} \times 100 = 72\%$$

□□□□

Time & Work



Practice Exercise: I

1. 10 men can complete a piece of work in 15 days and 15 women can complete the same work in 12 days. If all the 10 men and

- 15 women work together, in how many will the work get completed?
- (a) $6\frac{2}{3}$ days (b) $8\frac{1}{3}$ days
- (c) $7\frac{2}{3}$ days (d) None of these
2. A can do $\frac{1}{3}$ of a work in 5 days and B can do $\frac{2}{5}$ of the work in 10 days. In how many days both A and B together can do the work?
- (a) $13\frac{2}{3}$ days (b) $9\frac{3}{8}$ days
- (c) $18\frac{5}{8}$ days (d) None of these
3. A is thrice as good as B and is therefore able to finish a piece of work in 60 days less than B. Find the time in which they can do it, working together.
- (a) $22\frac{3}{4}$ days (b) $22\frac{1}{2}$ days
- (c) 24 days (d) None of these
4. Ramesh takes twice as much time as Mahesh and thrice as much time as Suresh to complete a job. If working together, they can complete the job in 4 days, then the time taken by each of them separately to complete the work is
- (a) 36, 24 and 16 days
- (b) 20, 16 and 12 days
- (c) 24, 42 and 18 days
- (d) None of these
5. 5 men can complete a work in 2 days, 4 women can complete the same work in 3 days and 5 children can do it in 3 days. 1 man, 1 woman and 1 child, working together, can complete the work in
- (a) 6 days (b) 4 days
- (c) 8 days (d) None of these
6. A and B can finish a piece of work in 30 days, B and C in 40 days while C and A in 60 days. A, B, C together can do the work in
- (a) $24\frac{3}{4}$ days (b) $28\frac{2}{3}$ days
- (c) $26\frac{2}{3}$ days (d) None of these
7. Ajay and Sunil can do a piece of work in 10 days, sunil and Sanjay in 15 days and Sanjay and Ajay in 20 days. They together work at it for 6 days and then Ajay leaves and Sunil and Sanjay go on together for 4 days more. If Sunil then leaves, how long will Sanjay take to complete the work?
- (a) 12 days (b) 10 days
- (c) 16 days (d) None of these
8. Bansal, Gupta and Singhal together can complete a work in 4 days. If Bansal and Gupta together can complete the work in $4\frac{4}{5}$ days, Gupta and Singhal together can do it in 8 days, then Gupta alone can complete the work in
- (a) 16 days (b) 12 days
- (c) 20 days (d) None of these
9. Bindal can finish a work in 10 days. Jindal is twice as efficient as Bindal. If they work together, in how many days, the work will be finished?
- (a) $3\frac{1}{3}$ days (b) $5\frac{2}{3}$ days
- (c) $4\frac{1}{3}$ days (d) None of these
10. A is 4 times as fast as B and is therefore able to finish a work in 45 days less than B. A and B, working together, can complete the work in
- (a) 12 days (b) 16 days
- (c) 8 days (d) None of these

11. Working 7 hours daily 24 men can complete a piece of work in 27 days. In how many days would 14 men complete the same piece of work working 9 hours daily?
 (a) 36 days (b) 30 days
 (c) 32 days (d) None of these
12. 45 men complete a piece of work in 30 days working 12 hours a day. In how many days will 60 men complete the work working 10 hours a day?
 (a) 27 days (b) 30 days
 (d) 24 days (d) None of these
13. 4 men or 6 women can finish a piece of work in 20 days. In how many days can 6 men and 11 women finish the same work?
 (a) 9 days (b) 6 days
 (c) 7 days (d) None of these
14. A can do a piece of work in 10 days, while B alone can do it in 15 days. They work together for 5 days and the rest of the work is done by C in 2 days. If they get Rs. 450 for the whole work, how should they divide the money?
 (a) Rs. 250, Rs. 100, Rs. 100
 (b) Rs. 225, Rs. 150, Rs. 75
 (c) Rs. 200, Rs. 150, Rs. 100
 (d) Rs. 175, Rs. 175, Rs. 100
15. A does half as much work as B in three-fourths of the time. If together they take 18 days to complete a work, how much time shall B take to do it?
 (a) 30 days (b) 35 days
 (c) 40 days (d) 66
16. Two men undertake to do a piece of work for Rs. 600. One alone could do it in 6 days and the other in 8 days. With the assistance of a boy they finish it in 3 days. Boy's share should be
 (a) Rs. 300 (b) Rs. 225
 (c) Rs. 75 (d) Rs. 100
17. 5 men and 2 boys working together can do four times as much work per hour as a man and a boy together. The work done by a man and a boy should be in the ratio
 (a) 1 : 2 (b) 2 : 1
 (c) 1 : 3 (d) 4 : 1
18. A and B working separately can do a piece of work in 9 and 12 days, respectively. If they work for a day alternately, A beginning, in how many days the work will be completed?
 (a) $10\frac{1}{2}$ days (b) $10\frac{1}{4}$ days
 (c) $10\frac{2}{3}$ days (d) $10\frac{1}{2}$ days
19. A and B can do a piece of work in 45 and 40 days, respectively. They began the work together, but A leaves after some days and B finished the remaining work in 23 days. After how many days, did A leaves?
 (a) 6 days (b) 8 days
 (c) 9 days (d) 12 days
20. A can do a piece of work in 30 days, B in 50 days and C in 40 days. If A is assisted by B on one day and by C on the next day alternately work will be completed in
 (a) $17\frac{32}{35}$ days (b) $19\frac{2}{3}$ days
 (c) $16\frac{31}{37}$ days (d) $18\frac{1}{3}$ days

Solutions

1. Ans. (a)

Here, $x = 15$ and $y = 12$

∴ Working together, 10 men and 15 women will complete the work in

$$= \frac{xy}{x+y} \text{ days}$$

$$= \frac{15 \times 12}{15 + 12}, \text{ i.e. } \frac{20}{3} \text{ or, } 6\frac{2}{3} \text{ days.}$$

2. Ans. (b)

A can do the complete work in $5 \times 3 = 15$ days

B can do the complete work in $= 10 \times \frac{5}{2}$

$= 25$ days. Here, $x = 15$ and $y = 25$.

\therefore A and B working together, can complete

the work in $\frac{xy}{x+y}$ days

$$\Rightarrow \frac{15 \times 25}{15 + 25} \text{ days i.e. } \frac{75}{8} \text{ or } 9\frac{3}{8} \text{ days}$$

3. Ans. (b)

Let B takes x days to do the work. Then, A takes $(x - 60)$ days to complete the work. Since ratio of work done by A and B is 3 : 1, ratio of time taken by A and B is 1 : 3.

$$\text{We have, } \frac{x - 60}{x} = \frac{1}{3}$$

$$\Rightarrow 3(x - 60) = x \text{ or, } x = 90.$$

\therefore Time taken by B to finish the work = 90 days and time taken by A to finish the

$$\text{work} = \frac{90}{3} = 30 \text{ days.}$$

\therefore A and B, working together, will complete

the work in $\frac{xy}{x+y}$ days

$$= \frac{90 \times 30}{90 + 30} \text{ days, i.e. } \frac{45}{2}$$

or, $22\frac{1}{2}$ days.

4. Ans. (d)

Let Ramesh takes x days to finish the work.

Then, Mahesh takes $\frac{x}{2}$ and Suresh takes $\frac{x}{3}$

days to finish the same work.

\therefore Ramesh, Mahesh and Suresh, working together, will complete the work in

$$\frac{xyz}{xy + yz + zx} \text{ day}$$

$$= \frac{x + \frac{x}{2} \times \frac{x}{3}}{x \times \frac{x}{2} + \frac{x}{2} \times \frac{x}{3} + x \times \frac{x}{3}} \text{ days}$$

$$\text{i.e. } \frac{x^3/6}{x^2} \text{ or, } \frac{x}{6} \text{ days}$$

$$\text{Given : } \frac{x}{6} = 4. \therefore x = 24$$

\therefore Ramesh takes 24 days. Mahesh takes

$$\frac{24}{2} \text{ or } 12 \text{ days and Suresh takes } \frac{24}{3}$$

= 8 days to finish the work.

5. Ans. (b)

1 Man can complete the work in $5 \times 2 = 10$ days, 1 woman can complete the work in $4 \times 3 = 12$ days. And 1 child can complete the work in $5 \times 3 = 15$ days.

\therefore 1 man, 1 woman and 1 child, working together, can complete the work in

$$\frac{xyz}{xy + yz + zx} \text{ days}$$

$$= \frac{10 \times 12 \times 15}{10 \times 12 + 12 \times 15 + 15 \times 10} = 4 \text{ days}$$

6. Ans. (c)

Here, $x = 30$, $y = 40$ and $z = 60$.

\therefore A, B and C together will finish the work in

$$= \left(\frac{2xyz}{xy + yz + zx} \right) \text{ days}$$

$$= \left(\frac{2 \times 30 \times 40 \times 60}{30 \times 40 + 40 \times 60 + 60 \times 30} \right) \text{ days}$$

or, $\frac{144000}{5400}$, i.e. $26\frac{2}{3}$ days

7. Ans. (b)

Ajay, sunil and Sanjay, working together, can complete the work in

$$= \left(\frac{2xyz}{xy + yz + zx} \right) \text{ days}$$

$$= \left(\frac{2 \times 10 \times 15 \times 20}{10 \times 15 + 15 \times 20 + 20 \times 10} \right)$$

$$\frac{6000}{650}, \text{ i.e. } \frac{120}{13} \text{ days}$$

∴ Work done by all of them together in

$$6 \text{ days} = \frac{6 \times 13}{120} \text{ i.e. } \frac{13}{20}$$

Also, work done by Sunil and Sanjay in 4

$$\text{days} = \frac{4}{15}$$

∴ Remaining work

$$= 1 - \left(\frac{13}{20} + \frac{4}{15} \right) = \frac{1}{12}$$

Which is to be done by Sanjay.

Now, Ajay Sunil and Sanjay, can complete

the work in $\frac{120}{13}$ days and Ajay and Sunil

can complete the work in 10 days.

∴ Sanjay alone can complete the work in

$$\frac{\frac{120}{13} \times 10}{10 - \frac{120}{13}} = 120 \text{ days.}$$

∴ $\frac{1}{12}$ of the work is done by Sanjay in $\frac{120}{12}$
= 10 days.

8. Ans. (b)

Bansal, Gupta and Singhal together can finish the work in 4 days.

Bansal and Gupta together can do it in

$\frac{24}{5}$ days. Gupta and Singhal together can do

it in 8 days. Therefore, Bansal alone can complete the work in

$$= \frac{xy}{y-x} \text{ days} = \left(\frac{8 \times 4}{8-4} \right) \text{ days}$$

[Here, $x = 4$ and $y = 8$ days

Also, Singhal alone can complete the work in

$$= \left(\frac{xy}{x-y} \right) \text{ days} = \left(\frac{\frac{24}{5} \times 4}{\frac{24}{5} - 4} \right) \text{ days}$$

Here, $x = 4$ and $y = \frac{24}{5} = 24$ days.

∴ Bansal and Singhal can complete the work in

$$= \left(\frac{xy}{x+y} \right) \text{ days} = \left(\frac{24 \times 8}{24 + 8} \right) \text{ days}$$

[Here $x = 24$ and $y = 8$] = 6 days.

Gupta alone can complete the work

$$\frac{6 \times 4}{6-4} = 12.$$

9. Ans. (a)

Here, $x = 10$ and $k = 2$.

∴ The time taken by Bindal and Jindal.

Working together, to complete the work

$$= \frac{x}{1+k} = \frac{10}{1+2}, \text{ i.e. } \frac{10}{3} \text{ or, } 3\frac{1}{3} \text{ days}$$

10. Ans. (a)

Here, $k = 4$ and $l = 45$.

Therefore, A and B, working together, can complete the work in

$$= \frac{kI}{k^2 - 1} \text{ days} = \frac{4 \times 45}{16 - 1} \text{ days,}$$

i.e. 12 days.

11. Ans. (a)

$$\text{We have } M_1 = 24, D_1 = 27, W_1 = 1, t_1 = 7,$$

$$M_2 = 14, D_2 = ?, W_2 = 1, t_2 = 9,$$

$$M_1 D_1 t_1 W_2 = M_2 D_2 t_2 W_1$$

$$\Rightarrow 24 \times 27 \times 7 \times 1 = 14 \times D_2 \times 9 \times 1$$

$$\Rightarrow D_2 = 36 \text{ days.}$$

12. Ans. (a)

$$\text{We have, } M_1 = 45, D_1 = 30, t_1 = 12, W_1 = 1,$$

$$M_2 = 60, D_2 = ? t_2 = 10, W_2 = 1$$

$$\Rightarrow 45 \times 30 \times 12 \times 1 = 60 \times D_2 \times 10 \times 1$$

$$\Rightarrow D_2 = 27 \text{ days}$$

13. Ans. (b)

Here, $a = 4, b = 6, n = 20, c = -6,$
and $d = 11.$

∴ Required number of days

$$= \left(\frac{nab}{bc + ad} \right) \text{ days}$$

$$= \left(\frac{20 \times 4 \times 6}{6 \times 6 + 4 \times 11} \right) \text{ days} = 6 \text{ days.}$$

14. Ans. (b)

$$(A+B)\text{'s 5 day's work} = 5 \left(\frac{1}{10} + \frac{1}{15} \right) = \frac{5}{6}$$

$$\text{Remaining work} = 1 - \frac{5}{6} = \frac{1}{6}$$

$$\therefore \text{C's 2 days' work} = \frac{1}{6}$$

Now A's 5 days' work : B's 5 days' work

$$\therefore \text{C's 2 days' work} = \frac{5}{10} : \frac{5}{15} : \frac{1}{6} = 3 : 2 : 1$$

$$\therefore \text{A's share} = \text{Rs} \left(450 \times \frac{3}{6} \right) = \text{Rs. } 225$$

$$\text{B's share} = \left(450 \times \frac{2}{6} \right) = \text{Rs. } 150$$

$$\text{C's share} = \text{Rs.} [450 - (225 + 150)] \\ = \text{Rs. } 75$$

15. Ans. (d)

If B does x part of work in 1 hour

then B does $\frac{3}{4}x$ part $\frac{3}{4}$ hour

Now, A does $\frac{3x}{8}$ work in 1 hour

$$\text{It is given that } x + \frac{3}{8}x = \frac{1}{18}$$

$$\text{So } x = \frac{4}{99}$$

B complete work in $\frac{99}{4}$ days and A in 66 days.

16. Ans. (c)

$$\text{1st man's 3 days' work} = \frac{3}{6} = \frac{1}{2}$$

$$\text{2nd man's 3 days' work} = \frac{3}{8}$$

$$\text{Boy's 3 days' work} = 1 - \left(\frac{1}{2} + \frac{3}{8} \right) = \frac{1}{8}$$

∴ They should get money in the ratio

$$\frac{1}{2} : \frac{3}{8} : \frac{1}{8} \text{ i.e. } 4 : 3 : 1$$

$$\therefore \text{Boy's share} = \text{Rs. } \frac{1}{8} \times 600 = \text{Rs. } 75.$$

17. Ans. (b)

Obviously,

$$(5M + 2B) = 4(1M + 1B)$$

$$\therefore M = 2B$$

\therefore Work done by a man and boy are in the ratio 2 : 1

18. Ans. (b)

(A + B)'s 2 days' work $\frac{1}{9} + \frac{1}{7} = \frac{7}{36}$ Evidently,

the work done by A and B during 5 pairs of

$$\text{days} = 5 \times \frac{7}{36} = \frac{35}{36}$$

$$\text{Remaining work} = 1 - \frac{35}{36} = \frac{1}{36}$$

Now, $\frac{1}{9}$ work is done by A in 1 day

$\therefore \frac{1}{36}$ work, will be done by A in

$$9 \times \frac{1}{36} = \frac{1}{4} \text{ day}$$

So, total time taken = $10\frac{1}{4}$ days.

19. Ans. (c)

$$\text{B's 23 days' work} = \frac{23}{40}$$

$$\text{Remaining work} = 1 - \frac{23}{40} = \frac{17}{40}$$

Now, (A+B)'s 1 day's work

$$= \frac{1}{45} + \frac{1}{40} = \frac{17}{360}$$

$\frac{17}{360}$ work is done by A and B in 1 day

$\therefore \frac{17}{40}$ work is done by A and B in

$$\frac{360 \times 17}{17 \times 40} = 9 \text{ days}$$

so, A left after 9 days.

20. Ans. (a)

$$(A+B)\text{'s 1 day's work} = \frac{1}{30} + \frac{1}{50} = \frac{8}{150}$$

\therefore (A + C)'s 1 day's work

$$= \frac{1}{30} + \frac{1}{40} = \frac{7}{120}$$

\therefore Work done in first 2 days

$$= \frac{8}{150} + \frac{7}{120} = \frac{67}{600}$$

Work done in $8 \times 2 = 16$ days

$$= \frac{67 \times 8}{600} = \frac{67}{75}$$

$$\text{Work left} = 1 - \frac{67}{75} = \frac{8}{75}$$

On 17th day (A + B) will work and they will

finish $\frac{8}{150}$

$$\therefore \text{Work left} = \frac{8}{75} - \frac{8}{150} = \frac{8}{150} = \frac{4}{75}$$

On 18th day (A + C) will work and they

will finish it in $\frac{120}{7} \times \frac{4}{75} = \frac{32}{35}$ days

\therefore Whole work will be done in $17\frac{32}{35}$ days

□□□□

Pipes & Cisterns



Practice Exercise: I

- One tap can fill a cistern in 2 hours and another can empty the cistern in 3 hours. How long will they take to fill the cistern if both the taps are opened?
 - 6 hours
 - 7 hours
 - 6.30 hours
 - None of these
- A tap can fill a tank in 25 minutes and another can empty it in 50 minutes. Find whether the tank will be filled up or emptied and in how many minutes?
 - Tank is filled up in 50 minutes
 - Tank is emptied in 25 minutes
 - Tank is filled up in 25 minutes
 - None of these
- Two taps A and B can fill a tank in 10 hours and 15 hours, respectively. If both the taps are opened together the tank will be full in:
 - 8 hours
 - 6 hours
 - 5 hours
 - None of these
- Two pipes can fill a tank in 10 hours and 12 hours, respectively. While a third pipe emptied the full tank in 20 hours. If all the three pipes operate simultaneously, in how much time the tank will be filled?
 - 7 hours 30 minutes
 - 6 hours 40 minutes
 - 8 hours 30 minutes
 - None of these
- A cistern is normally filled in 8 hours but takes 2 hours longer to fill because of a leak in its bottom. If the cistern is full, the leak will empty it in
 - 35 hours
 - 45 hours
 - 40 hours
 - None of these
- If two pipes function simultaneously, the reservoir will be filled in 12 hours. One pipe fills the reservoir 10 hours faster than the other. How many hours does the faster pipe take to fill the reservoir?
 - 35 hours
 - 30 hours
 - 40 hours
 - None of these
- One fill pipe A is 3 times faster than second fill pipe B and takes 32 minutes less than the fill pipe B. When will the cistern be full if both pipes are opened together?
 - 28 minutes
 - 24 minutes
 - 30 minutes
 - data inadequate
- Two pipes A and B can fill a cistern in 4 minutes and 6 minutes, respectively. If these pipes are turned on alternately for 1 minute each how long will it take for the cistern to fill?
 - 4 min 40 sec
 - 3 min 20 sec
 - 4 min 50 sec
 - 3 min 30 sec
- A cistern is provided by two taps A and B. A can fill it in 20 minutes and B in 25 taps minutes. Both the taps are kept open for 5 minutes and then the second is turned off. The cistern will be completely filled in another
 - 11 minutes
 - 10 minutes
 - 15 minutes
 - 12 minutes
- A cistern has two taps which fill it in 12 minutes and 15 minutes respectively. There is also a waste pipe in the cistern. When all the pipes are opened, the empty cistern is full 20 minutes. How long will the waste pipe take to empty a full cistern?
 - 8 minutes
 - 10 minutes
 - 12 minutes
 - 16 minutes

Solutions

- Ans. (a)
Here, $x = 2$ and $y = 3$
 \therefore Part of the cistern filled in 1 hour

$$= \frac{1}{x} - \frac{1}{y} = \frac{1}{2} - \frac{1}{3} = \frac{1}{6}$$

∴ Total time taken to fill the cistern = 6 hrs.

2. Ans. (a)

Here, $x = 25$ and $y = 50$

∴ Part of the tank filled or emptied in 1 minutes

$$= \frac{1}{x} - \frac{1}{y} = \frac{1}{25} - \frac{1}{50} = \frac{1}{50}$$

Which is positive, therefore the tank will be filled.

∴ Total time taken to fill the tank = 50 minutes

3. Ans. (b)

Here, $x = 10$ and $y = 15$.

∴ The tank will be full in

$$= \left(\frac{xy}{x+y} \right) \text{ hours}$$

$$= \left(\frac{10 \times 15}{10+15} \right) \text{ hours or 6 hours.}$$

4. Ans. (a)

Here, $x = 10$, $y = 12$ and $z = -20$

∴ The tank will be full in

$$= \left(\frac{x \times y \times z}{xy - yz - zx} \right) \text{ hours}$$

$$= \left(\frac{10 \times 12 \times -20}{10 \times 12 - 12 \times 20 - 20 \times 10} \right) \text{ hours}$$

$$= \left(\frac{15}{2} \right) \text{ hours or, 7 hours 30 minutes}$$

5. Ans. (c)

Here, $x = 8$ and $y = 8 + 2 = 10$.

∴ The leak will empty the cistern in

$$= \left(\frac{xy}{y-x} \right) \text{ hours}$$

$$= \left(\frac{8 \times 10}{10-8} \right) \text{ hours or, 40 hours}$$

6. Ans. (b)

Let one pipe take x hours to fill the reservoirs.

Then, another pipe takes $(x - 10)$ hours.

$$\therefore \frac{1}{x} + \frac{1}{x-10} = \frac{1}{12}$$

$$\Rightarrow x(x-10) = 12(x+x-10)$$

$$\Rightarrow x^2 - 34x + 120 = 0$$

$$\text{or } (x-30)(x-4) = 0$$

$$\therefore x = 30 \text{ or } x = 4$$

∴ The faster pipe takes 30 hours to fill the reservoir.

7. Ans. (b)

Here, $k = 3$ and $x = 32$

$$\therefore \text{Cistern will be full in} = \frac{kx}{(k-1)^2} \text{ minutes}$$

$$= \frac{3 \times 32}{(3-1)^2} \text{ minutes} = 24 \text{ minutes}$$

8. Ans. (a)

As the pipes are operating alternately, thus

$$\text{their 2 minutes job is } \frac{1}{4} + \frac{1}{6} = \frac{5}{12}$$

In the next 2 minutes the pipes can fill another

$\frac{5}{12}$ part of cistern. Therefore, in 4 minutes

the two pipes which are operating alternately

$$\text{will fill } \frac{5}{12} + \frac{5}{12} = \frac{10}{12} = \frac{5}{6} \text{ part.}$$

$$\text{The part of the cistern left unfilled} = 1 - \frac{5}{6} = \frac{1}{6}$$

Pipe A can fill $\frac{1}{4}$ of the cistern in 1 minutes.

Pipe A can fill $\frac{1}{6}$ of the cistern in

$$4 \times \frac{1}{6} = \frac{2}{3} \text{ minutes}$$

Total time taken to fill the cistern

$$4 + \frac{2}{3} = 4\frac{2}{3} \text{ min.}$$

Or, 4 minutes 40 seconds.

9. Ans. (a)

$$\text{Part filled in 1 minute} = \frac{1}{20} + \frac{1}{25} = \frac{9}{100}$$

$$\text{Part filled in 5 minutes} = \frac{9}{100} \times 5 = \frac{9}{20}$$

$$\text{Unfilled part} = 1 - \frac{9}{20} = \frac{11}{20}$$

This is to be filled by A alone and hence will

$$\text{be filled in } 20 \times \frac{11}{20} = 11 \text{ minutes.}$$

10. Ans. (b)

Work done by waste pipe in 1 minutes

$$= \left(\frac{1}{12} + \frac{1}{15} \right) - \frac{1}{20}$$

$$= \left(\frac{3}{20} - \frac{1}{20} \right) = \frac{1}{10}$$

∴ Waste pipe can empty the cistern in 10 minutes.



Pipes & Cisterns



Practice Exercise: II

- Two taps A and B can fill a tank in 10 hours and 15 hours respectively. If both the taps are opened together, the tank will be full in:
 - 5 hrs.
 - 6 hrs.
 - $12\frac{1}{2}$ hrs
 - $7\frac{1}{2}$ hrs.
- Two pipes can fill a tank in 10 hours and 12 hours respectively while a third pipe empties the full tank in 20 hours. If all the three pipes operate simultaneously, in how much time the tank will be filled?
 - 7 hrs
 - 8 hrs
 - 7 hrs 30 min.
 - 8 hrs 30 min.
- An electric pump can fill a tank in 3 hours. Because of a leak in the tank, it took $3\frac{1}{2}$ hours to fill the tank. The leak can drain out all the water of the tank in:
 - $10\frac{1}{2}$ hrs
 - 12 hrs
 - 21 hrs.
 - 24 hrs
- Taps A and B can fill a bucket in 12 minutes and 15 minutes respectively. If both are opened and A is closed after 3 minutes, how much further time would it take for B to fill the bucket?
 - 7 min. 45 sec
 - 7 min 15 sec
 - 8 min. 5 sec
 - 8 min 15 sec
- If two pipes function simultaneously, the reservoir will be filled in 12 hours. One pipe fills the reservoir 10 hours faster than the other. How many hours it takes the second pipes to fill the reservoir?
 - 25 hrs
 - 28 hrs
 - 30 hrs
 - 35 hrs

6. 12 buckets of water fill a tank when the capacity of each bucket is 13.5 liters. How many buckets will be needed to fill the same tank, if the capacity of each bucket is 9 liters?
 (a) 8 (b) 16
 (c) 15 (d) 18
7. Bucket P has thrice the capacity as bucket Q. It takes 60 turns for bucket P to fill the empty drum. How many turns it will take for both the buckets P and Q, having each turn together to fill the empty drum?
 (a) 30 (b) 40
 (c) 45 (d) 90
8. Two pipes A and B can fill a cistern in 12 minutes and 15 minutes respectively but a third pipe C can empty the full tank in 6 minutes, A and B are kept open for 5 minutes in the beginning and then C is also opened. In what time is the cistern emptied?
 (a) 30 min. (b) 33 min.
 (c) $37\frac{1}{2}$ min. (d) 45 min.
9. Three pipes A, B and C can fill a tank in 6 hours. After working at it together for 2 hours, C is closed and A and B can fill the remaining part in 7 hours. The number of hours taken by C alone to fill the cistern, is:
 (a) 10 (b) 12
 (c) 14 (d) 16
10. A leak in the bottom of tank can empty the full tank in 8 hours. An inlet pipe fills water at the rate of 6 liters a minute. When the tank is full, the inlet is opened and due to the leak, the tank is empty in 12 hours. How many liters does the cistern hold?
 (a) 7580 (b) 7960
 (c) 8290 (d) 8640
11. A cistern has two taps which fill it in 12 min. and 15 min, respectively. There is also a waste pipe in the cistern. When all the three are

opened, the empty cistern is full in 20 minutes. How long will the waste pipe take to empty the full cistern?

- (a) 8 min (b) 10 min
 (c) 12 min (d) 16 min

12. Two pipes A and B can fill a cistern in 12 minutes and 16 minutes respectively. If both the pipes are opened together, then after how much time B should be closed so that the tank is full in 9 minutes?

- (a) $3\frac{1}{2}$ min. (b) 4 min
 (c) $4\frac{1}{2}$ min (d) $4\frac{3}{4}$ min.

Solutions

1. Ans. (b)

$$A's\ 1\ hour's\ work = \frac{1}{2},\ B's\ hour's\ work = \frac{1}{15}$$

(A + B)'s 1 hour's work

$$= \left(\frac{1}{10} + \frac{1}{15} \right) = \frac{5}{30} = \frac{1}{6}$$

∴ Both the taps can fill the tank in 6 hours.

2. Ans. (c)

Net part filled in 1 hour

$$= \left(\frac{1}{10} + \frac{1}{12} - \frac{1}{20} \right) = \frac{8}{60} = \frac{2}{15}$$

∴ The tank will be full in $\frac{15}{2}$ hrs.

= 7 hrs. 30 min.

3. Ans. (c)

Work done by the leak in 1 hour

$$= \left(\frac{1}{3} - \frac{2}{7} \right) = \frac{1}{21}$$

∴ Leak will empty the tank in 21 hours.

4. Ans. (d)

Part filled in 3 min:

$$= 3 \left(\frac{1}{12} + \frac{1}{15} \right) = \left(3 \times \frac{9}{60} \right) = \frac{9}{20}$$

$$\text{Remaining part} = \left(1 - \frac{9}{20} \right) = \frac{11}{20}$$

$$\text{Part filled by B in 1 min.} = \frac{1}{15}$$

$$\frac{1}{15} : \frac{11}{20} = 1 : x \text{ or } x = \left(\frac{11}{20} \times 1 \times \frac{15}{1} \right)$$

= 8 min. 15 sec

∴ Remaining part is filled by B in 8 min. 15 sec.

5. Ans. (c)

Let the reservoir be filled by first pipe in x hours. The second pipe will fill it in $(x+10)$ hours.

$$\therefore \frac{1}{x} + \frac{1}{x+10} = \frac{1}{12} \Leftrightarrow \frac{x+10+x}{x(x+10)} = \frac{1}{12}$$

$$\Rightarrow x^2 - 14x - 120 = 0$$

$$\Rightarrow (x-20)(x+6) = 0 \Rightarrow x = 20$$

∴ Second pipe takes 30 hrs to fill the reservoir.

6. Ans. (d)

Capacity of the tank = (12×13.5) litres
= 162 litres.

Capacity of each bucket = 9 litres

$$\text{Number of buckets needed} = \left(\frac{162}{9} \right) = 18$$

7. Ans. (c)

Let capacity of P be x litres.

Then, capacity of Q = $\frac{x}{3}$ litres.

Capacity of the drum = $60x$ litres.

Required number of turns

$$= \frac{60}{\left(x + \frac{x}{3} \right)} = \left(60 \times \frac{3}{4x} \right) = 45.$$

8. Ans. (d)

Part filled in 5 min

$$= 5 \left(\frac{1}{12} + \frac{1}{15} \right) = \left(5 \times \frac{9}{60} \right) = \frac{3}{4}$$

Part emptied in 1 min., when all the pipes are opened

$$= \frac{1}{6} - \left(\frac{1}{12} + \frac{1}{15} \right) = \left(\frac{1}{6} - \frac{3}{20} \right) = \frac{1}{60}$$

Now, $\frac{1}{60}$ part is emptied in 1 min

$$\therefore \frac{3}{4} \text{ part will be emptied on } \left(60 \times \frac{3}{4} \right) = 45 \text{ min.}$$

9. Ans. (c)

$$\text{Part filled in 2 hours} = \frac{2}{6} = \frac{1}{3}$$

$$\text{Remaining part} = \left(1 - \frac{1}{3} \right) = \frac{2}{3}$$

$$\therefore (A+B)'s \text{ 7 hour's work} = 2/3$$

$$\therefore (A+B)'s \text{ 1 hour's work} = 2/21$$

$$\therefore C's \text{ 1 hour's work}$$

$$= [(A+B+C)'s \text{ 1 hour's work}] - (A+B)'s \text{ 1 hour's work}$$

$$\text{hour's work} = \left(\frac{1}{6} - \frac{2}{21} \right) = \frac{1}{14}$$

$$\therefore C \text{ alone can fill the tank in 14 hours.}$$

10. Ans. (d)

Work done by the main 1 hour

$$= \left(\frac{1}{8} - \frac{1}{12} \right) = \frac{1}{24}$$

Work done by the inlet in 1 min.

$$= \left(\frac{1}{24} \times \frac{1}{60} \right) = \frac{1}{1440}$$

∴ Volume of $\frac{1}{1440}$ part = 6 litres

∴ Volume of whole = (1440 × 6) litres
= 8640 litres

11. Ans. (b)

Work done by waste pipe in 1 min.

$$= \frac{1}{20} - \left(\frac{1}{12} + \frac{1}{15} \right) = -\frac{1}{10}$$

[-Ve sign means emptying]

∴ Waste pipe will empty the full cistern in
10 min.

12. Ans. (b)

Let B be closed after x minutes.

Then, Part filled by (A + B) in x min. + Part
filled by A in (9 - x) min. = 1

$$\therefore x \left(\frac{1}{12} + \frac{1}{16} \right) + (9 - x) \cdot \frac{1}{12} = 1$$

$$\text{or } \frac{7x}{48} + \frac{9-x}{12} = 1$$

$$\text{or } 7x + 36 - 4x = 48 \text{ or } x = 4.$$

So, B must be closed after 4 minutes

□□□□

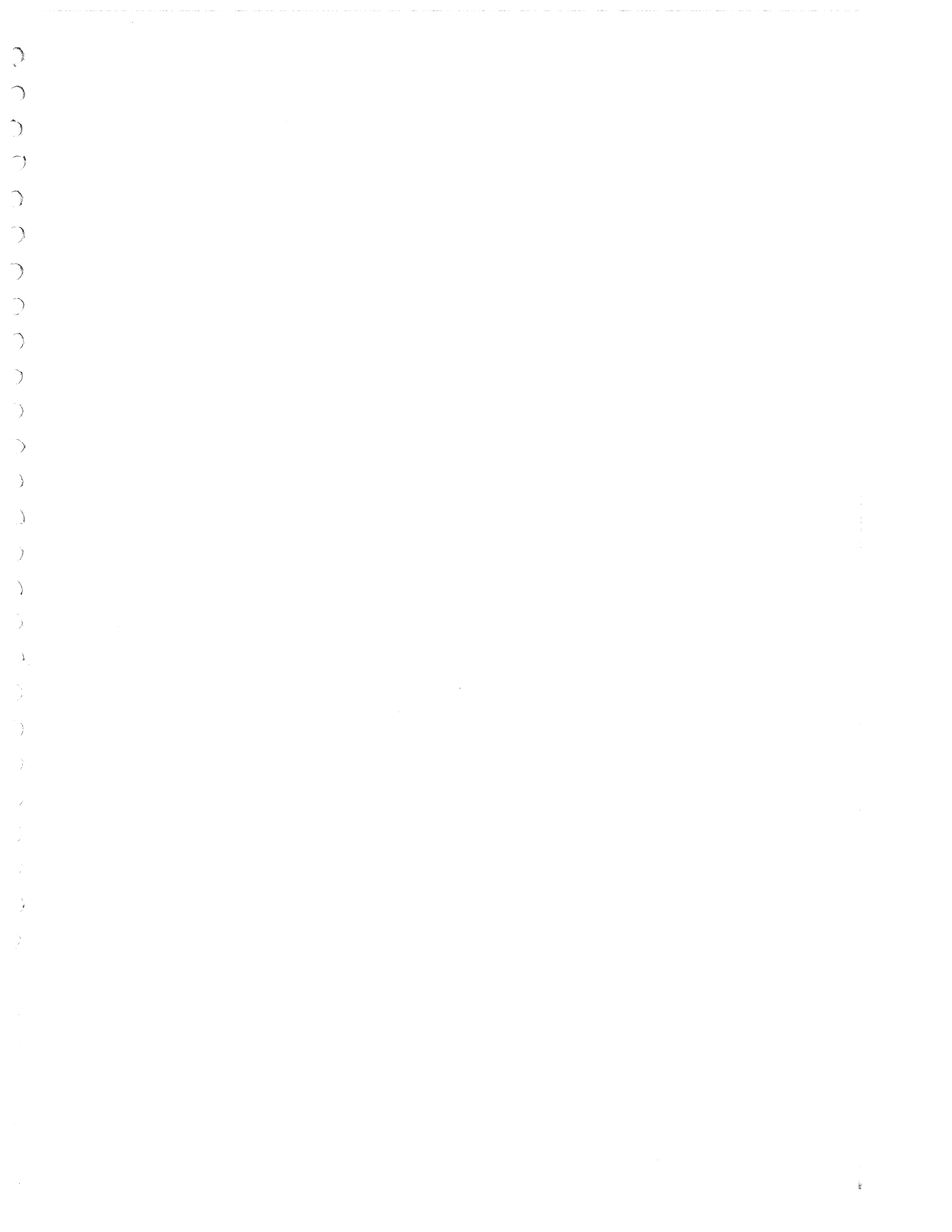



Time, Speed & Distance

Time term 'Time' and 'Distance' are related to the speed or velocity of a moving object.

SPEED:

We define the speed of an object as the distance travelled by it in per unit time interval. It is obtained by dividing the distance covered by the object, by the time it takes to cover that distance. Thus,

$$\text{Speed/velocity} = \frac{\text{Distance Travelled}}{\text{Time taken}}$$

Notes:

1. If the time taken is constant, the distance travelled is proportional to the speed, that is more the speed; more the distance travelled in the same time.
2. If the speed is constant, the distance travelled is proportional to the time taken that is more the distance travelled; more the time taken at the same speed.
3. If the distance travelled is constant, the speed is inversely proportional to the time taken, that is, more the speed; less the time taken for the same distance travelled.

1. $\text{Speed} = \frac{\text{Distance}}{\text{Time}}$

2. $\text{Distance} = \text{Speed} \times \text{Time}$

3. $\text{Time} = \frac{\text{Distance}}{\text{Speed}}$

Units of Measurement

Generally, if the distance is measured in kilometers, we measure time in hours and speed in kilometer per hour and is written as km/hr; and if distance is measured in metres then time is taken in second and speed in metre per second and is written as m/sec.

Conversion of Units

$$\text{km/hour} = \frac{1000 \text{ meter}}{60 \times 60 \text{ seconds}} = \frac{5}{18} \text{ m/sec.}$$

$$\therefore 1 \text{ m/sec} = \frac{18}{5} \text{ km/hr}$$

$$\text{Thus, } x \text{ km/hr} = \left(x \times \frac{5}{18} \right) \text{ m/sec.}$$

$$\text{and, } x \text{ m/sec} = \left(x \times \frac{18}{5} \right) \text{ km/hr}$$

Example 1: Raman can cover a distance of 30 km in 3 hours in his bicycle, calculate the speed of Raman.

Solution:

$$\text{Speed} = \frac{\text{Distance Covered}}{\text{Time taken}} = \frac{30}{3} = 10 \text{ km/hr}$$

Example 2: Sanjeev can cover a distance of 250 km by travelling at the speed of 50 km/hr. Find the time taken by him to cover the distance.

Solution:

$$\text{Time} = \frac{\text{Distance}}{\text{Speed}} = \frac{250}{50} = 5 \text{ hours}$$

Example 3: A train running at a speed of 90 km/hr passes a pole on the platform in 20 seconds. Find the length of the train in meters.

Solution:

$$\begin{aligned} \text{Speed of the train} &= 90 \text{ km/hr} \\ &= 90 \times \frac{5}{18} = 25 \text{ m/s} \end{aligned}$$

$$\begin{aligned} \therefore \text{Length of the train} &= \text{speed of the train} \times \\ &\text{time taken crossing the pole.} = 25 \times 20 \\ &= 500 \text{ m.} \end{aligned}$$

Relative Speed

CASE I: Same Direction

When objects are moving in same direction relative speed is equal to difference between speed of two objects.

Relative speed:

$$= S_1 - S_2 \quad \begin{array}{c} \xrightarrow{S_1} \\ \xrightarrow{S_2} \end{array}$$

Case -II: Opposite Direction

(face to face)/(back to back)

When objects are moving in opposite direction facing each other then

Relative speed = $(S_1 + S_2)$

$$\begin{array}{c} \xrightarrow{S_1} \quad \xleftarrow{S_2} \text{ (face to face)} \\ \xleftarrow{S_1} \quad \xrightarrow{S_2} \text{ (back to back)} \end{array}$$

Concept of Acceleration

Acceleration is defined as rate of change of speed.

Acceleration can be positive (speed increases) or negative (speed decreases); also known as deceleration

$$\text{Acceleration} = \frac{\text{Final Speed} - \text{Initial speed}}{\text{Time Duration}}$$

The unit of acceleration is m/s^2 .

For instance, if a body has an initial speed of 10 m/s^2 and speed increases to 20 m/s^2 within 4 seconds then

$$\text{Acceleration} = \frac{20 - 10}{4} = 2.5 \text{ m/s}^2$$

$$\text{Final speed} = \text{Initial speed} + \text{Acceleration} \times \text{Time}$$

Acceleration due to gravity

This is the acceleration induced by gravitational pull of earth $g = 9.8 \text{ m/s}^2$.

$$V = U + gt$$

Where:

U = initial speed

V = final speed

g = acceleration due to gravity and

t = time taken

$$S = Ut + \frac{1}{2}gt^2$$

where S = distance covered

Application of time speed & distance

A. Problems on Trains

Trains are a special case in questions related to time speed and distance because they have their own theory and situations.

The basic relation for trains problem is same speed \times Time = Distance

The following things need to be kept in mind before solving questions on trains

(a) when the train is crossing a moving object, the speed has to be taken as relative speed of the train with respect to the object. All the rules for relative speed will apply for calculating relative speed.

The distance to be covered when crossing an object, wherever a train crosses an object will be equal to :

Length of train + length of object

Thus, the following cases will yield separate equations, which will govern the crossing of the object by the train.

For each of the following situations the following notations have been used :

S_T = Speed of train

L_T = Length of train

S_o = Speed of object

L_o = Length of object

t = time taken

Case I: Train crossing a stationary object (pole, standing human being etc.) without length

$$t = \frac{L_T}{S_T}$$

Case II: Train crossing a stationary object with length : (eg → platform, Railway tunnel etc)

$$t = \frac{L_T + L_o}{S_T}$$

Case III: Train crossing a moving object without length.

→ In opposite direction:

$$t = \frac{L_T}{(S_T + S_o)}$$

→ In same direction:

$$t = \frac{L_T}{(S_T - S_o)}$$

Case IV: Train crossing a moving object with length:

In opposite direction.

$$t = \frac{L_T + L_o}{S_T + S_o}$$

→ In same direction

$$t = \frac{L_T + L_o}{S_T - S_o}$$

Example 1: A train crosses a pole in 15 seconds. If the length of the train is 300 metres, find the speed of the train.

Solution: $t = \frac{L_T}{S_T}$

So $\frac{L_T}{t} = \frac{300}{15} = 20 \text{ m/sec.}$

Example 2: Two trains of length 120 metres and 80 metres are running on parallel lines in opposite directions with the speed of 35 km/hr and 55 km/hr respectively. In what time will they pass each other.

Solutions: $t = \frac{L_T + L_o}{S_T + S_o}$

here $S_T + S_o = 35 + 55 = 90 \text{ km/hr}$

$= 90 \times \frac{5}{18} = 25 \text{ m/sec}$

$= 90 \times \frac{5}{18} = 25 \text{ m/s}$

So, $t = \frac{120 + 80}{25} = \frac{200}{25} = 8 \text{ seconds.}$

□□□□

Boats and Streams

The problems of boats and streams are also dependent on the basic equation of time, speed and distance.

Speed \times Time = Distance.

The speed of Boat is let S_B

The speed of stream is S_S

The speed of movement of boat is dependent on whether the boat is moving in which directions

(a) In still water $S_S = 0$

Speed of Boat = S_B

(b) While moving upstream (or against the flow of the water), the speed of movement is given by $S_U = S_B - S_S$

(c) While moving down stream (or with the flow of the water), the speed of movement is given by

$S_D = S_B + S_S$

□□□□



Solved Examples

1. Walking at $\frac{3}{4}$ of his normal speed, Ankur is 16 minutes late in reaching his office. The usual time taken by him to cover the distance between his home and his office is

- (a) 48 minutes (b) 60 minutes
(c) 42 minutes (d) 62 minutes

Ans. (a)

Speed \times Time = Distance

$S \times T = D$

here S is changed to $\frac{3}{4}S$ so T must be

changed to $\frac{4}{3}T$ to keep D constant i.e.

$$\frac{3}{4}S \times \frac{4}{3}T = D$$

$$\text{Now } \frac{3}{4}T = T + 16$$

$$\text{So } \frac{1}{3}T = 16; T = 48$$

2. Sanjay and Naveen travel the same distance at the rate of 6 km per hour and 10 km per hour respectively. If Sanjay takes 30 minutes longer than Naveen, the distance travelled by each is

- (a) 6 km (b) 10 km
(c) 7.5 km (d) 20 km

Ans. (c)

$$\frac{D}{S_1} - \frac{D}{S_2} = \frac{1}{2} \text{ hour}$$

$$\frac{D}{6} - \frac{D}{10} = \frac{1}{2} \Rightarrow D \left[\frac{1}{6} - \frac{1}{10} \right] = \frac{1}{2}$$

$$D = \frac{15}{2} = 7.5 \text{ km}$$

3. Two trains, Calcutta Mail and Bombay Mail, start at the same time from stations Calcutta and Bombay respectively towards each other. After passing each other, they take 12 hours and 3 hours to reach Bombay and Calcutta respectively. If the Calcutta Mail is moving at the speed of 48 km/h, the speed of the Bombay Mail is

- (a) 24 km/h (b) 22 km/h
(c) 21 km/h (d) 96 km/h

Ans. (d)

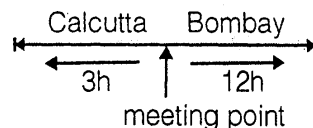

$$\text{in this case } \frac{S_1}{S_2} = \frac{\sqrt{T_2}}{\sqrt{T_1}}$$

$$= \frac{48}{S_2} = \frac{\sqrt{3}}{\sqrt{12}} = \frac{1}{2} \quad S_2 = 96 \text{ km/h}$$

4. Walking at $\frac{3}{4}$ of his normal speed, a man takes $2\frac{1}{2}$ hours more than the normal time. Find the normal time.

- (a) 7.5 h (b) 6 h
(c) 8 h (d) 12 h

Ans. (a)

$$S \times T = D \text{ (constant)}$$

$$\frac{3}{4}S \times \frac{4}{3}T = D$$

$$\text{Now } \frac{4}{3}T = T + \frac{5}{2}$$

$$T = \frac{15}{2} = 7.5 \text{ h}$$

5. What is the time taken by Rohan to cover a distance of 360 km by a motorcycle moving at a speed of 10 m/s

- (a) 10 h (b) 5 h
(c) 8 h (d) 6 h

Ans. (a)

$$10 \text{ m/s} = 10 \times \frac{18}{5} = 36 \text{ km/h}$$

$$\text{Time} = \frac{\text{Distance}}{\text{Speed}} = \frac{360}{36} = 10 \text{ h}$$

6. Rajdhani Express travels 650 km in 5 h and another 940 km in 10 h. What is the average speed of train?

- (a) 1590 km/h (b) 63 km/h
(c) 106 km/h (d) 126 km/h

Ans. (c)

$$\text{Average speed} = \frac{\text{Total Distance Travelled}}{\text{Total Time taken}}$$

$$= \frac{650 + 940}{15} = 106 \text{ km/h}$$

7. A car travels from A to B at V_1 km/h, travels back from B to A at V_2 km/h and again goes back from A to B at V_2 km/h. The average speed of the car is :

(a) $\frac{2V_1V_2}{V_1 + 2V_2}$ (b) $\frac{2V_1V_2}{V_2 + 2V_1}$

(c) $\frac{3V_1V_2}{V_2 + 2V_1}$ (d) $\frac{3V_1V_2}{V_1 + 2V_2}$

Ans. (c)

$$\text{Average speed} = \frac{\text{Total Distance}}{\text{Total Time}}$$

$$= \frac{3D}{\frac{D}{V_1} + \frac{D}{V_2} + \frac{D}{V_2}} = \frac{3}{\frac{1}{V_1} + \frac{2}{V_2}} = \frac{3V_1V_2}{2V_1 + V_2}$$

8. Narayan Murthy walking at a speed of 20 km/h reaches his college 10 minutes late. Next time he increases his speed by 5 km/h. but finds that he is still late by 4 minutes. What is the distance of his college from his house.

- (a) 20 km (b) 6 km
(c) 12 km (d) None of these

Ans. (d)

Let distance be D km

$$\frac{D}{20} = T + \frac{10}{60} \quad (1)$$

also $\frac{D}{25} = T + \frac{4}{60} \quad (2)$

from (1) and (2) we get

$$D \times \frac{1}{100} = \frac{1}{10}$$

$$D = \frac{100}{10} = 10 \text{ km}$$

9. Jayshree goes to office at a speed of 6 km/h and returns to her home at a speed of 4 km/h. If she takes 10 hours in all, what is the distance between her office and her home?

- (a) 24 km (b) 12 km
(c) 10 km (d) None of these

Ans. (a)

Let the distance be D km then

$$\frac{D}{6} + \frac{D}{4} = 10 \quad D \left[\frac{1}{6} + \frac{1}{4} \right] = 10$$

$$D = \frac{10}{\left(\frac{5}{12}\right)} = 24 \text{ km}$$

10. A motor car does a journey in 17.5 hours, covering the first half at 30 km/h and the second half at 40 km/h. Find the distance of the journey.

- (a) 684 km (b) 600 km
(c) 120 km (d) 540 km

Ans. (b)

Here Total time = 17.5 hours
let total Distance be 2D km

$$\text{then } \frac{D}{30} + \frac{D}{40} = 17.5$$

$$D \left[\frac{1}{30} + \frac{1}{40} \right] = 17.5$$

$$D \times \frac{7}{120} = 17.5$$

$$D = \frac{17.5 \times 120}{7}$$

$$D = 300 \text{ km}$$

$$\text{Total Distance} = 2D = 600 \text{ km}$$

11. Manish travels a certain distance by car at the rate of 12km/h and walks back at the rate of 3 km/h. The whole journey took 5 hours. What is the distance he covered on the car?

- (a) 12 km (b) 30km
(c) 15 km (d) 6 km

Ans. (a)

Let Distance be D km

$$\frac{D}{12} + \frac{D}{3} = 5 \quad D \left(\frac{1}{12} + \frac{1}{3} \right) = 5$$

$$D = \frac{5 \times 12}{5} = 12 \text{ km}$$

12. A railway passenger counts the telegraph poles on the rail road as he passes them. The telegraph poles are at a distance of 50 meters. What will be his count in 4 hours, if the speed of the train is 45 km per hour.

- (a) 600 (b) 2500
(c) 3600 (d) 5000

Ans. (c)

$$\text{Total Distance covered} = 45 \times 4 = 180 \text{ km}$$

$$\text{Number of Poles} = \frac{180000}{50} = 3600$$

13. Two trains A and B start simultaneously in the opposite direction from two points A and B and arrive at their destinations 9 and 4 hours respectively after their meeting each other. At what rate does the second train B travel if the first train travels at 80 km per hour.

- (a) 60 km/h (b) 100 km/h
(c) 120 km/h (d) None of these

Ans. (c)

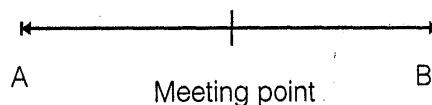

$$\frac{S_1}{S_2} = \frac{\sqrt{T_2}}{\sqrt{T_1}}$$

$$S_2 = \frac{\sqrt{4}}{\sqrt{9}} \quad \frac{80}{S_2} = \frac{2}{3}$$

$$S_2 = 120 \text{ km/hour}$$

14. A journey of 192 km takes 2 hours less by a fast train than by a slow train. If the average speed of the slow train be 16 kmph less than that of fast train, what is the average speed of the faster train.

- (a) 32 kmph (b) 16 kmph
(c) 12 kmph (d) 48 kmph

Ans. (d)

let speed of fast train be S km/hour then

$$\frac{192}{S-16} - \frac{192}{S} = 2 \quad (1)$$

This type of questions can be directly solved by going through option

heare using equation (1) and puting options we get $S = 48$ km/hour

15. A passenger train takes 2 h less for a journey of 300 kilometres if its speed is increased by 5 kmph over its usual speed. Find the usual speed.

- (a) 10 kmph (b) 12 kmph
(c) 20 kmph (d) 25 kmph

Ans. (d)

$$\frac{300}{S} - \frac{300}{S+5} = 2 \quad (1)$$

going directly through options and using equation (1) we get

$S = 25$ km/hour

16. A plane left half an hour later than the scheduled time and in order to reach its destination 1500 kilometre away in time, it had to increase its speed by 33.33 per cent over its usual speed. Find its increased speed.

- (a) 250 kmph (b) 500 kmph
(c) 750 kmph (d) None of these

Ans. (c)

$33.33\% = \frac{1}{3}$ of normal speed

$$\frac{D}{S + \frac{1}{3}S} - \frac{D}{S} = \frac{1}{2}$$

$$\frac{1500}{4/3S} - \frac{1500}{S} = \frac{1}{2} \quad (1)$$

going through option and (1) we get

$S = 750$ km/hour

17. A train moves at a constant speed of 120 km/h for one kilometre and at 40 kmph for the next one kilometre. What is the average speed of the train.

- (a) 48 kmph (b) 50 kmph
(c) 80 kmph (d) None of these

Ans. (d)

$$\text{Average Speed} = \frac{\text{Distance covered}}{\text{Time taken}}$$

$$= \frac{1+1}{\frac{1}{120} + \frac{1}{40}} = \frac{2 \times 120 \times 40}{120 + 40}$$

$$= 60 \text{ km/hour}$$

18. A car travels $\frac{1}{3}$ of the distance on a straight road with a velocity of 10 km/h, the next $\frac{1}{3}$ with a velocity of 20 km/h and the last $\frac{1}{3}$ with a velocity of 60 km/h. What is the average velocity of the car for the whole journey?

- (a) 18 km/h (b) 10 km/h
(c) 20 km/h (d) 15 km/h

Ans. (a)

$$\text{Average speed} = \frac{\text{Distance Covered}}{\text{Time taken}}$$

$$= \frac{\frac{D}{3} + \frac{D}{3} + \frac{D}{3}}{\frac{D}{3} \times \frac{1}{20} + \frac{D}{3} \times \frac{1}{10} + \frac{D}{3} \times \frac{1}{60}} = \frac{3}{\frac{1}{20} + \frac{1}{10} + \frac{1}{60}}$$

$$= 18 \text{ km/hour}$$

19. Walking at $\frac{3}{4}$ of his usual speed, a man is 16 minutes late for his office. The usual time taken by him to cover that distance is

- (a) 48 minutes (b) 60 minutes
(c) 42 minutes (d) 62 minutes

Ans. (a)

$$S \times T = \text{Distance (constant)}$$

$$\frac{3}{4}S \times \frac{4}{3}T = D$$

$$\text{Time has become } \frac{4}{3}T,$$

$$\text{Now } \frac{4}{3} T - T = 16 \text{ minutes}$$

$$T = 48 \text{ minutes}$$

20. Two trains for Patna leave Delhi at 6 a.m. and 6.45 a.m. and travel at 98 kmph and 136 kmph respectively. How many kilometres from Delhi will the two trains meet?

- (a) 262.4 km (b) 260 km
(c) 200 km (d) None of these

Ans.(d)



Distance travelled by 1st train in 45 minutes

$$= 98 \times \frac{45}{60} = 73.5 \text{ km} = \frac{147}{2} \text{ km}$$

Relative speed = $S_2 - S_1 = 136 - 98 = 38 \text{ km/hr}$

Time taken to cover 73.5 km is

$$\frac{73.5}{38} = \frac{147}{2} \times \frac{1}{38} = \frac{147}{76} \text{ hour}$$

$$\text{Distance} = \frac{147}{76} \times 98 = 189.55$$

Total distance = $73.5 + 189.55 = 263 \text{ km approx}$

21. X and Y are two stations 600 km apart. A train starts from X and moves towards y at the rate of 25 km/h. Another train starts from y at the 35 km/h. How far from x they will cross each other

- (a) 250 km (b) 300 km
(c) 450 km (d) 475 km

Ans. (a)

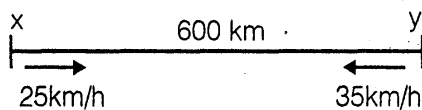

Time taken to meet each other

$$= \frac{600}{35 + 25} = 10 \text{ h.}$$

Distance from x = $10 \times 25 = 250 \text{ km}$

22. A motorboat went downstream for 28 km and immediately returned. It took the boat twice as long to make the return trip. If the speed of the river flow were twice as high, the trip downstream and back would take 672 minutes. Find the speed of the boat in still water and the speed of the river flow.

- (a) 9 km/h, 3 km/h (b) 9km/h, 6km/h
(c) 8km/h, 2 km/h (d) 12 km/h, 3 km/h

Ans.(a)

Let speed of boat be S_B

Speed of stream = S_S

$$\text{then } \frac{28}{S_B - S_S} = 2 \times \frac{28}{S_B + S_S}$$

$$\text{also } \frac{28}{S_B + S_S} + \frac{28}{S_B - S_S} = 672 \text{ minutes}$$

going directly by option

$$S_B = 9 \text{ km} \quad S_S = 3 \text{ km}$$

23. A train requires 7 seconds to pass a pole while it requires 25 seconds to cross a stationary train which is 378 metres long. Find the speed of the train.

- (a) 75.6 km/h (b) 75.4 km/h
(c) 76.2 km/h (d) 21 km/h

Ans. (a)

To cross a pole

$$t = \frac{L_T}{S_T} = \frac{\text{length of train}}{\text{speed of train}}$$

$$7 = \frac{L_T}{S_T} \quad (1)$$

$$\text{also to cross a stationary train } t = \frac{L_T + L_S}{S_T}$$

L_S = length of stationary train

$$25 = \frac{L_T + 378}{S_T} \quad (2)$$

from (1) and (2)

$$7 \times S_T = L_T$$

$$25 \times S_T = L_T + 378$$

$$18 S_T = 378$$

$$S_T = 21 \text{ m/s} = 21 \times \frac{18}{5} = 75.6 \text{ km/h}$$

24. A boat sails down the river for 10 km and then up the river for 6 km. The speed of the river flow is 1 km/h. What should be the minimum speed of the boat for the trip to take a maximum of 4 hours?

- (a) 2 kmph (b) 3 kmph
(c) 4 kmph (d) 5 kmph

Ans. (c)

$$\frac{D_1}{S_B + S_S} + \frac{D_2}{S_B - S_S} = 4 \text{ hour}$$

$$\frac{10}{S_B + 1} + \frac{6}{S_B - 1} = 4 \text{ hour} \quad (1)$$

going by option and (1) we get

$$S_B = 4 \text{ km/hour}$$

25. Two trains are running on parallel lines in the same direction at speeds of 40 kmph and 20 kmph respectively. The faster train crosses a man in the second train in 36 seconds. The length of the faster train is

- (a) 200 metres (b) 185 metres
(c) 225 metres (d) 210 metres

Ans. (a)

t = time required

$$\frac{L_T + L_o}{S_T - S_o} \quad (1)$$

$$S_T - S_o = 40 - 20 = 20 \text{ km/h}$$

$$= 20 \times \frac{5}{18} = \frac{50}{9} \text{ m/s}$$

$$\text{now } t = \frac{L_T}{\frac{50}{9}} \Rightarrow 36 = \frac{L_T}{9}$$

$$\text{So, } L_T = 200 \text{ m}$$

26. The speed of the boat in still water is 12 km/h and the speed of the stream is 2 km/h. A distance of 8 km, going upstream, is covered in

- (a) 1 h (b) 1h15 min
(c) 1 h 12 min (d) None of these

Ans. (d)

$$t = \frac{D}{S_B - S_S} \text{ (upstream)}$$

$$= \frac{8}{12 - 2} = \frac{8}{10} = \frac{8}{10} \times 60 = 48 \text{ min}$$

27. A boat goes 15 km upstream in 80 minutes. The speed of the stream is 5 km/h. The speed of the boat in still water is

- (a) 16.25 km/h (b) 16 km/h
(c) 15 km/h (d) 17 km/h

Ans. (a)

$$t = \frac{D}{S_B - S_S} \text{ (upstream)}$$

$$\frac{80}{60} = \frac{15}{S_B - 5} \Rightarrow \frac{4}{3} = \frac{15}{S_B - 5}$$

$$S_B = 16.25 \text{ km/h}$$

28. In a stream, B lies in between A and C such that it is equidistant from both A and C. A boat can go from A to B and back in 6 h 30 minutes while it goes from A to C in 9 h. How long would it take to go from C to A?

- (a) 3.75 h (b) 4 h
(c) 4.25 h (d) 4.5 h

Ans. (b)

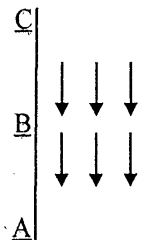

let $AB = D$ km then

$BC = D$ km

$AC = 2D$ km

$$\frac{D}{S_B - S_S} + \frac{D}{S_B + S_S} = \frac{13}{2} \quad (1)$$

$$\frac{2D}{S_B - S_S} = 9 \quad (2)$$

$$\text{So } \frac{D}{S_B - S_S} = \frac{9}{2} \quad (3)$$

from (1) and (3) we get

$$\frac{9}{2} + \frac{D}{S_B + S_S} = \frac{13}{2}$$

$$\frac{D}{S_B + S_S} = 2$$

to go from C to A it takes

$$\frac{2D}{S_B + S_S} = 4 \text{ hours}$$

29. Two trains are travelling in the same direction at 50 km/h and 30 km/h respectively. The faster train crosses a man in the slower train in 18 seconds. Find the length of the faster train.

- (a) 0.1 km (b) 1 km
(c) 1.5 km (d) 1.4 km

Ans. (a)

$$t = \frac{L_T + L_o}{S_T - S_o}$$

$$50 - 30 = 20 \text{ km/hr} = 50/9 \text{ m/s}$$

$$\text{now } 18 = \frac{L_T}{50/9} \Rightarrow L_T = 100 \text{ m}$$

30. Without stoppage, a train travels at an average speed of 75 km/h and with stoppages it covers the same distance at an average speed of 60 km/h. How many minutes per hour does the train stop?

- (a) 10 minutes (b) 12 minutes
(c) 14 minutes (d) 18 minutes

Ans. (b)

Speed of trains are 75 km/h and 60 km/h. and to cover a distance of 60 km train will take 60 minutes in second case (with stoppage) while without stoppage it will take

$$\frac{60}{75} = 48 \text{ minutes}$$

So, stoppage = 12 minutes

31. A boat rows 16 km up the stream and 30 km down stream taking 5 h each time. The velocity of the current

- (a) 1.1 km/h (b) 1.2 km/h
(c) 1.4 km/h (d) 1.5 km/h

Ans. (c)

$$\frac{16}{S_B - S_S} = 5 \text{ hour}$$

$$\frac{30}{S_B + S_S} = 5 \text{ hour}$$

$$16 = 5S_B - 5S_S \quad (1)$$

$$30 = 5S_B + 5S_S \quad (2)$$

$$14 = 10S_S$$

$$S_S = 1.4 \text{ km/hr}$$

32. A lazy man can row upstream at 16 km/h and downstream at 22 km/h. Find the man's rate in still water (in kmph.).

- (a) 19 (b) 14
(c) 17 (d) 18

Ans. (a)

Man's rate in still water

$$\text{here } S_B - S_S = 16$$

$$S_B + S_S = 22 \text{ km}$$

$$\text{So, } S_B = \frac{16+22}{2} = 19 \text{ km/hr}$$

33. A man can row 30 km upstream and 44 km downstream in 10 hours. It is also known that he can row 40 km upstream and 55 km downstream in 13 hours. Find the speed of the man in still water:

- (a) 4 km/h (b) 6 km/h
 (c) 8 km/h (d) 12 km/h

Ans. (c)

$$\frac{30}{S_B - S_S} + \frac{44}{S_B + S_S} = 10 \text{ also}$$

$$\frac{40}{S_B - S_S} + \frac{55}{S_B + S_S} = 13$$

let $\frac{1}{S_B - S_T} = x$ and $\frac{1}{S_B + S_S} = y,$

then

$$30x + 44y = 10 \quad (1)$$

$$40x + 165 = 13 \quad (2)$$

By solving we get
 $S_B = 8$ km/hr.

34. In a stream that is running at 2 km/h, a man goes 10 km upstream and comes back to the starting point in 55 minutes. Find the speed of the man in still water.
 (a) 20 km/h (b) 22 km/h
 (c) 24 km/h (d) 28 km/h

Ans.(b)

$$\frac{10}{S_B - 2} + \frac{10}{S_B + 2} = \frac{55}{60} = \frac{11}{12} \quad (i)$$

on solving eg (i) we get
 $S_B = 22$ km/hr

35. A man goes down stream at x km/h and upstream at y km/h. The speed of the boat in still water is
 (a) $0.5(x + y)$ (b) $0.5(x - y)$
 (c) $x + y$ (d) $x - y$

Ans. (a)

Speed of Boat

$$= \left(\frac{\text{Upstream} + \text{Downstream}}{2} \right)$$

$$= \frac{x+y}{2} = 0.5(x + y)$$

36. A motorboat went down the river for 14 km and then up the river for 9 km. It took a total

of 5 hours for the entire journey. Find the speed of the river flow if the speed of the boat in still water is 5 km/h.

- (a) 1 kmph (b) 1.5 kmph
 (c) 2 kmph (d) 3 kmph

Ans.(c)

$$\frac{14}{S_B + S_S} + \frac{9}{S_B - S_S} = 5$$

$$\frac{14}{5 + S_S} + \frac{9}{5 - S_S} = 5$$

using equation and going by option we get
 $S_S = 2$ km/hr

37. A motorboat whose speed in still water is 10 km/h went 91 km downstream and then returned to its starting point. Calculate the speed of the river flow if the round trip took of 20 hours.
 (a) 3 km/h (b) 4 km/h
 (c) 2 km/h (d) 8 km/h

Ans.(a)

$$\frac{91}{S_B + S_S} + \frac{91}{S_B - S_S} = 20$$

$$\frac{91}{10 + S_S} + \frac{91}{10 - S_S} = 20$$

$$S_S = 3 \text{ km/hr.}$$

38. A motorboat whose speed in still water is 15 kmph goes 30 km downstream and comes back in a total 4 hours 30 min. Determine the speed of the stream.
 (a) 2 kmph (b) 3 kmph
 (c) 4 kmph (d) 5 kmph

Ans.(d)

$$S_B = 15 \text{ km/h}$$

$$D = 30 \text{ km}$$

$$t = \frac{9}{2} \text{ hr} = \frac{30}{15 + S_S} + \frac{30}{15 - S_S} = \frac{9}{2}$$

$$S_S = 5 \text{ kmph}$$



Time, Speed & Distance



Practice Exercise: I

- Ramesh crosses a street 600 m long in 5 minutes. His speed in km/hr is
(a) 8.2 (b) 7.2
(c) 9.2 (d) None of these
- A train 100 metres long passes a bridge at the rate of 72 km/hr in 25 seconds. What is the length of the bridge?
(a) 400 m (b) 17 m
(c) 600 m (d) None of these
- A train passes a railway bridge 150 m long in 18 seconds. If the train is running at a speed of 60 km/hr., then the length of the train in metres is
(a) 160 m (b) 150 m
(c) 180 m (d) None of these
- Sound travels 330 metres a second. If the sound of a thunder-cloud follows the flash after 10 seconds. The thunder-could is at a distance of
(a) 3.7 km (b) 3.5 km
(c) 3.3 km (d) None of these
- The wheel of an engine is $3\frac{3}{4}$ metres in circumference and makes 4 revolutions in 2 seconds. The speed of the train is
(a) 27 km/hr (b) 31 km/hr
(c) 35 km/hr (d) None of these
- A person covers half of his journey at 30 km/hr and the remaining half 20 km/hr. The average speed for the whole journey is
(a) 25 km/hr (b) 28 km/hr
(c) 32 km/hr (d) None of these
- A and B are two towns. A car goes from A to B at a speed of 64 km/hr and returns to A at a slower speed. If its average speed for the whole journey is 56 km/hr, it returned with speed
(a) 52.54 km/hr (b) 47.74 km/hr
(c) 49.78 km/hr (d) None of these
- On a tour a man travels at the rate of 64 km an hour for the first 160 km, then travels the next 160km at the rate of 80 km an hour. The average speed in km per hour for the first 320 km of the tour is
(a) 81.13 km/hr (b) 73.11 km/hr
(c) 71.11 km/hr (d) None of these
- Rakesh sets out to cycle from Delhi to Mathura and at the same time Suresh starts from Mathura to Delhi. After passing each other they complete their journeys in 9 and 16 hours, respectively. At what speed does Suresh cycle if Rakesh cycles at 16 km per hour?
(a) 12 km/hr (b) 16 km/hr
(c) 14 km/hr (d) None of these
- A car during its journey travels 30 minutes at a speed of 40km/hr, another 45 minutes at a speed of 60 km/hr, and 2 hours at a speed of 70 km/hr. The average speed of the car is
(a) 68 km/hr (b) 65 km/hr
(c) 70 km/hr (d) None of these
- By walking at $\frac{3}{4}$ of his usual speed, a man reaches office 20 minutes later than usual. His usual time is
(a) 65 minutes (b) 60 minutes
(c) 70 minutes (d) None of these
- A car start from A for B travelling 20 km an hour. $1\frac{1}{2}$ hours later another car starts from A and travelling at the rate of 30 km an hour reaches B $2\frac{1}{2}$ hours before the first car. Find the distance from A to B

- (a) 280 km (b) 260 km
(c) 240 km (d) None of these
13. A train does a journey without stopping in 8 hours. If it had travelled 5 km an hour faster, it would have done the journey in 6 hours 40 min. What is its slower speed?
(a) 35 km/hr (b) 25 km/hr
(c) 40 km/hr (d) None of these
14. Without any stoppage a person travels a certain distance at an average speed of 42 km/hr and with stoppages he covers the same distance at an average speed of 28 km/hr. How many minutes per hour does he stop?
(a) 25 minutes (b) 30 minutes
(c) 20 minutes (d) None of these
15. A train passes through a telegraph post in 9 seconds moving with a speed of 54 km per hour. The length of the train is
(a) 135 metres (b) 145 metres
(c) 125 metres (d) None of these
16. A train 50 m long passes a platform 100 m long in 10 seconds. The speed of the train in m/sec. is
(a) 25 (b) 15
(c) 35 (d) None of these
17. A train 300 metres long is running at a speed of 90 km/hr. How many seconds will it take to cross a 200 metres long train running in the same direction at a speed of 60 km/hr?
(a) 70 sec. (b) 60 sec.
(c) 50 sec. (d) None of these
18. Two trains are running in opposite directions with the same speed. If the length of each train is 135 metres and they cross each other in 18 seconds, the speed of each train is
(a) 29 km/hr (b) 35 km/hr
(c) 27 km/hr (d) None of these
19. Two trains are moving in the same direction at 50 km/hr and 30 km/hr. The faster train crosses a man in the slower train in 18 seconds. Find the length of the faster train.
(a) 120 m (b) 110 m
(c) 100 m (d) None of these
20. Two trains, 130 m and 110 m long, while going in the same direction, the faster train takes one minute to pass the other completely. If they are moving in opposite direction, they pass each other completely in 3 seconds. Find the speed of each train.
(a) 42 m/sec., 38 m/sec.
(b) 38 m/sec., 36 m/sec.
(c) 36 m/sec., 42 m/sec.
(d) None of these
21. Two stations A and B are 100 km apart on a straight line. One train starts from A at 7 A.M. and travels towards B at 20 km/hr speed. Another train starts from B at 8 A.M. and travels towards A at 25 km/hr. speed. At what time will they meet?
(a) 10.30 A.M. (b) 11 A.M.
(c) 10 A.M. (d) None of these
22. Two trains start at the same time from Mumbai and Pune and proceed towards each other at the rate of 60 km and 40 km per hour, respectively. When they meet, it is found that one train has travelled 20 km more than the other. Find the distance between Mumbai and Pune.
(a) 150 km (b) 100 km
(c) 120 km (d) None of these
23. A boy takes as much time in running 12 metres as a car takes in covering 36 metres. The ratio of the speeds of the boy and the car is
(a) 1 : 3 (b) 1 : 2
(c) 2 : 3 (d) 2 : 5

24. A and B are two stations. A train goes from A to B at 64 km/hr and returns to A at a slower speed. If its average speed for the whole journey is 56 km/hr, at what speed did it return?
 (a) 48 km/hr (b) 49.77 km/hr
 (c) 30 km/hr (d) 47.46 km/hr
25. Excluding stoppages, the speed of a bus is 54 km/hr and including stoppages, it is 45 km/hr. For how many minutes does the bus stop per hour?
 (a) 9 (b) 10
 (c) 12 (d) 20
26. Ramesh sees a train passing over 1 km long bridge. The length of the train is half that of bridge. If the train clears the bridge in 2 minutes, the speed of the train is
 (a) 45 km/hr (b) 43 km/hr
 (c) 50 km/hr (d) None of these
27. Amit started cycling along the boundaries of a square field from cover point A. After half an hour, he reached the corner point C, diagonally opposite to A. If his speed was 8 km/hr, what is the area of the field in square km
 (a) 64
 (b) 8
 (c) 4
 (d) Cannot be determined
28. A motor cyclist goes from Mumbai to Pune, a distance of 192 kms, at an average speed of 32 km p.h. Another man starts from Mumbai by car, $2\frac{1}{2}$ hours after the first and reaches Pune half an hour earlier. What is the ratio of the speed of the motorcycle and the car?
 (a) 1 : 2 (b) 1 : 3
 (c) 10 : 27 (d) 5 : 4
29. A person sets to cover a distance of 12 km in 45 minutes. If he covers $\frac{3}{4}$ of the distance in $\frac{2}{3}$ rd time, what should be his speed to cover the remaining distance in the remaining time?
 (a) 16 km/hr (b) 8 km/hr
 (c) 12 km/hr (d) 14 km/hr
30. A train 110 metres in length passes a man walking at the speed of 6 km/hr. against it in 6 seconds. The speed of the train in km per hour is
 (a) 60 km/hr (b) 45 km/hr
 (c) 50 km/hr (d) 55 km/hr

Solutions

1. Ans. (b)

$$\begin{aligned} \text{Speed} &= \frac{\text{Distance travelled}}{\text{Time taken}} \\ &= \left(\frac{600}{5 \times 60} \right) \text{m/sec} \\ &= \left(\frac{600}{5 \times 60} \times \frac{18}{5} \right) \text{km/hr} = 7.2 \text{ km/hr.} \end{aligned}$$

2. Ans. (a)

Distance travelled by the train in 25 seconds at 72 km/hr.

$$= 72 \times \frac{5}{18} \times 25 = 500 \text{ m}$$

$$\begin{aligned} \therefore \text{Length of the Bridge} &= 500 - \text{length of train} \\ &= 500 - 100 = 400 \text{ m.} \end{aligned}$$

3. Ans. (b)

Let the length of the train be x m.

$$\begin{aligned} \therefore \text{Total distance covered by the train} \\ &= (x + 150) \text{m} \end{aligned}$$

Speed of the train = 60 km/hr

$$= 60 \times \frac{5}{18} = \frac{50}{3} \text{ m/sec}$$

Since, Distance = Speed \times time

$$\therefore x + 150 = \frac{50}{3} \times 18 = 300$$

or, $x = 300 - 150 = 150 \text{ m}$.

\therefore Length of the train = 150 m.

4. Ans. (c)

Distance of thunder-cloud

= distance travelled by sound in 10seconds

= (330 \times 10) metres

= 3.3 km.

5. Ans. (a)

Distance covered in 2 seconds

$$= \frac{15}{4} \times 4 = 15 \text{ m.}$$

$$\therefore \text{Speed} = \frac{\text{Distance}}{\text{Time}} = \frac{15}{2} \text{ m/sec}$$

$$= \left(\frac{15}{2} \times \frac{18}{5} \right) \text{ km/hr} = 27 \text{ km/hr.}$$

6. Ans. (a)

Here, $S_1 = 30$ and $S_2 = 20$

$$\therefore \text{Average speed} = \left(\frac{2s_1s_2}{s_1 + s_2} \right)$$

$$= \frac{2 \times 30 \times 20}{30 + 20} = 25 \text{ km/hr.}$$

7. Ans. (c)

Let the speed on the return journey be x km/hr.

$$\text{Then, } 56 = \left(\frac{2s_1s_2}{s_1 + s_2} \right) = \frac{2 \times 64 \times x}{64 + x}$$

$$\therefore 7(64 + x) = 16x \text{ or } 9x = 448$$

$$\therefore x = \frac{448}{9} = 49.78 \text{ km/hr.}$$

8. Ans. (c)

Here, $S_1 = 64$ and $S_2 = 80$.

\therefore Average speed

$$= \left(\frac{2s_1s_2}{s_1 + s_2} \right) = \frac{2 \times 64 \times 80}{64 + 80}$$

$$= 71.11 \text{ km/hr.}$$

9. Ans. (a)

$$\frac{\text{Rakesh's speed}}{\text{Suresh's speed}} = \frac{\sqrt{T_2}}{\sqrt{T_1}} = \frac{\sqrt{16}}{\sqrt{9}} = \frac{4}{3}$$

$$\therefore \text{Suresh's speed} = \frac{3}{4} \text{ Rakesh's speed}$$

$$= \frac{3}{4} \times 16 = 12 \text{ km/hr}$$

10. Ans. (a)

$$\text{Here, } T_1 = \frac{30}{60}, T_2 = \frac{45}{60}, T_3 = 2, s_1 = 40$$

$s_2 = 60$ and $s_3 = 70$.

\therefore The average speed of the car

$$= \frac{s_1T_1 + s_2T_2 + s_3T_3}{T_1 + T_2 + T_3}$$

$$= \frac{40 \times \frac{30}{60} + 60 \times \frac{45}{60} + 70 \times 2}{\frac{30}{60} + \frac{45}{60} + 2}$$

$$= 63 \text{ km/hr.}$$

11. Ans. (b)

Here, change in time = 20 and $\frac{a}{b} = \frac{3}{4}$

We have, change in time

$$= \left(\frac{b}{a} - 1 \right) \times \text{original time}$$

$$\Rightarrow \text{Original time} = \frac{\text{Change in time}}{\left(\frac{b}{a} - 1 \right)}$$

$$= \frac{20}{\left(\frac{4}{3}-1\right)} = 60 \text{ minutes}$$

12. Ans. (c)

Here, difference in speed = $30 - 20 = 10$.

$$\text{difference in time} = 2\frac{1}{2} + 1\frac{1}{2} = 4$$

and product of speed = $20 \times 30 = 600$.

We have,

$$\frac{\text{Product of speed}}{d} = \frac{\text{difference of speed}}{\text{difference of time}}$$

$$\Rightarrow d = \text{product of speed} \times \left(\frac{\text{Diff. of time}}{\text{Diff. of speed}} \right)$$

$$600 \times \frac{4}{10} = 240 \text{ km}$$

13. Ans. (b)

Let the slower speed = s km/hr.

Since the distance travelled is same in both the cases therefore,

$$\frac{s_1}{T_2} = \frac{s_2}{T_1} \Rightarrow s_1 \times T_1 = s_2 \times T_2$$

$$\Rightarrow s \times 8 = (s + 5) \times \frac{20}{3}$$

$$\Rightarrow 24s = 20(s + 5)$$

$$\therefore s = 25 \text{ km/hr.}$$

14. Ans. (c)

Here, $s_1 = 42$ and $s_2 = 28$.

$$\therefore \text{Stoppage time/hr} = \frac{s_1 - s_2}{s_1} = \frac{42 - 28}{42}$$

$$= \frac{1}{3} \text{ hour} = 20 \text{ minutes}$$

15. Ans. (a)

Speed of the train

$$= \frac{\text{Length of the train}}{\text{Total time taken in crossing the post}}$$

\therefore Length of the train = Speed of the train
 \times Time taken in crossing the post

$$= \left(54 \times \frac{5}{18} \right) \times 9 = 135 \text{ m}$$

16. Ans. (b)

We have, speed of the train

$$\frac{\text{Length of the train} + \text{Length of the platform}}{\text{Time taken in crossing the platform}}$$

$$= \frac{50 + 100}{10} = 15 \text{ sec.}$$

17. Ans. (b)

Here, $L_1 = 300$ m, $L_2 = 200$ m,

$s_1 = 90$ km/hr and $s_2 = 60$ km/hr

$$\therefore s_1 - s_2 = 90 - 60 = 30 \text{ km/hr} = 30 \times \frac{5}{18} \text{ m/s}$$

$$\therefore \text{Time taken} = \frac{L_1 + L_2}{s_1 - s_2} = \frac{300 + 200}{30 \times \frac{5}{18}}$$

$$= \frac{500 \times 18}{30 \times 5} = 60 \text{ sec.}$$

18. Ans. (c)

Let the speed of each train be x m/sec

We have, $L_1 = L_2 = 135$ m

and $S_1 = S_2 = x$ m/sec

$$\therefore \text{Therefore time taken} = \frac{L_1 + L_2}{S_1 + S_2}$$

$$\Rightarrow 18 = \frac{135 + 135}{x + x}$$

$$\text{or, } x = \frac{270}{2 \times 18} \text{ m/s}$$

$$= \frac{270}{2 \times 18} \times \frac{18}{5} \text{ km/hr} = 27 \text{ km/hr.}$$

19. Ans. (c)

Relative speed = $(50 - 30)$ km/hr = 20 km/hr

$$= \left(20 \times \frac{5}{18} \right) = \left(\frac{50}{9} \right) \text{ m/sec.}$$

Distance covered in 18 sec at this speed

$$= \left(18 \times \frac{50}{9} \right) \text{ m} = 100 \text{ m.}$$

∴ Length of faster train = 100 m.

20. Ans. (a)

Speed of the faster train

$$= \left(\frac{L_1 + L_2}{2} \right) \left(\frac{T_1 + T_2}{T_1 T_2} \right) = \left(\frac{130 + 110}{2} \right) \left(\frac{60 + 3}{60 \times 3} \right)$$

$$= 42 \text{ m/sec.}$$

Speed of the slower train

$$\left(\frac{L_1 + L_2}{2} \right) \times \left(\frac{T_1 - T_2}{T_1 T_2} \right)$$

$$= \left(\frac{130 + 110}{2} \right) \left(\frac{60 - 3}{60 \times 3} \right) = 38 \text{ m/sec}$$

21. Ans. (d)

Time from 7 A.M. to 8 A.M. = 1 hour.

Therefore, time of their meeting

$$= \left(\frac{d + s_2 T}{s_1 + s_2} \right) \text{ hr} = \left(\frac{100 + 25 \times 1}{20 + 25} \right) \text{ hr}$$

= 2 hrs 47 min after 7 A.M.

22. Ans. (b)

Distance between Mumbai and Pune

$$= d \left(\frac{s_1 + s_2}{s_1 - s_2} \right) \text{ km}$$

$$= 20 \left(\frac{60 + 40}{60 - 40} \right) \text{ km} = 100 \text{ km.}$$

23. Ans. (a)

Let speeds of the boy and the car be x km/hr and y km/hr. respectively

$$\text{Then, } \frac{12/1000}{x} = \frac{36/1000}{y}$$

$$\therefore \frac{x}{y} = \frac{1}{3}$$

24. Ans. (b)

Let the required speed be x km/hr.

$$\text{Then, } \frac{2 \times 64 \times x}{64 + x} = 56$$

$$\therefore 128x = 64 \times 56 + 56x$$

$$\therefore x = \frac{64 \times 56}{72} = 49.77 \text{ km/hr}$$

25. Ans. (b)

Due to stoppages, it covers 9 km less per hour.

$$\text{Time taken to cover 9 km} = \left(\frac{9}{54} \times 60 \right) \text{ min}$$

$$= 10 \text{ min.}$$

So, the bus stops for 10 min. per hr.

26. Ans. (a)

Distance travelled in 2 minutes

$$= \left(1 + \frac{1}{2} \right) \text{ km i.e. } \frac{3}{2} \text{ kms.}$$

$$\text{Distance covered in 1 hr.} = \left(\frac{3}{2} \times \frac{60}{2} \right) \text{ km}$$

$$= 45 \text{ km}$$

∴ Speed of the train = 45 km/hr

27. Ans. (c)

28. Ans. (a)

Speed of the first man = 32 km/hr.

Time taken = $192 \div 32 = 6$ hr

Second man covers 192 km in 3 hr

∴ Speed of the second man

$$= 192 \div 3 = 64 \text{ km/hr}$$

Ratio = 32 : 64 or 1 : 2

29. Ans. (c)

$$\text{Distance already covered} = \frac{3}{4} \times 12 = 9 \text{ km}$$

$$\text{Time spent} = \frac{2}{3} \times 45 \text{ min} = 30 \text{ min}$$

$$\text{Distance left} = (12 - 9) \text{ km} = 3 \text{ km}$$

$$\text{Time left} = (45 - 30) \text{ min} = 15 \text{ min}$$

$$\therefore \text{Required speed} = \frac{3}{15/60} \text{ km/hr}$$

$$= 12 \text{ km/hr}$$

30. Ans. (a)

Let the speed of the train in km/hr = x

Then, relative speed = $(x + 6)$ km/hr

$$= (x + 6) \times \frac{5}{18} \text{ m/sec}$$

$$\therefore (x + 6) \times \frac{5}{18} \times 6 = 110$$

$$\therefore x = 60$$

$$\therefore \text{Speed of the train} = 60 \text{ km/hr.}$$



Boats & Streams

- If a man can swim downstream at 6 kmph and upstream at 2 kmph, his speed in still water is:
 - 4 km/hr
 - 2 km/hr
 - 3 km/hr
 - 2.5 km/hr
- If Anshul rows 15 km upstream and 21 km downstream taking 3 hours each time, then the speed of the stream is:
 - 1 km/hr
 - 1.5 km/hr
 - 2 km/hr
 - 12 km/hr
- If a boat goes 7 km upstream in 42 minutes and the speed of the stream is 3 kmph, then the speed of the boat in still water is:
 - 4.2 km/hr
 - 9 km/hr
 - 13 km/hr
 - 21 km/hr
- A man can row $9\frac{1}{3}$ kmph in still water and finds that it takes him thrice as much time to row up than as to row down the same distance in the river. The speed of the current is :
 - $3\frac{1}{3}$ km/hr
 - $3\frac{1}{9}$ km/hr
 - $4\frac{2}{3}$ km/hr
 - 14 km/hr
- A man can row a boat at 10 kmph in still water. If the speed of the stream is 6 kmph, the time taken to row a distance of 80 km down the stream is :
 - 8 hours.
 - 5 hours
 - 10 hours
 - 20 hours
- A boat takes 4 hours for travelling downstream from point A to point B and coming back to point A upstream. If the velocity of the stream is 2 kmph and the speed of the boat in still water is 4 kmph, what is the distance between A and B ?
 - 4 kms
 - 6 kms
 - 8 km
 - 9 km
- Speed of a boat in standing water is 9 kmph and the speed of the stream is 1.5 kmph. A man rows to a distance of 10.5 km and comes back to the starting point. The total time taken by him is:
 - 16 hours
 - 18 hours
 - 20 hours
 - 24 hours
- A man rows to a place 48 km distant and back in 14 hours. He finds that he can row 4 km with the steam in the same time as 3 km against the stream. The rate of the steam is :
 - 1 km/hr
 - 1.8 km/hr
 - 3.5 km/hr
 - 1.5 km/hr

9. A man can row three-quarters of a kilometre against the stream in $11\frac{1}{4}$ minutes and return in $7\frac{1}{2}$ minutes. The speed of the man in still water is:
 (a) 2 km/hr (b) 3 km/hr
 (c) 4 km/hr (d) 5 km/hr
10. A man can row 5 kmph in still water. If the river is running at 1 kmph, it takes him 75 minutes to row to a place and back. How far is the place?
 (a) 3km (b) 2.5 km
 (c) 4 km (d) 5 km

Solutions

1. Ans. (a)

$$\text{Speed in still water} = \frac{1}{2}(6+2) \text{ kmph}$$

$$= 4 \text{ kmph.}$$

2. Ans. (a)

$$\text{Rate upstream} = \left(\frac{15}{3}\right) \text{ kmph} = 5 \text{ kmph.}$$

$$\text{Rate downstream} = \left(\frac{21}{3}\right) \text{ kmph} = 7 \text{ kmph.}$$

$$\therefore \text{Speed of stream} = \frac{1}{2}(7-5) \text{ kmph}$$

$$= 1 \text{ kmph.}$$

3. Ans. (c)

$$\text{Rate upstream} = \left(\frac{7}{42} \times 60\right) \text{ kmph} = 10 \text{ kmph}$$

$$\text{Speed of stream} = 3 \text{ kmph.}$$

$$\text{Let speed in still water be } x \text{ km/hr}$$

$$\text{Then speed upstream} = (x-3) \text{ km/hr.}$$

$$\therefore x-3=10 \text{ or } x=13 \text{ kmph.}$$

4. Ans. (c)

Let speed upstream be x kmph.

Then, speed downstream = $3x$ kmph.

$$\therefore \text{speed in still water} = \frac{1}{2}(3x+x) \text{ kmph}$$

$$= 2x \text{ kmph}$$

$$\therefore 2x = \frac{28}{3} \Rightarrow x = \frac{14}{3}$$

$$\therefore \text{Speed upstream} = \frac{14}{3} \text{ km/hr,}$$

$$\text{Speed downstream} = 14 \text{ km/hr}$$

\therefore Speed of the current

$$= \frac{1}{2}\left(14 - \frac{14}{3}\right) \text{ km/hr}$$

$$= \frac{14}{3} \text{ km/hr} = 4\frac{2}{3} \text{ km/hr}$$

5. Ans. (b)

$$\text{Speed downstream} = (10+6) \text{ km/hr}$$

$$= 16 \text{ km/hr.}$$

Time taken to cover 80 km downstream

$$= \left(\frac{80}{16}\right) \text{ hrs} = 5 \text{ hrs.}$$

6. Ans. (b)

Let the distance between A and B be x km

Speed downstream = 6 kmph,

speed upstream = 2 kmph.

\therefore Distance A B = 6 km.

7. Ans. (d)

Speed upstream = 7.5 kmph,

speed downstream = 10.5 kmph.

$$\therefore \text{Total time taken} = \left(\frac{105}{7.5} + \frac{105}{10.5}\right) \text{ hrs}$$

$$= 24 \text{ hours}$$

8. Ans. (a)

Suppose he moves 4 km downstream in x hours. Then, speed downstream = $\left(\frac{4}{x}\right)$ km/hr,speed upstream = $\left(\frac{3}{x}\right)$ km/hr.

$$\therefore \frac{48}{(4/x)} + \frac{48}{(3/x)} = 14 \quad \text{or } x = \frac{1}{2}$$

 \therefore Speed downstream = 8 km/hr.

Speed upstream = 6 km/hr

$$\text{Rate of the stream} = \frac{1}{2}(8 - 6) \text{ km/hr}$$

$$= 1 \text{ km/hr.}$$

9. Ans. (d)

$$\text{Speed upstream} = \left(\frac{3}{4} \times \frac{4}{45} \times 60\right) \text{ kmph}$$

$$= 4 \text{ kmph.}$$

$$\text{Speed downstream} = \left(\frac{3}{4} \times \frac{2}{15} \times 60\right) \text{ kmph}$$

$$= 6 \text{ kmph}$$

$$\text{Speed in still water} = \frac{1}{2}(6 + 4) \text{ kmph}$$

$$= 5 \text{ kmph.}$$

10. Ans. (a)

Speed downstream = $(5 + 1)$ km/hr = 6 km/hr.Speed upstream = $(5 - 1)$ km/hr = 4 km/hr.Let the required distance be x km

$$\text{Then, } \frac{x}{6} + \frac{x}{4} = \frac{75}{60} \text{ or, } 2x + 3x = 15 \text{ or } x = 3.$$

 \therefore Required distance = 3 km.

Problems on Trains

1. A train moves with a speed of 108 kmph. Its speed in metres per second is:

- (a) 38.8 (b) 18
(c) 30 (d) 10.8

2. A speed of 14 metres per second is the same as:

- (a) 50.4 km/hr (b) 28 km/hr
(c) 70 km/hr (d) 46.6 km/hr

3. A man on riding crosses a bridge in 5 minutes when riding is being done at 15 kmph. The length of the bridge is :

- (a) 125m (b) 250 m
(c) 1250 m (d) 2500 m

4. A train 280 m long, running with a speed of 63 km/hr will pass an electric pole in:

- (a) 20 sec (b) 16 sec.
(c) 15 sec (d) 18 sec

5. A train is moving at a speed of 132 kmph. If the length of the train is 110 metres, how long will it take to cross a railway platform 165 m long?

- (a) 5 sec (b) 7.5 sec
(c) 10 sec (d) 15 sec.

6. A train 700 m long is running at 72 kmph. If it crosses a tunnel in 1 minute, the length of the tunnel is :

- (a) 700 m (b) 600 m
(c) 550 m (d) 500 m

7. If 200 m long train crosses a platform of the same length as that of the train in 20 seconds, then the speed of the train is :

- (a) 50 km/hr (b) 60 km/hr
(c) 72 km/hr (d) 80 km/hr

8. A train 300 m long crossed a platform 900 m long in 1 minute 12 seconds. The speed of the train (in km/hr) is:

- (a) 45 (b) 50
(c) 54 (d) 60

9. A train of length 150 m takes 40.5 seconds to cross a tunnel of length 300 m. The speed of the train (in km/hr) is:
 (a) 13.33 (b) 26.67
 (c) 40 (d) 400
10. A train speeds past a pole in 15 seconds and a platform 100 m long in 25 seconds. Its length is :
 (a) 200 m (b) 150 m
 (c) 50 m (d) Data inadequate
11. If a train 110 m long passes a telegraph pole in 3 seconds, then the time taken by it to cross a railway platform 165 m long is:
 (a) 3 sec (b) 4 sec
 (c) 5 sec (d) 7.5 sec
12. A train 150 m long moving at a speed of 25 metres per second overtakes a man moving at 5 metres/sec in opposite direction. The train will pass the man in:
 (a) 5 sec (b) 6 sec
 (c) $4\frac{2}{7}$ sec (d) 8 sec
13. Two trains 200 m and 150 m long are running on parallel rails at the rate of 40 kmph and 45 kmph respectively. In how much time will they cross each other, if they are running in the same direction?
 (a) 72 sec. (b) 132 sec
 (c) 192 sec. (d) 252 sec.
14. Two train 126 m and 114 m long are running in opposite directions, one at the rate of 30 kmph and another one at 42 kmph. From the moment they meet will cross each other in:
 (a) 10 sec (b) 11 sec.
 (c) 12 sec (d) 13 sec.
15. A train 110 m long passes a man, running at 6 kmph in the direction opposite to that of the train, in 6 seconds. The speed of the train is:
 (a) 60 km/hr (b) 66 km/hr
 (c) 54 km/hr (d) 72 km/hr
16. A train 108 m long moving at a speed of 50 km/hr crosses a train 112 m long coming from opposite direction in 6 seconds. The speed of the second train is:
 (a) 48 kmph (b) 54 kmph
 (c) 66 kmph (d) 82 kmph
17. A train B speeding with 120 kmph crosses another train C, running in the same direction in 2 minutes. If the lengths of the trains B and C be 100 m and 200m respectively, what is the speed of the train C?
 (a) 111 kmph (b) 127 kmph
 (c) 123 kmph (d) 129 kmph
18. Two trains travel in opposite directions at 36 kmph and 45 kmph and a man sitting in slower train passes the faster train in 8 seconds. The length of the faster train is:
 (a) 80 m (b) 100 m
 (c) 120 m (d) 180m
19. A train running at certain speed crosses a stationary engine in 20 seconds. To find out the speed of the train, which of the following information is necessary:
 (a) Only the length of the train
 (b) Only the length of the engine
 (c) Either the length of the train or the length of the engine
 (d) Both the length of the train and the length of the engine
20. A train overtakes two persons who are walking in the same direction in which the train is going, at the rate of 2 kmph and 4 kmph and passes them completely in 9 and 10 seconds. respectively. The length of the train is:
 (a) 72 m (b) 54 m
 (c) 50 m (d) 45 m
21. Two stations A and B are 110 km apart on a straight line. One train starts from A at 7 a.m.

and travels towards B at 20 kmph. Another train starts from B at 8 a.m. and travels towards A at a speed of 25 kmph. At what time will they meet?

- (a) 9 a.m. (b) 10 a.m.
(c) 11 a.m. (d) 10.30 a.m

22. Two train are running in opposite directions towards each other with speeds of 54 kmph and 48 kmph respectively. If the length of the train is 250 m and they cross each other in 18 seconds, the length of the other trains is:

- (a) 145 m (b) 230m
(c) 260 m (d) 180 m

23. A train travelling at 48 kmph completely crosses another train having half its length and travelling in opposite direction at 42 kmph, in 12 seconds. It also passes a railway platform in 45 seconds. The length of the platform is :

- (a) 560 m (b) 400 m
(c) 600 m (d) 450 m

24. A train of length 150 m takes 10 seconds to pass over another train 100 m long coming from the opposite direction. If the speed of the first train be 30 kmph, the speed of the second train is :

- (a) 36 kmph (b) 54 kmph
(c) 60 kmph (d) 72 kmph

25. A man sees a train passing over a bridge 1 km long. The length of the train is half that of the bridge. If the train clears the bridge in 2 minutes, the speed of the train is :

- (a) 30 km/hr (b) 45 km/hr
(c) 50 km/hr (d) 60 km/hr

□□□□

Solutions

1. Ans. (c)

$$108 \text{ kmph} = \left(108 \times \frac{5}{18}\right) \text{ m/sec} = 30 \text{ m/sec.}$$

2. Ans. (a)

$$14 \text{ m/sec.} = \left(14 \times \frac{18}{5}\right) \text{ km/hr} = 50.4 \text{ km/hr.}$$

3. Ans. (c)

$$\text{Speed} = \left(15 \times \frac{5}{18}\right) \text{ m/sec} = \frac{25}{6} \text{ m/sec.}$$

$$\text{Time} = (5 \times 60) \text{ sec} = 300 \text{ sec.}$$

$$\therefore \text{Length of bridge} = (\text{speed} \times \text{Time})$$

$$= \left(\frac{25}{6} \times 300\right) \text{ m} = 1250 \text{ m}$$

4. Ans. (b)

$$\text{Speed} = \left(63 \times \frac{5}{18}\right) \text{ m/sec} = \frac{35}{2} \text{ m/sec.}$$

$$\text{Time taken} = \left(280 \times \frac{2}{35}\right) \text{ sec} = 16 \text{ sec.}$$

5. Ans. (b)

$$\text{Speed} = \left(132 \times \frac{5}{18}\right) \text{ m/sec} = \frac{110}{3} \text{ m/sec.}$$

$$\text{Total distance covered} = (110 + 165) \text{ m} = 275 \text{ m.}$$

$$\therefore \text{Required time} = \left(275 \times \frac{3}{110}\right) \text{ sec.}$$

$$= 7.5 \text{ seconds.}$$

6. Ans. (d)

$$\text{Speed} = \left(72 \times \frac{5}{18}\right) \text{ m/sec} = 20 \text{ m/sec.}$$

$$\text{Time} = 60 \text{ sec.}$$

$$\therefore \frac{700+x}{20} = 60 \Leftrightarrow 700+x = 1200$$

$$\Rightarrow x = 500\text{m}$$

7. Ans. (c)

$$\text{Total distance covered} = (200 + 200)\text{m} \\ = 400\text{m.}$$

$$\text{Time taken} = 20 \text{ sec.}$$

$$\therefore \text{Speed} = \left(\frac{400}{20}\right) \text{m/sec}$$

$$= \left(20 \times \frac{18}{5}\right) \text{km/hr} = 72 \text{ km/hr.}$$

8. Ans. (d)

$$\text{Total distance covered} = (300 + 900)\text{m} \\ = 1200\text{m.}$$

$$\text{Time taken} = 1 \text{ min. } 12 \text{ sec} = 72 \text{ sec,}$$

$$\therefore \text{Speed} = \left(\frac{1200}{72}\right) \text{m/sec.}$$

$$= \left(\frac{1200}{72} \times \frac{18}{5}\right) \text{km/hr} = 60 \text{ km/hr}$$

9. Ans. (c)

$$\text{Total distance covered} = (150 + 300)\text{m} \\ = 450\text{m.}$$

$$\text{Time taken} = \left(\frac{81}{2}\right) \text{seconds.}$$

$$\text{Speed} = \left(450 \times \frac{2}{81}\right) \text{m/sec}$$

$$= \left(450 \times \frac{2}{81} \times \frac{18}{5}\right) \text{kmph} = 40 \text{ kmph}$$

10. Ans. (b)

Let the length of train be x metres and its speed by y metres/sec.

$$\text{Then, } \frac{x}{y} = 15 \Rightarrow y = \frac{x}{15}$$

$$\frac{x+100}{25} = \frac{x}{15} \Rightarrow x = 150 \text{ m/s}$$

11. Ans. (d)

$$\text{Speed} = \left(\frac{110}{3}\right) \text{m/sec}$$

Time taken to cross railway platform

$$= \left[(110+165) \times \frac{3}{110}\right] \text{sec.}$$

$$= \left(275 \times \frac{34}{110}\right) \text{sec. } 7.5 \text{ sec.}$$

12. Ans. (a)

Speed of train relative to man

$$= (25+5) \text{ m/sec}$$

$$= 30 \text{ m/sec.}$$

\therefore Time taken to pass the man

$$= \left(\frac{150}{30}\right) \text{sec} = 5 \text{ sec.}$$

13. Ans. (d)

Relative speed = $(45-40)$ kmph = 5 kmph.

$$= \left(5 \times \frac{5}{18}\right) \text{m/sec} = \left(\frac{25}{18}\right) \text{m/sec}$$

Total distance covered = Sum of length of trains = 350 m

$$\therefore \text{Time taken} = \left(350 \times \frac{18}{25}\right) \text{sec.} = 252 \text{ sec.}$$

14. Ans. (c)

Relative speed = $(30+42)$ kmph = 72 kmph

$$= \left(72 \times \frac{5}{18}\right) \text{m/sec} = 20 \text{ m/sec}$$

Distance covered in crossing each other

$$= (126 + 114) \text{ m} = 240 \text{ m.}$$

$$\text{Required time} = \left(\frac{240}{20}\right) \text{sec} = 12 \text{ Seconds.}$$

15. Ans. (a)

Speed of the train relative to man

$$= \left(\frac{110}{6} \right) \text{m/sec.}$$

$$= \left(\frac{110}{6} \times \frac{18}{5} \right) \text{kmph} = 66 \text{ kmph.}$$

Let the speed of the train be x kmph.Then, relative speed = $(x + 6)$ kmph.

$$x + 6 = 66 \text{ or } x = 60 \text{ kmph.}$$

16. Ans. (d)

Let the speed of the second train be x kmphRelative speed = $(x + 50)$ kmph

$$= \left[(x + 50) \times \frac{5}{18} \right] \text{m/sec.}$$

$$= \left(\frac{250 + 5x}{18} \right) \text{m/sec.}$$

Distance covered = $(108 + 112) = 220$ m.

$$\therefore \frac{220}{\left(\frac{250 + 5x}{18} \right)} = 6 \text{ or } 250 + 5x = 660$$

$$\text{or } x = 82 \text{ kmph}$$

17. Ans. (a)

Let the speed of train C be x kmph.Speed of B relative to C = $(120 - x)$

$$= \left[(120 - x) \times \frac{5}{18} \right] \text{m/sec}$$

$$= \left(\frac{600 - 5x}{18} \right) \text{m/sec}$$

Distance covered = $(100 + 200)$ m = 300m.

$$\therefore \frac{300}{\left(\frac{600 - 5x}{18} \right)} = 120 \Rightarrow 5400$$

$$= 120(600 - 5x) \Rightarrow x = 111.$$

18. Ans. (d)

Relative speed = $(36 + 54)$ km/hr

$$= \left(81 \times \frac{5}{18} \right) \text{m/sec} = \left(\frac{45}{2} \right) \text{m/sec.}$$

$$\text{Length of train} = \left(\frac{45}{2} \times 8 \right) \text{m} = 180 \text{ m.}$$

19. Ans. (d)

Since the sum of the lengths of the train and the engine is needed, so both the lengths must be known

20. Ans. (c)

$$2 \text{ kmph} = \left(2 \times \frac{5}{18} \right) \text{m/sec}$$

$$= \frac{5}{9} \text{ m/sec} \text{ \& } 4 \text{ kmph} = \frac{10}{9} \text{ m/sec.}$$

Let the length of the train be x metres & its speed by y m/sec.

$$\text{Then, } \frac{x}{\left(y - \frac{5}{9} \right)} = 9 \text{ and } \frac{x}{\left(y - \frac{10}{9} \right)} = 10.$$

$$\therefore 9y - 5 = \frac{x}{9} \text{ and } 10(9y - 10) = 9x$$

$$\therefore 9y - x = 5 \text{ and } 90y - 9x = 100$$

On solving we get $x = 50$.

$$\therefore \text{Length of the train is } 50 \text{ m.}$$

21. Ans. (b)

Suppose they meet x hours after 7 a.m.Distance covered by A in x hours

$$= 20x \text{ km.}$$

Distance covered by B in $(x - 1)$ hours

$$= 25(x - 1) \text{ km}$$

$$\therefore 20x + 25(x - 1) = 110$$

$$\text{or } 45x = 135 \text{ or } x = 3.$$

So, they meet at 10 a.m.

22. Ans. (c)

Relative speed = $(54 + 48)$ kmph

$$= \left(102 \times \frac{5}{18}\right) \text{m/sec} = \left(\frac{85}{3}\right) \text{m/sec.}$$

Let the length of the other train be x metres.

$$\text{Then, } (250 + x) \times \frac{3}{85} = 18 \text{ or } 750 + 3x$$

$$= 1530 \text{ or } x = 260\text{m}$$

\therefore The length of the other train is 260 m.

23. Ans. (b)

Let the length of first train be x metres.

Then, the length of second train is $(x/2)$ metres.

Relative speed = $(48 + 42)$ kmph

$$= \left(90 \times \frac{5}{18}\right) \text{m/sec} = 25 \text{ m/sec.}$$

$$\therefore \frac{\left(x + \frac{x}{2}\right)}{25} = 12 \text{ or } \frac{3x}{2} = 300$$

or $x = 200$.

\therefore Length of first train = 200m.

Let the length of platform be y metres.

Speed of the first train

$$= \left(48 \times \frac{5}{18}\right) \text{m/sec} = \frac{25}{3} \text{m/sec.}$$

$$\therefore (200 + y) \times \frac{3}{40} = 45 \Rightarrow 600 + 3y$$

$$= 1800 \Rightarrow y = 400\text{m.}$$

24. Ans. (c)

Let the speed of second train be x kmph.

Relative speed = $(30 + x)$ kmph

$$= (30 + x) \times \frac{5}{18} \text{m/sec}$$

$$(150 + 100) \times \frac{18}{5(30 + x)} = 10$$

$$\Rightarrow x = 60$$

25. Ans. (b)

Length of bridge = 1000 m.

Length of train = 500 m.

Total distance covered in clearing the bridge = 1500m.

Time taken = 120 seconds.

$$\therefore \text{Speed} = \left(\frac{1500}{120}\right) \text{m/sec}$$

$$= \left(\frac{25}{2} \times \frac{18}{5}\right) \text{kmph} = 45 \text{ kmph.}$$





B

Section

Algebra & Geometry





Surds, Indices & Logarithms

LAWS OF INDICES

(1) $a^m \times a^n = a^{m+n}$

Example

$\rightarrow 2^4 \times 2^{13} = 2^{17}$

$\rightarrow 3^8 \times 3^7 = 3^{15}$

(2) $\frac{a^m}{a^n} = a^{m-n}$

Example

(i) $\frac{7^5}{7^2} = 7^{5-2} = 7^3$

(ii) $\frac{27^5}{27^2} = 27^3$

(3) $(a^m)^n = a^{mn}$

Example

(i) $(3^2)^4 = 3^{2 \times 4} = 3^8$

(ii) $(5^3)^9 = 5^{3 \times 9} = 5^{27}$

(4) $(a \times b)^n = a^n \times b^n$

Example

(i) $(3 \times 5)^2 = 3^2 \times 5^2$

(ii) $(4 \times 5)^3 = 4^3 \times 5^3$

(5) $\left(\frac{a}{b}\right)^n = \frac{a^n}{b^n}$

Example

(i) $\left(\frac{3}{4}\right)^2 = \frac{3^2}{4^2} = \frac{9}{16}$

(ii) $\left(\frac{5}{8}\right)^3 = \frac{5^3}{8^3} = \frac{125}{512}$

(6) $a^0 = 1$

here a may be any number

Example

(i) $5^0 = 1$

(ii) $1000^0 = 1$

(7) $a^x = a^y$

If and only if Condition

Example

(i) $x = y$ or

(ii) $x = 0, y = 0$

(8) $a^{-m} = \frac{1}{a^m}$

Example

(i) $4^{-2} = \frac{1}{4^2} = \frac{1}{16}$

$$(ii) 5^{-3} = \frac{1}{5^3} = \frac{1}{125}$$

$$(9) a^{-1} = \frac{1}{a}$$

$$\text{Example } 10^{-1} = \frac{1}{10}$$

Example

$$(i) \sqrt[2]{\sqrt[3]{4\sqrt{10}}} = 10^{\frac{1}{2 \times 3 \times 4}} = 10^{\frac{1}{24}}$$

$$(ii) \sqrt[3]{\sqrt[5]{25}} = 25^{\frac{1}{3 \times 5}} = 25^{\frac{1}{15}}$$

□□□□

Laws of Surds

We write $\sqrt[n]{a} = a^{1/n}$ and it is called a surd of order 'n'

$$(1) (\sqrt[n]{a})^n = (a^{1/n})^n = a$$

$$(2) \sqrt[n]{ab} = \sqrt[n]{a} \cdot \sqrt[n]{b}$$

Example

$$(i) \sqrt[3]{2 \times 5} = \sqrt[3]{2} \times \sqrt[3]{5}$$

$$(ii) \sqrt[5]{7 \times 13} = \sqrt[5]{7} \times \sqrt[5]{13}$$

$$(3) \sqrt[n]{\frac{a}{b}} = \frac{\sqrt[n]{a}}{\sqrt[n]{b}}$$

Example

$$(i) \sqrt[3]{\frac{2}{5}} = \frac{\sqrt[3]{2}}{\sqrt[3]{5}}$$

$$(ii) \sqrt[5]{\frac{7}{13}} = \frac{\sqrt[5]{7}}{\sqrt[5]{13}}$$

$$(4) (\sqrt[n]{a})^m = \sqrt[n]{a^m}$$

Example

$$(i) (\sqrt[3]{2})^5 = \sqrt[3]{2^5} = \sqrt[3]{32}$$

$$(ii) (\sqrt[5]{4})^3 = \sqrt[5]{4^3} = \sqrt[5]{64}$$

$$(5) \sqrt[m]{\sqrt[n]{\sqrt[p]{a}}} = \sqrt[mnp]{a} = a^{\frac{1}{mnp}}$$



Solved Examples

1. Find the value of $\left(\frac{32}{343}\right)^{-3/5}$

$$\begin{aligned} \text{Sol.: } \left(\frac{32}{343}\right)^{-3/5} &= \left(\frac{2^5}{3^5}\right)^{-3/5} = \left(\frac{2}{3}\right)^{5 \times \frac{-3}{5}} \\ &= \left(\frac{2}{3}\right)^{-3} = \left(\frac{3}{2}\right)^3 = \frac{27}{8} \end{aligned}$$

2. Solve $4^{3x-2} \cdot 8 = 1$

$$\begin{aligned} \text{Sol.: } 4^{3x-2} \times 8 &= (2^2)^{3x-2} \times 2^3 = 1 \\ &= 2^{6x-4+3} = 1 \\ &= 2^{6x-1} = 2^0 \quad [\because 2^0 = 1] \\ &= 2^{6x-1} = 2^0 \Rightarrow x = \frac{1}{6} \end{aligned}$$

3. Find the value of x if $\left(\frac{a}{b}\right)^{3x-5} = \left(\frac{b}{a}\right)^{x+3}$

$$\begin{aligned} \text{Sol.: } \left(\frac{a}{b}\right)^{3x-5} &= \left(\left(\frac{a}{b}\right)^{-1}\right)^{x+3} \\ &= \left(\frac{a}{b}\right)^{3x-5} = \left(\frac{a}{b}\right)^{-x-3} \\ &= 3x-5 = -x-3 \end{aligned}$$

$$= 4x = 2 \Rightarrow x = \frac{1}{2}$$

4. Which is greater $\sqrt[4]{4}$ or $\sqrt[5]{5}$

$$\text{Sol.: } \sqrt[4]{4} = 4^{\frac{1}{4}} \text{ and } \sqrt[5]{5} = 5^{\frac{1}{5}}$$

Now the LCM of 4 & 5 is 20, so to compare two surds raise the power by 20.

$$\left(4^{\frac{1}{4}}\right)^{20} = 4^5 = 1024$$

$$\left(5^{\frac{1}{5}}\right)^{20} = 5^4 = 625$$

hence, $\sqrt[4]{4} > \sqrt[5]{5}$

5. Simplify, $\frac{\sqrt{8} + \sqrt{2}}{\sqrt{8} - \sqrt{2}}$

$$\text{Sol.: } \frac{\sqrt{8} + \sqrt{2}}{\sqrt{8} - \sqrt{2}} \times \frac{\sqrt{8} + \sqrt{2}}{\sqrt{8} + \sqrt{2}}$$

(Multiply numerator & denominator by conjugate of denominator)

$$= \frac{(\sqrt{8} + \sqrt{2})^2}{(\sqrt{8})^2 - (\sqrt{2})^2} = \frac{8 + 2 + 2\sqrt{16}}{8 - 2}$$

$$= \frac{10 + 8}{6} = 3 \text{ Ans.}$$

6. Simplify $\frac{\sqrt{5} - \sqrt{3}}{\sqrt{5} + \sqrt{3}}$

Sol.: Multiplying numerator & denominator of above equation by $\sqrt{5} - \sqrt{3}$ we get

$$\frac{\sqrt{5} - \sqrt{3}}{\sqrt{5} + \sqrt{3}} \times \frac{\sqrt{5} - \sqrt{3}}{\sqrt{5} - \sqrt{3}}$$

$$= \frac{5 + 3 - 2\sqrt{15}}{5 - 3} = \frac{8 - 2\sqrt{15}}{2} = 4 - \sqrt{15}$$

7. Simplify $\frac{\sqrt{a^2+1} + \sqrt{a^2-1}}{\sqrt{a^2+1} - \sqrt{a^2-1}}$

Sol.:

$$\frac{\sqrt{a^2+1} + \sqrt{a^2-1}}{\sqrt{a^2+1} - \sqrt{a^2-1}} \times \frac{\sqrt{a^2+1} + \sqrt{a^2-1}}{\sqrt{a^2+1} + \sqrt{a^2-1}}$$

$$= \frac{a^2+1+a^2-1+2(\sqrt{a^2+1})(\sqrt{a^2-1})}{a^2+1-(a^2-1)}$$

$$= \frac{2a^2 + 2\sqrt{a^4-1}}{2} = a^2 + \sqrt{a^4-1}$$

8. Which is greater $\sqrt[3]{4}$ or $\sqrt[4]{5}$

$$\text{Sol.: } \sqrt[3]{4} = 4^{\frac{1}{3}} \text{ and } \sqrt[4]{5} = 5^{\frac{1}{4}}$$

raise the power of both the surds by 12(LCM of 3 and 4)

$$\left(4^{\frac{1}{3}}\right)^{12} = 4^4 = 256$$

$$\left(5^{\frac{1}{4}}\right)^{12} = 5^3 = 125$$

Hence, $\sqrt[3]{4} > \sqrt[4]{5}$

9. If $2^{2x-1} = \frac{1}{8^{x-3}}$ then find value of x

$$\text{Sol.: } 2^{2x-1} = \frac{1}{8^{x-3}}$$

$$= 2^{2x-1} = \frac{1}{(2^3)^{x-3}} = \frac{1}{2^{3x-9}}$$

$$= 2^{2x-1} = 2^{-3x+9} \left[\because \frac{1}{a^m} = a^{-m} \right]$$

$$= 5x = 10, x = 2$$

10. Find the value of x if $\sqrt[3]{32} = 2^x$

$$\begin{aligned}\text{Sol.: } \sqrt[3]{32} &= 32^{1/3} = (2^5)^{1/3} \\ &= 2^{5/3} = 2^x, \quad x = 5/3\end{aligned}$$

11. If $2^x = 3^y = 6^{-z}$ then $\left(\frac{1}{x} + \frac{1}{y} + \frac{1}{z}\right)$ is equal to?

$$\text{Sol.: let } 2^x = 3^y = 6^{-z} = k$$

$$\text{So, } 2 = k^{1/x}, \quad 3 = k^{1/y}, \quad 6 = k^{-1/z}$$

We know that $2 \times 3 = 6$ this gives

$$k^{1/x} \times k^{1/y} = k^{-1/z} = \frac{1}{x} + \frac{1}{y} = -\frac{1}{z}$$

$$= \frac{1}{x} + \frac{1}{y} + \frac{1}{z} = 0$$

12. Arrange $\sqrt{2}$, $\sqrt[3]{4}$ and $\sqrt[4]{6}$ in ascending order

$$\text{Sol.: } \sqrt{2} = 2^{1/2}$$

$$\sqrt[3]{4} = 4^{1/3}, \quad \sqrt[4]{6} = 6^{1/4}$$

Now raise the power of given surds by LCM of 2, 3, 4 that is 12

$$\left(2^{1/2}\right)^{12} = 2^6 = 64$$

$$\left(4^{1/3}\right)^{12} = 4^4 = 256$$

$$\left(6^{1/4}\right)^{12} = 6^3 = 216$$

$$\text{Ans: } \sqrt{2}, \sqrt[4]{6}, \sqrt[3]{4}$$

Logarithms

Definition

The logarithm of any number of a given base is equal to the index to which the base should be raised to obtain the given number.

For example if

$a^x = c$, then x is called logarithm of a number c to the base a . It is written as $\log_a c = x$

Similarly

$$2^3 = 8 \text{ is similar as } \log_2 8 = 3$$

$$4^{-2} = \frac{1}{4^2} = \frac{1}{16} \text{ is written}$$

$$\text{as } \log_4 \frac{1}{16} = -2$$

$$10^3 = 1000 \Rightarrow \log_{10} 1000 = 3$$

$$3^5 = 243 \Rightarrow \log_3 243 = 5$$

PROPERTIES OF LOGARITHMS

$$(a) \log_a (m \times n) = \log_a m + \log_a n$$

Example:

$$\log_{10} (15) = \log_{10} 3 + \log_{10} 5$$

$$(b) \log_a \left(\frac{m}{n}\right) = \log_a (m) - \log_a (n)$$

Example:

$$\log_2 \left(\frac{6}{5}\right) = \log_2 6 - \log_2 5$$

$$(c) \log_a (m^n) = n \log_a m$$

Example:

$$\log_5 625 = \log_5 5^4 = 4 \log_5 5$$

$$(d) \log_{a^n} (m) = \frac{1}{n} \log_a (m)$$

Example:

$$\log_2(8) = \frac{1}{4} \log_2 8$$

$$(2) \log_{10^2} 1000 = \frac{1}{2} \log_{10} 1000$$

$$(e) \log_a b = \frac{\log_n b}{\log_n a}$$

[here n may be any natural number]

Example:

$$\log_2 5 = \frac{\log_{10} 5}{\log_{10} 2}$$

$$\log_2 16 = \frac{\log_{10} 16}{\log_{10} 2}$$

$$(f) \log_a x = \frac{\log_n x}{\log_n a} = \frac{1}{\log_x a}$$

Example:

$$\log_2 5 = \frac{1}{\log_5 2}$$

$$\log_3 8 = \frac{1}{\log_8 3}$$

$$(g) \log_a b \times \log_b a = \frac{\log_n b}{\log_n a} \times \frac{\log_n a}{\log_n b} = 1$$

Example:

$$\log_3 4 \times \log_4 3 = 1$$

$$= \log_2 10 \times \log_{10} 2 = 1$$

Remark:

(1) When base is not mentioned it is taken as 10.

(2) Logarithms to the base 10 is known as common logarithms.

(3) $\log_a a = 1$

Example:

$$\log_5 5 = 1$$

$$\log_2 2 = 1$$

$$(i) \log_a 1 = 0$$

[a may be any natural number.]

$$(j) a^{\log_a x} = x$$

$$5^{\log_5 3} = 3$$

$$3^{\log_3 7} = 7$$

□□□□



Solved Examples

1. Find the logarithm of 32 to the base 2

$$\begin{aligned} \text{Sol.: } \log_2 32 &= \log_2 (2^5) \\ &= 5 \log_2 2 = 5 \times 1 = 5 \end{aligned}$$

2. If $\log_5 a = 3$ find value of a

$$\begin{aligned} \text{Sol.: } \log_5 a &= 3 \\ a &= 5^3 = 125 \end{aligned}$$

3. Find the value of $2^{\log_2 5}$

$$\begin{aligned} \text{Sol.: } a^{\log_a x} &= x \\ \text{So } 2^{\log_2 5} &= 5 \end{aligned}$$

4. Find the value of $3^{2+\log_3 5}$

$$\begin{aligned} \text{Sol.: } 3^{2+\log_3 5} &= 3^2 \times 3^{\log_3 5} \\ &= 3^2 \times 5 = 45 \end{aligned}$$

5. Find the value of $3^{2-\log_3 5}$

$$\text{Sol.: } 3^{2-\log_3 5} = \frac{3^2}{3^{\log_3 5}} = \frac{9}{5}$$

6. Find the value of $\log_5 125 - \log_4 16$

$$\begin{aligned} \text{Sol.: } \log_5 125 - \log_4 16 \\ &= \log_5 (5^3) - \log_4 (4^2) = 3 - 2 = 1 \end{aligned}$$

7. Find the value of $\log x^3 + \log x$

$$\text{Sol.: } \log x^3 + \log x = 3\log x + \log x = 3$$

$$\text{or } \frac{n}{4} = 3^2, n = 3^2 \times 4 = 36$$

8. If $\log_{16} a = \frac{1}{2}$, Find a

$$\text{Sol.: } \log_{16} a = \frac{1}{2}$$

$$a = 16^{1/2}$$

$$a = 4$$

9. $\log_a \sqrt{3} = \frac{1}{6}$, find the value of a

$$\text{Sol.: } \log_a \sqrt{3} = \frac{1}{6}$$

$$= \log_a 3^{1/2} = \frac{1}{6}$$

$$\text{or } a^{1/6} = 3^{1/2}, a = 3^3 = 27$$

10. If $\log_{27} x + \log_9 x + \log_3 x = 11$, find the value of x

$$\text{Sol.: } \log_{27} x + \log_9 x + \log_3 x = 11$$

$$= \frac{1}{3}\log_3 x + \frac{1}{2}\log_3 x + \log_3 x = 11$$

$$= \frac{11}{6}\log_3 x = 11$$

$$= \frac{1}{6}\log_3 x = 1$$

$$= \log_3 x = 6$$

$$= x = 3^6 = 729$$

11. Solve $\log_3 n - \log_3 4 = 2$

$$\text{Sol.: } \log_3 n - \log_3 4 = \log_3 \frac{n}{4} = 2$$

$$\log_3 \frac{n}{4} = 2$$

12. Find the value of $\log \frac{x^2}{yz} + \log \frac{y^2}{zx} + \log \frac{z^2}{xy}$

$$\text{Sol.: } \log \frac{x^2}{yz} + \log \frac{y^2}{zx} + \log \frac{z^2}{xy}$$

$$= \log \frac{x^2}{yz} \times \frac{y^2}{zx} \times \frac{z^2}{xy}$$

$$= \log \frac{x^2 y^2 z^2}{y^2 z^2 x^2} = \log 1 = 0$$

13. Evaluate $\log_7 \left(\frac{1}{343} \right)$

$$\text{Sol.: } \log_7 \left(\frac{1}{343} \right) = \log_7 \frac{1}{7^3}$$

$$= \log_7 7^{-3} = -3\log_7 7 = -3$$

14. Evaluate $\log_{100} (0.01)$

$$\text{Sol.: } \log_{100} (100)^{-1} = -1\log_{100} 100 = -1$$

15. If $\log_{\sqrt{8}} x = 3\frac{1}{3}$, find the value of x

$$\text{Sol.: } \log_{\sqrt{8}} x = \frac{10}{3} = \left(2^{3/2} \right)^{10/3}$$

$$= 2^{3/2 \times 10/3} = 2^5 = 32$$

□□□□

Surds, Indices & Logarithms



Practice Exercise: I

- The value of $(\sqrt{8})^{1/3}$ is:
 - 2
 - 4
 - $\sqrt{2}$
 - 8
- $\left(\frac{1}{216}\right)^{-2/3} + \left(\frac{1}{27}\right)^{-4/3} = ?$
 - $\frac{3}{4}$
 - $\frac{2}{3}$
 - $\frac{4}{9}$
 - $\frac{1}{8}$
- If $\sqrt{2^n} = 64$, then the value of n is:
 - 8
 - 4
 - 6
 - 12
- If $\frac{9^n \times 3^5 \times (27)^3}{3 \times (81)^4} = 27$, then n equals:
 - 0
 - 2
 - 3
 - 4
- If $(\sqrt{3})^5 \times 9^2 = 3^\alpha \times 3\sqrt{3}$, then α equals:
 - 2
 - 3
 - 4
 - 5
- If x, y, z are real numbers, then the value of: $\sqrt{x^{-1}y} \cdot \sqrt{y^{-1}z} \cdot \sqrt{z^{-1}x}$ is
 - xyz
 - \sqrt{xyz}
 - $\frac{1}{xyz}$
 - 1
- $\left(\frac{x^b}{x^c}\right)^{(b+c-a)} \cdot \left(\frac{x^c}{x^a}\right)^{(c+a-b)} \cdot \left(\frac{x^a}{x^b}\right)^{(a+b-c)} = ?$
 - x^{abc}
 - x^{a+b+c}
 - $x^{ab+bc+ca}$
 - 1
- If $2^{x+4} - 2^{x+2} = 3$, then x is equal to:
 - 0
 - 2
 - 1
 - 2
- If $2^{2x-1} = \frac{1}{8^{x-3}}$, the value of x is:
 - 3
 - 2
 - 0
 - 2
- If $\sqrt{5 + \sqrt[3]{x}} = 3$, then x is equal to:
 - 125
 - 64
 - 27
 - 9
- If $a^x = b^y = c^z$ and $b^2 = ac$, then y equals:
 - $\frac{xz}{x+z}$
 - $\frac{xz}{2(x-z)}$
 - $\frac{xz}{2(z-x)}$
 - $\frac{2xz}{(x+z)}$
- If $x=y^a$, $y=z^b$ and $z=x^c$, then the value of abc is:
 - 4
 - 3
 - 2
 - 1

Solutions

1. Ans. (c)

$$\begin{aligned} (\sqrt{8})^{1/3} &= (8^{1/2})^{1/3} = 8^{(1/2 \times 1/3)} = 8^{1/6} \\ &= (2^3)^{1/6} = 2^{(3 \times 1/6)} = 2^{1/2} = \sqrt{2}. \end{aligned}$$

2. Ans. (c)

$$\left(\frac{1}{216}\right)^{-2/3} + \left(\frac{1}{27}\right)^{-4/3}$$

$$= (216)^{2/3} + (27)^{4/3} = (6^3)^{2/3} + (3^3)^{4/3}$$

$$= 6\left(3 \times \frac{2}{3}\right) + 3\left(3 \times \frac{4}{3}\right) = 6^2 + 3^4 = \frac{36}{81} = \frac{4}{9}$$

3. Ans. (d)

$$\sqrt{2^n} = 64 \Rightarrow 2^{n/2} = 64 = 2^6$$

$$\therefore \frac{n}{2} = 6 \text{ or } n = 12.$$

4. Ans. (c)

$$\frac{9^n \times 3^5 \times (27)^3}{3 \times (81)^4} = 27$$

$$\Rightarrow \frac{3^{2n} \times 3^5 \times (3^3)^3}{3 \times (3^4)^4} = 3^3$$

$$\text{or } \frac{3^{2n} \times 3^5 \times 3^9}{3^1 \times 3^{16}} = 3^3$$

$$\text{or } 3^{2n+5+9} = 3^3 \times 3^1 \times 3^{16}$$

$$\text{or } 3^{2n+14} = 3^{20}$$

$$\therefore 2n + 14 = 20$$

$$\text{or } 2n = 6 \text{ or } n = 3.$$

5. Ans. (d)

$$(\sqrt{3})^5 \times 9^2 = 3^\alpha \times 3\sqrt{3}$$

$$\Rightarrow (3^{1/2})^5 \times (3^2)^2 = 3^\alpha \times 3^1 \times 3^{1/2}$$

$$\therefore 3^{5/2} \times 3^4 = 3^\alpha \times 3^1 \times 3^{1/2}$$

$$\text{or } 3^{\left(\frac{5}{2}+4\right)} = 3^{\left(\alpha+1+\frac{1}{2}\right)}$$

$$\text{or } 3^{13/2} = 3^{\alpha+3/2} \quad \text{So, } \alpha + \frac{3}{2} = \frac{13}{2}$$

$$\text{or } \alpha = \left(\frac{13}{2} - \frac{3}{2}\right) = 5.$$

6. Ans. (d)

$$\sqrt{x^{-1}y} \cdot \sqrt{y^{-1}z} \cdot \sqrt{z^{-1}x}$$

$$= \sqrt{\frac{y}{x}} \cdot \sqrt{\frac{z}{y}} \cdot \sqrt{\frac{x}{z}} = \frac{\sqrt{y}}{\sqrt{x}} \times \frac{\sqrt{z}}{\sqrt{y}} \times \frac{\sqrt{x}}{\sqrt{z}} = 1.$$

7. Ans. (d)

Given Exp.

$$= x^{(b-c)(b+c-a)} \cdot x^{(c-a)(c+a-b)} \cdot x^{(a-b)(a+b-c)}$$

$$= x^{(b^2-c^2)+(c^2-a^2)+(a^2-b^2)} \cdot x^{-a(b-c)-b(c-a)-c(a-b)}$$

$$= x^0 \cdot x^0 = 1$$

8. Ans. (d)

$$2^{x+4} - 2^{x+2} = 3$$

$$\Rightarrow 2^{x+2}(2^2 - 1) = 3$$

$$\Rightarrow 2^{x+2} = 1 = 2^0$$

$$\therefore x + 2 = 0 \text{ or } x = -2.$$

9. Ans. (b)

$$2^{2x-1} = \frac{1}{8^{x-3}} \Rightarrow 2^{2x-1} = \frac{1}{(2^3)^{(x-3)}}$$

$$\Rightarrow 2^{2x-1} = \frac{1}{2^{3x-9}} \Rightarrow 2^{2x-1} = 2^{9-3x}$$

$$\therefore 2x - 1 = 9 - 3x \text{ or } 5x = 10 \text{ or } x = 2.$$

10. Ans. (b)

On squaring both sides, we get :

$$5 + \sqrt[3]{x} = 9 \text{ or } \sqrt[3]{x} = 4.$$

Cubing both sides, we get

$$x = (4 \times 4 \times 4) = 64.$$

11. Ans. (d)

Let $a^x = b^y = c^z = k$.Then $a = k^{1/x}$, $b = k^{1/y}$ and $c = k^{1/z}$.

$$b^2 = ac \Rightarrow k^{2/y} = k^{1/x} \cdot k^{1/z}$$

$$\Rightarrow k^{2/y} = k^{\left(\frac{1}{x} + \frac{1}{z}\right)}$$

12. Ans. (d)

$$x = y^a = (z^b)^a = z^{ab} = (x^c)^{ab} = x^{abc}$$

$$\therefore abc = 1.$$

□□□□

Surds, Indices & Logarithms



Practice Exercise: II

- The value of $\log_{343} 7$ is:
(a) $\frac{1}{3}$ (b) -3
(c) $-\frac{1}{3}$ (d) 3
- The value of $\log_{10}(.0001)$ is:
(a) $\frac{1}{4}$ (b) $-\frac{1}{4}$
(c) -4 (d) 4
- If $\log_8 x = \frac{2}{3}$, then the value of x is :
(a) $\frac{3}{4}$ (b) $\frac{4}{3}$
(c) 4 (d) 3
- If $\log_x 4 = \frac{1}{4}$, then x is equal to:
(a) 16 (b) 64
(c) 128 (d) 256
- $\log_{32} x = 0.8$, then x is equal to:
(a) 25.6 (b) 16
(c) 10 (d) 12.8
- If $\log_4 x + \log_2 x = 6$, then x is equal to
(a) 2 (b) 4
(c) 8 (d) 16
- If $\log 2 = 0.30103$, then the number of digits in 5^{20} is:
(a) 14 (b) 16
(c) 18 (d) 25
- The value of $\log_2(\log_5 625)$ is:
(a) 2 (b) 5
(c) 10 (d) 15
- $(\log_b a \times \log_c b \times \log_a c)$ is equal to:
(a) 0 (b) 1
(c) abc (d) $a+b+c$
- $\left[\frac{1}{(\log_a bc)+1} + \frac{1}{(\log_b ca)+1} + \frac{1}{(\log_c ab)+1} \right]$
is equal to:
(a) 1 (b) 2
(c) 3 (d) $\frac{3}{2}$
- If $\log_2[\log_3(\log_2 x)] = 1$, then x is equal to:
(a) 512 (b) 128
(c) 12 (d) 0
- If $\log_{10} 2 = 0.3010$, then $\log_2 10$ is :
(a) .3322 (b) 3.2320
(c) 3.3222 (d) 5
- If $\log_{10} 2 = 0.3010$, the value of $\log_{10} 5$ is:
(a) 0.3241 (b) 0.6911
(c) 0.6990 (d) .7525
- The value of $(\log_9 27 + \log_8 32)$ is :
(a) 4 (b) 7
(c) $\frac{7}{2}$ (d) $\frac{19}{6}$
- The value of $16^{\log_4 5}$ is :
(a) 5 (b) 16
(c) 25 (d) $\frac{5}{64}$
- If $\log_5(x^2 + x) - \log_5(x + 1) = 2$, then the value of x is:
(a) 5 (b) 32
(c) 25 (d) 10

17. If $\log x + \log y = \log(x + y)$, then:

(a) $x = y$ (b) $xy = 1$

(c) $y = \frac{x-1}{x}$ (d) $y = \frac{x}{x-1}$

18. The value of

$$\left[\frac{1}{\log_{(p/q)} x} + \frac{1}{\log_{(q/r)} x} + \frac{1}{\log_{(r/p)} x} \right] \text{ is:}$$

(a) 3 (b) 2
(c) 1 (d) 0

19. If $\log 2 = 0.3010$ and $\log 3 = 0.4771$ then the value of $\log 4.5$ is:

(a) 0.6532 (b) 0.7727
(c) 0.3266 (d) None of these

Solutions

1. Ans. (a)

Let $\log_{343} 7 = m$.

Then, $(343)^m = 7 \Rightarrow (7^3)^m = 7$

$\Rightarrow 7^{3m} = 7$

$\Rightarrow 3m = 1 \Rightarrow m = \frac{1}{3}$.

$\therefore \log_{343} 7 = \frac{1}{3}$.

2. Ans. (c)

Let $\log_{10}(.0001) = m$. Then,

$10^m = .0001 \Rightarrow 10^m = \frac{1}{10000} \Rightarrow 10^m$

$= \frac{1}{10^4} \Rightarrow 10^m = 10^{-4} \Rightarrow m = -4$

$\therefore \log_{10}(.0001) = -4$.

3. Ans. (c)

$\log_8 x = \frac{2}{3} \Rightarrow x = 8^{2/3} = (2^3)^{2/3}$

$= 2^{(3 \times \frac{2}{3})} = 2^2 = 4$.

4. Ans. (d)

$\log_x 4 = \frac{1}{4} \Rightarrow x^{1/4} = 4 \Rightarrow x = 4^4 = 256$.

5. Ans. (b)

$\log_{32} x = 0.8 \Rightarrow x = (32)^{0.8}$

$= (2^5)^{4/5} = 2^4 = 16$.

6. Ans. (d)

$\log_4 x + \log_2 x = 6 \Rightarrow \frac{\log x}{\log 4} + \frac{\log x}{\log 2} = 6$

$\therefore \frac{\log x}{2 \log 2} + \frac{\log x}{\log 2} = 6 \Rightarrow 3 \log x = 12 \log 2$

or $\log x = 4 \log 2 \Rightarrow \log x$

$= \log 2^4$ or $x = 2^4 = 16$.

7. Ans. (a)

$\log 5^{20} = 20 \log 5 = 20 \times \left[\log \left(\frac{10}{2} \right) \right]$

$= 20 \times [\log 10 - \log 2] = 20 \times [1 - 0.3010]$

$= 20 \times 6990 = 13.9800$

\therefore Characteristic = 13.

\therefore Number of digits in 5^{20} is 14.

8. Ans. (a)

Let $\log_5 625 = x$. Then, 5^x

$= 625 = 5^4$ or $x = 4$

Let $\log_2 (\log_5 625) = y$. Then, $\log_2 (4) = y$

or $2^y = 4 = 2^2$. So, $y = 2$.

$\therefore \log_2 (\log_5 625) = 2$.

9. Ans. (b)

$$\text{Given Exp.} = \left(\frac{\log a}{\log b} \times \frac{\log b}{\log c} \times \frac{\log c}{\log a} \right) = 1.$$

10. Ans. (a)

$$\begin{aligned} &= \frac{1}{\log_a bc + \log_a a} + \frac{1}{\log_b ca + \log_b b} \\ &+ \frac{1}{\log_c ab + \log_c c} \\ &= \frac{1}{\log_a(abc)} + \frac{1}{\log_b(abc)} + \frac{1}{\log_c(abc)} \\ &= \log_{abc} a + \log_{abc} b + \log_{abc} c \\ &= \log_{abc}(abc) = 1. \end{aligned}$$

11. Ans. (a)

$$\begin{aligned} \log_2 [\log_3 (\log_2 x)] &= 1 \\ \Rightarrow \log_3 (\log_2 x) &= 2 \\ \Rightarrow \log_2 x &= 3^2 = 9 \\ \Rightarrow x &= 2^9 = 512 \end{aligned}$$

12. Ans. (c)

$$\log_2 10 = \frac{1}{\log_{10} 2} = \frac{1}{.3010} = 3.3222$$

13. Ans. (c)

$$\begin{aligned} \log_{10} 5 &= \log_{10} \left(\frac{10}{2} \right) = \log_{10} 10 - \log_{10} 2 \\ &= 1 - \log_{10} 2 = (1 - 0.3010) = 0.6990. \end{aligned}$$

14. Ans. (d)

$$\begin{aligned} &\log_9 27 + \log_8 32 \\ &\log_{3^2} 3^3 + \log_{2^3} 2^5 \\ &\frac{3}{2} \log_3 3 + \frac{5}{3} \log_2 2 \\ \text{So, } &\frac{3}{2} + \frac{5}{3} = \frac{19}{6} \end{aligned}$$

15. Ans. (c)

Remember that $a^{\log_a x} = x$.

$$\begin{aligned} \therefore 16^{\log_4 5} &= (4^2)^{\log_4 5} = 4^{2 \log_4 5} \\ &= 4^{\log(5^2)} = 4^{\log_4(25)} = 25. \end{aligned}$$

16. Ans. (c)

$$\log_5(x^2 + x) - \log_5(x + 1) = 2$$

$$\Rightarrow \log_5 \left(\frac{x^2 + x}{x + 1} \right) = 2$$

$$\therefore \log_5 \left[\frac{x(x + 1)}{x + 1} \right] = 2$$

$$\text{or } \log_5 x = 2 \text{ or } x = 5^2 = 25.$$

17. Ans. (d)

$$\log x + \log y = \log(x + y)$$

$$\Rightarrow \log(x + y) = \log(xy)$$

$$\therefore x + y = xy \text{ or } x = y(x - 1)$$

$$\Rightarrow y = \frac{x}{x - 1}$$

18. Ans. (d)

Given Expression

$$= \log_x \left(\frac{p}{q} \right) + \log_x \left(\frac{q}{r} \right) + \log_x \left(\frac{r}{p} \right)$$

$$\log_x \left(\frac{p}{q} \times \frac{q}{r} \times \frac{r}{p} \right) = \log 1 = 0.$$

19. Ans. (a)

$$\log 4.5 = \log \left(\frac{9}{2} \right) = \log 9 - \log 2$$

$$= \log(3^2) - \log 2 = 2 \log 3 - \log 2$$

$$= (2 \times 0.4771 - 0.3010) = 0.6532.$$

□□□□





Progression

The chapter on progression is very interesting as it depicts real life problem in mathematical manner. Lots of question on this topics are asked in competitive Examination.

Questions in Public Sector, Banking and various Management Entrance Exam mostly appear from either Arithmetic progression or from Geometric progression.

Arithmetic Progression (AP)

Quantities are said to be in AP when they increase or decrease by a common difference.

For Example:

1. All natural numbers are in AP with common difference 1.

1, 2, 3, 4, 5

2. All Even & odd numbers are in AP having common difference 2.

Even numbers = 2, 4, 6, 8,

Odd numbers = 1, 3, 5, 7,

3. 3, 8, 13, 18

Arithmetic Progression can be represented as

$a, a+b, a+2d, a+3d$

Where a is the first term and

d is the common difference of series given.

n^{th} term of series = $a + (n - 1) d$

Sum of the given number of a series in AP

let a be the first term, d be the common difference, and n the total number of term then

$$\text{Sum of series } S = \frac{n}{2} [2a + (n-1)d]$$

also if L be the last term then

$$L = a + (n-1)d \text{ then}$$

$$S = \frac{n(a+L)}{2}$$

To find arithmetic mean between any two given quantities

Arithmetic mean between two numbers a and b can be calculated by

$$AM = \frac{a+b}{2}$$



Solved Examples

1. Find the arithmetic mean between 3 & 13

$$\text{Sol.: } AM = \frac{a+b}{2}$$

$$= \frac{3+13}{2} = 8 \text{ Ans.}$$

2. Find the 10th term of given series

3, 8, 13, 18

$$\text{Sol.: here } a = 3, d = 8 - 3 = 5$$

Now 10th term will be given by
 $a + (n-1)d$
 $= 3 + (10-1)5 = 48$ Ans.

3. Find 15th term of series

-8 -5 -2 1 4

Sol.: here $a = -8, d = 3$

So 15th term will be $-8 + 3(15-1) = 34$ Ans.

4. Find the sum of 20 term of given series

3, 10, 17, 24

Sol.: Sum of n term S is given by

$$S = \frac{n}{2}[2a + (n-1)d]$$

Here $a = 3, d = 7, n = 20$

$$\text{So, } S = \frac{20}{2}[2 \times 3 + (20-1) \times 7] = 1390 \text{ Ans.}$$

5. Calculate sum of 50 first positive even numbers.

Sol.: Even number = 2, 4, 6, 8,

here $a = 2, d = 2, n = 50$ So,

$$S = \frac{50}{2}[2 \times 2 + (50-1) \times 2] = 2550 \text{ Ans.}$$

To insert a given number of Arithmetic mean between two given Quantities

Let a and b be numbers then to insert n AM between a and b we have to calculate common difference between them common difference,

$$d = \frac{b-a}{n+1}$$

Now n arithmetic mean can be calculated as

$$a + \frac{b-a}{n+1}, a + \frac{2(b-a)}{n+1}, \dots, a + \frac{n(b-a)}{n+1}$$

For Example:

6. Insert 4 arithmetic means between 17 & 42

$$\text{Sol.: Common difference } d = \frac{b-a}{n+1}$$

$$= \frac{42-17}{4+1} = 5$$

Now four arithmetic means between 17 and 42 will be
 22, 27, 32, 37 Ans.

Geometric Progression (GP)

Quantities are said to be in GP when they increase or decrease by a constant factor.

The constant factor is called common ratio.

3, 6, 12, 24,

2, 6, 18, 54,

5, 5², 5³, 5⁴, etc are in GP

Geometric Progression can be represented as

a, ar, ar², ar³

where a is the first term and r is the common ratio.

nth term of a GP = arⁿ⁻¹

Sum of n term of a GP

$$S_n = \frac{a(r^n - 1)}{r - 1} \text{ [when } r > 1]$$

$$S_n = \frac{a(1 - r^n)}{(1 - r)} \text{ [when } r < 1]$$

Geometric mean (GM) between two numbers

GM between two numbers a and b can be calculated by

$$GM = \sqrt{ab}$$

7. What is common ratio of given series

-3, 1, $\frac{-1}{3}$, $\frac{1}{9}$,

$$\text{Sol.: Common ratio} = \frac{1}{-3} \text{ Ans.}$$

8. Find 6th term of given series 3, 12, 48,

Sol.: here $a = 3, r = 4$

$$\text{So 6th term can be given by } a \times r^{(n-1)} \\ = 3 \times 4^5 = 3072 \text{ Ans.}$$

9. Find sum of 10 term of given series

2, 4, 8, 16

$$\text{Sol.: } S = \frac{a(r^n - 1)}{(r - 1)} \quad [\text{when } r > 1]$$

$$S = \frac{2 \times (2^{10} - 1)}{(2 - 1)} = 2046 \text{ Ans.}$$

10. Calculate sum of six term of given series

$1, \frac{1}{3}, \frac{1}{3^2}, \frac{1}{3^3}, \dots$

$$\text{Sol.: } S = \frac{a(1 - r^n)}{(1 - r)} \quad [\text{when } r < 1]$$

$$S = \frac{1[1 - (\frac{1}{3})^6]}{1 - \frac{1}{3}} = \frac{364}{243} \text{ Ans.}$$

Sum of Infinite term of a series

Sum of infinite term of a series can be calculated when common ratio is less than 1.

$$S_{\infty} = \frac{a}{1 - r} \quad [r < 1]$$

Otherwise S_{∞} will be equal to ∞ .

11. Find sum of infinite term of series

$\frac{1}{2}, \frac{1}{4}, \frac{1}{8}, \dots$

$$\text{Sol.: } S_{\infty} = \frac{a}{1 - r} \quad [\because r < 1] = \frac{\frac{1}{2}}{1 - \frac{1}{2}} = 1 \text{ Ans.}$$

12. Find sum of infinite term of given series

$1, \frac{1}{3}, \frac{1}{3^2}, \frac{1}{3^3}, \dots$

$$\text{Sol.: } S_{\infty} = \frac{a}{1 - r} \quad [\because r < 1] = \frac{1}{1 - \frac{1}{3}} = \frac{3}{2} \text{ Ans.}$$

Harmonic Progression

If a, b, c, d are in Arithmetic progression then

$\frac{1}{a}, \frac{1}{b}, \frac{1}{c}, \frac{1}{d}$ are in Harmonic Progression

Harmonic mean HM of a and b

$$HM = \frac{2ab}{a + b}$$

13. Find next 3 terms of given series

$\frac{1}{3}, \frac{1}{8}, \frac{1}{13}, \dots$

Sol.: Here term are in HP because 3, 8, 13 are in AP.

Now next 3 term in AP are 18, 23, 28 so next

3 terms in HP are $\frac{1}{18}, \frac{1}{23}, \frac{1}{28}$ now series

become $\frac{1}{3}, \frac{1}{18}, \frac{1}{13}, \frac{1}{18}, \frac{1}{23}, \frac{1}{28}$ Ans.

14. Find harmonic mean between 40 & 60.

$$\text{Sol.: } HM = \frac{2ab}{a + b}$$

$$HM = \frac{2 \times 40 \times 60}{40 + 60} = 48 \text{ Ans.}$$

Useful Result

1. Sum of n natural numbers

$$S = 1 + 2 + 3 + 4 + \dots + n$$

$$S = \frac{n(n + 1)}{2}$$

2. Sum of squares of first n natural numbers

$$S = 1^2 + 2^2 + 3^2 + \dots + n^2$$

$$S = \left\{ \frac{n(n + 1)(2n + 1)}{6} \right\}$$

3. Sum of cubes of first
- n
- natural numbers

$$S = 1^3 + 2^3 + 3^3 + 4^3 + \dots + n^3$$

$$S = \left\{ \frac{n(n+1)}{2} \right\}^2$$

4. Sum of first
- n
- odd natural numbers

$$S = 1 + 3 + 5 + \dots + (2n-1)$$

$$S = n^2$$

5. Sum of first
- n
- even natural numbers

$$S = 2 + 4 + 6 + \dots + 2n$$

$$= n(n+1) = n^2 + n$$



Progression



Practice Exercise: I

- How many terms there in the AP 20, 25, 30, 130.

(a) 22	(b) 23
(c) 21	(d) 24
- Find the 1st term of an AP whose 8th and 12th terms are respectively 39 and 59.

(a) 5	(b) 6
(c) 4	(d) 3
- There is an AP 1, 3, 5 Which term of this AP is 55?

(a) 27th	(b) 26th
(c) 25th	(d) 28th
- Find the lowest number in an AP such that the sum of all the terms is 105 and greatest term is 6 times the least.

(a) 5	(b) 10
(c) 15	(d) 20
- Find the 15th term of the sequence 20, 15, 10,

(a) -45	(b) -55
(c) -50	(d) 0
- A sum of money kept in a bank amounts to Rs. 1240 in 4 years and Rs. 1600 in 10 years at simple Interst. Find sum.

(a) Rs. 800	(b) Rs. 900
(c) Rs. 1150	(d) Rs. 1000
- A number 15 is divided into three parts which are in AP and the sum of their squares is 83. Find the smallest number.

(a) 5	(b) 3
(c) 6	(d) 8
- The sum of the first 16 terms of an AP whose first term and third are 5 and 15 respectively is

(a) 600	(b) 765
(c) 640	(d) 680
- How many terms are there in the GP 5, 20, 80, 20480?

(a) 6	(b) 5
(c) 7	(d) 8
- A boy agrees to work at the rate of one rupee on the first day, two rupees on the second day, four rupees on the third day and so on. How much will the boy get if he starts working on the 1st of February and finishes on the 20th of February?

(a) 2^{20}	(b) $2^{20} - 1$
(c) $2^{19} - 1$	(d) 2^{19}
- The seventh term of as GP is 8 times the fourth term. What will be the first term when it's fifth term is 48?

(a) 4	(b) 3
(c) 5	(d) 2
- The sum of three numbers on a GP is 14 and the sum of their squares is 84. Find the largest number.

(a) 8	(b) 6
(c) 4	(d) None of these
- How many natural numbers between 300 to 500 are multiples of 7?

(a) 29	(b) 28
(c) 27	(d) None of these

14. The 4th and 10th term of an GP are 1/3 and 243 respectively. Find the 2nd term.
 (a) 3 (b) 1
 (c) 1/27 (d) 1/9
15. The 7th and 21st terms of an AP are 6 and -22 respectively. Find the 26th term.
 (a) -34 (b) -32
 (c) -12 (d) -10
16. Find the number of terms of the series 1/81, -1/27, 1/9, -729.
 (a) 11 (b) 12
 (c) 10 (d) 13
17. 'a' and 'b' are two number whose AM is 25 and GM is 7. Which of the following may be value of 'a'?
 (a) 10 (b) 20
 (c) 49 (d) 25
18. Two number A and B are such that their GM is 20% lower than their AM. Find the ratio between the numbers.
 (a) 3 : 2 (b) 4 : 1
 (c) 2 : 1 (d) 3 : 1

Solutions

1. Ans. (b)
 In series 20, 25, 30, 130.
 $a = 20, d = 5$
 n^{th} term is 130
 $\Rightarrow 20 + (n - 1) 5 = 130$
 $\Rightarrow 5n = 115, n = 23$
2. Ans. (c)
 Here $a + 7d = 39$ (i)
 $a + 11d = 59$ (ii)
 So, $4d = 20$
 $d = 5$
 $a + (7 \times 5) = 39$
 So, $a = 4$

3. Ans. (d)
 A P is given 1, 3, 5,
 here $a = 1, d = 2$
 $a + (n - 1) d = 55$
 $1 + (n - 1) 2 = 55$
 $n = 28$

4. Ans. (a), (b) and (c)
 Here $a + (n - 1)d = 6a$
 or $(n - 1)d = 5a$
 also it is given that

$$\frac{n}{2}[2a + (n - 1)d] = 105$$

$$\text{also } n/2 [a + l] = 105$$

[where l is last term]

$$\text{Now } n/2[a + 6a] = 105$$

$$n/2 [7a] = 105$$

now we go by trial and error

$$\text{if } a = 5 \text{ then } l = 30$$

then $d = 5$ in this case all the condition will be satisfied

5. Ans. (c)
 AP 20, 15, 10
 here $a = 20$
 $d = -5$
 15^{th} term will be $a + 14d$ which is equal to
 $20 + -5 \times 14 = -50$

6. Ans. (d)
 This is case of simple interest, simple interest follows AP
 $a + 4d = 1240$ (i)
 $a + 10d = 1600$ (ii)
 from (I) and (II) we get
 $a = 1000$ and $d = 60$

7. Ans. (b)
 Let numbers are $a - d, a$ and $a + d$
 now it is given that
 sum = 15 & sum of there square is 83 i.e.
 $3a = 15$ (i)
 $(a - d)^2 + a^2 + (a + d)^2 = 83$ (ii)
 $3a^2 + 2d^2 = 83$

$$75 + 2d^2 = 83$$

$$2d^2 = 8$$

$$d^2 = 4, d = 2$$

So, least term is $a - d = 3$

8. Ans. (d)

$$a = 5, a + 2d = 15$$

$$\text{So } d = 5$$

now sum of 16 term will be

$$16/2 [10 + 15 \times 5] = 680$$

9. Ans. (c)

GP is given: 5, 20, 80, ... 20 480

here $a = 5$

$$r = 20/5 = 4$$

how 20480 = $a r^{n-1}$

$$5 \times 4^{n-1}$$

$$\Rightarrow 4096 = 4^{n-1}$$

$$n - 1 = 6$$

$$n = 7$$

10. Ans. (b)

This sequence is in GP 1, 2, 4, 8,

Now sum of first 20 term will be

$$\frac{a(r^n - 1)}{r - 1} = 2^{20} - 1$$

11. Ans. (b)

It is given that

$$ar^6 = 8 ar^3$$

$$r^3 = 8, \quad r = 2$$

$$\text{Now } ar^4 = 48$$

$$a \times 2^4 = 48, \quad a = 3$$

12. Ans. (a)

a, ar, ar^2

$$\text{now } a + ar + ar^2 = 14 \dots\dots\dots(i)$$

$$\text{also } a^2 + a^2r^2 + a^2r^4 = 84 \dots\dots\dots(ii)$$

only suitable combination is 2, 4, 8

So largest term is 8

13. Ans. (a)

Between 300 and 500 the first term divisible by 7 is 301 and last term divisible by 7 is 497

So, here $a = 301, d = 7$

$$L = a + (n - 1) d$$

$$497 = 301 + (n-1) \times 7$$

$$\Rightarrow 7n = 203$$

$$\Rightarrow n = 29$$

14. Ans. (c)

It is given that

$$ar^3 = 1/3 \dots\dots\dots(i)$$

$$ar^9 = 243 \dots\dots\dots(ii)$$

from (i) and (ii) we get

$$r^6 = 729$$

$$r = 3 \dots\dots\dots(iii)$$

from (i) and (ii) we get

$$a \times 3^3 = \frac{1}{3}, \quad a = \frac{1}{81}$$

second term will be $\frac{1}{27}$

15. Ans. (b)

It is given that

$$a + 6d = 6 \text{ and (I)}$$

$$a + 20d = -22$$

$$\Rightarrow 14d = -28, \quad d = -2,$$

$$\Rightarrow a = 18$$

26th term will be -32

16. Ans. (a)

It is given that

$$GP \text{ is } \frac{1}{81}, \frac{-1}{27}, \frac{7}{9}, \dots\dots\dots -729$$

$$\text{Here } a = \frac{1}{81}, \quad r = -3$$

$$\text{now } ar^{n-1} = 729$$

$$\frac{1}{81} \times (-3)^{n-1} = -729$$

$$(-3)^{n-1} = 3^{10}, n = 11$$

17. Ans. (c)

$$\frac{a+b}{2} = 25$$

$$a + b = 50$$

$$\text{also } \sqrt{ab} = 7$$

$$ab = 49$$

here $a = 1$ & $b = 49$ or vice versa

18. Ans. (b)

$$\frac{a+b}{2} = \text{AM}$$

$$\sqrt{ab} = \text{GM}$$

Here it is given that

GM = 20% less than AM, that is

$$\text{GM} = \frac{4}{5} \text{AM}$$

$$\Rightarrow \sqrt{ab} = \frac{4}{5} \times \frac{a+b}{2}$$

only possibility is $a = 1$ & $b = 4$

or $a = 4$, $b = 1$

So, ratio is 4 : 1

□□□□

Progression



Practice Exercise: II

1. Determine 25th term of an A.P. whose 9th term

is -6 and common difference is $\frac{5}{4}$.

- (a) 16 (b) 18
(c) 12 (d) 14

2. Which term of the A.P. 5, 13, 21, is 181?

- (a) 21st (b) 22nd
(c) 23rd (d) 24th

3. Find the n th term of the series

$$\frac{1}{n} + \frac{n+1}{n} + \frac{2n+1}{n} + \dots$$

(a) $\frac{3+n^2+n}{n}$ (b) $\frac{1+n^2-n}{n}$

(c) $\frac{2+n^2-n}{n}$ (d) None of these

4. Determine k so that $\frac{2}{3}$, k , and $\frac{5}{8}k$ are three consecutive terms of an A.P.

- (a) $16/33$ (b) $14/33$
(c) $12/33$ (d) $18/33$

5. If 7 times the 7th term of an A.P. is equal to 11 times its, 11th term, then the 18th term of the A.P. is

- (a) 1 (b) 2
(c) 0 (d) 3

6. If the p th, q th and r th terms of an A.P. are a , b , c , respectively, find the value of $a(q-r) + b(r-p) + c(p-q)$

- (a) 2 (b) 1
(c) 0 (d) 3

7. A ball rolling up an incline covers 36 metres during the first second, 32 metres during the second, 28 metres during the next and so on. How much distance will it travel during the 8th second?

- (a) 8 metres (b) 6 metres
(c) 7 metres (d) 9 metres

8. If the 5th and the 12th terms of an A.P. are 30 and 65, respectively, what is the sum of the first 20 terms?

- (a) 1175 (b) 1250
(c) 1150 (d) 1350

9. The sum of a series in A.P. is 525. Its first term is 3 and last term is 39. Find the common difference.

- (a) $3/2$ (b) $3/3$
(c) $2/3$ (d) $1/3$

10. The sum of p terms of an A.P. is $3p^2 + 4p$.
Find the n^{th} term?
(a) $5n + 2$ (b) $6n + 1$
(c) $8n + 3$ (d) $7n + 3$
11. Find the sum of all integer between 50 and 500 which are divisible by 7.
(a) 17966 (b) 1177996
(c) 17766 (d) 17696
12. Which term of the gemoetric sequence $\frac{1}{3}, \frac{1}{9}, \frac{1}{27}, \dots$ is $\frac{1}{19683}$?
(a) 9 (b) 7
(c) 11 (d) 13
13. The 5th term of a G.P. is 2, find the product of first 9 terms.
(a) 508 (b) 512
(c) 504 (d) 516
14. The 3rd term of a G.P. is the square of the first term. If the second term is 8, determine the 6th term.
(a) 136 (b) 132
(c) 128 (d) 124
15. For what value of x , the number $\frac{-2}{7}, x, -\frac{7}{2}$ are in G.P.?
(a) 1, -2 (b) 1, -3
(c) 1, -5 (d) 1, -1
16. The sum of first three terms of a G.P. is to the sum of first six terms is 125 : 152. Find the common ration of G.P.
(a) $\frac{2}{5}$ (b) $\frac{4}{5}$
(c) $\frac{3}{5}$ (d) $\frac{1}{5}$
17. Evaluate $\sum_{j=1}^{11} (2+3^j)$
- (a) $22 + \frac{3}{2}(3^{11} - 1)$ (b) $11 + \frac{3}{2}(3^{11} - 1)$
(c) $22 + \frac{33}{22}(3^{10} - 1)$ (d) None of these
18. The common ration of a G.P. is $-\frac{4}{5}$ and the sum to infinity is $\frac{80}{9}$. Find the first term.
(a) 14 (b) 16
(c) 14 (d) 10
19. Sum the series to infinity
 $\frac{3}{4} - \frac{5}{4^2} + \frac{3}{4^3} - \frac{5}{4^4} + \frac{3}{4^5} - \frac{5}{4^6} + \dots$
(a) $\frac{8}{15}$ (b) $\frac{7}{17}$
(c) $\frac{7}{15}$ (d) $\frac{8}{17}$
20. Find the 9th term of the H.P. 6, 4, 3,
(a) $\frac{7}{5}$ (b) $\frac{6}{5}$
(c) $\frac{5}{6}$ (d) None of these
21. If $x > 1, y > 1, z > 1$ are in G.P., then $\frac{1}{1+\log x}, \frac{1}{1+\log y}, \frac{1}{1+\log z}$ are in
(a) A.P. (b) H.P.
(c) G.P. (d) None of these
22. If a be the first term of a G.P., l the n^{th} term and P the product of first n terms then $P =$
(a) $a l^{n/2}$ (b) $(a - l)^{n/2}$
(c) $(a + l)^{n/2}$ (d) None of these

Solutions

1. Ans. (d)
Let a be the first term and d the common difference of an A.P.

Then, $a_n = a + (n - 1) d$

$$a_9 = a + (9 - 1) \left(\frac{5}{4} \right)$$

$$\Rightarrow a_9 = a + 10$$

$$\Rightarrow -6 = a + 10$$

$$\Rightarrow a = -6 - 10 = -16$$

$$\therefore a_{25} = -16 + (25 - 1) \frac{5}{4}$$

$$= -16 + 30 = 14$$

2. Ans. (c)

Here, first term $a = 5$

Common difference $d = 8$

Let 181 be the n th term. i.e. $a_n = 181$.

$$\therefore 181 = 5 + (n - 1)8 \text{ or, } 176 = (n - 1)8$$

$$\therefore n - 1 = 176 \div 8 = 22$$

$$\therefore n = 23$$

Hence, 181 is the 23rd term.

3. Ans. (b)

$$\text{Here } a = \frac{1}{n}, d = \frac{n+1}{n} - \frac{1}{n} = 1$$

$$\therefore a_n = a + (n - 1) d$$

$$\therefore a_n = \frac{1}{n} + (n - 1)(1) = \frac{1}{n} + n - 1 = \frac{1 + n^2 - n}{n}$$

4. Ans. (a)

$$\therefore \frac{2}{3}, k, \frac{5}{8} k \text{ are in A.P.}$$

$$\therefore k - \frac{2}{3} = \frac{5}{8} k - k \Rightarrow \frac{5k}{8} - 2k = \frac{-2}{3}$$

$$\Rightarrow \frac{-11k}{8} = \frac{-2}{3} \Rightarrow k = \frac{16}{33}$$

5. Ans. (c)

Let a be the first and d , the common difference of an A.P.

$$\therefore a_7 = a + 6d$$

$$a_{11} = a + 10d \therefore 7a_7 = 11a_{11}$$

$$7(a + 6d) = 11(a + 10d)$$

$$\Rightarrow 7a + 42d = 11a + 110d$$

$$\Rightarrow 4a + 68d = 0$$

$$\Rightarrow a + 17d = 0$$

$$\Rightarrow a_{18} = 0$$

6. Ans. (c)

Let A be the first term and D , the common difference of A.P.

$$a_p = a, \therefore A + (p - 1) D = a \dots(i)$$

$$a_q = b, \therefore A + (q - 1) D = b \dots(ii)$$

$$a_r = c, \therefore A + (r - 1) D = c \dots(iii)$$

$$\begin{aligned} \therefore a(q - r) + b(r - p) + c(p - q) \\ &= [A + (p - 1) D] (q - r) + [A + (q - 1) D] (r - p) \\ &\quad + [A + (r - 1) D] (p - q) \\ &= (q - r + r - p + p - q) A + [(p - 1)(q - r) \\ &\quad + (q - 1)(r - p) + (r - 1)(p - q)] D \\ &= 0 \cdot A + 0 \cdot D = 0 \end{aligned}$$

7. Ans. (a)

Distance covered during the 1st second = 36 m

Distance covered during the 2nd second = 32 m

Distance covered during the 3rd second = 28 m.

The distance covered form an A.P.

$$= 36 + 32 + 28 \dots \text{ in which}$$

$$a = 36, d = -4$$

\therefore Distance covered in 8th second

= 8th term of the A.P.

$$= a + 7d = 36 + 7(-4)$$

$$= 36 - 28 = 8 \text{ metres.}$$

8. Ans. (c)

Let a be the first term and d the common difference of an AP., then

$$a_5 = a + 4d = 30 \dots(i)$$

$$a_{12} = a + 11d = 65 \dots(ii)$$

Subtracting (i) from (ii), we get

$$7d = 35 \Rightarrow d = 5$$

∴ From (i)

$$a + 4(5) = 30$$

$$\Rightarrow a = 30 - 20 = 10$$

$$\text{Now, } S_n = \frac{n}{2}[2a + (n-1)d]$$

$$\therefore S_{20} = \frac{20}{2}[2 \times 10 + (20-1)5]$$

$$= 10[20 + 95] = 1150.$$

9. Ans. (a)

If n be the number of terms, then

$$a_n = a + (n-1)d,$$

where a is the first term and d the common difference.

$$\therefore 39 = 3 + (n-1)d.$$

$$\text{Also } S_n = \frac{n}{2}[a_1 + a_n]$$

$$\therefore 525 = \frac{n}{2}[3 + 39] \Rightarrow 1050 = n(42)$$

$$\text{or, } n = \frac{1050}{42} = 25$$

putting $n = 25$ in (i), we get

$$(25-1)d = 36 \Rightarrow d = 36 \div 24 = \frac{3}{2} = 1\frac{1}{2}$$

10. Ans. (b)

$$\text{Here, } S_p = 3p^2 + 4p$$

Putting $p = n$, we have

$$S_n = 3n^2 + 4n$$

Changing n to $(n-1)$, we get

$$\begin{aligned} S_{n-1} &= 3(n-1)^2 + 4(n-1) \\ &= 3(n^2 - 2n + 1) + 4n - 4 \\ &= 3n^2 - 2n - 1 \end{aligned}$$

$$\begin{aligned} \therefore a_n &= S_n - S_{n-1} \\ &= 3n^2 + 4n - 3n^2 + 2n + 1 = 6n + 1. \end{aligned}$$

11. Ans. (d)

The first integer, after 50 which is divisible by

7 is 56 and the last integer before 500 which is divisible by 7 is 497.

∴ The sequence of integers between 50 and 500 which are divisible by 7 is

$$56, 63, 70, \dots, 497$$

It is an A.P. with

$$a = 56, d = 7$$

$$a_n = 497 = a + (n-1)d$$

$$\therefore 497 = 56 + (n-1) \times 7$$

$$\therefore 7n = 497 + 7 - 56$$

$$\text{or, } 7n = 448$$

$$\text{or, } n = 488 \div 7 = 64$$

$$\text{Required sum} = \frac{n}{2}(a_1 + a_n)$$

$$= \frac{64}{2}(56 + 497) = 32 \times (553) = 17696.$$

12. Ans. (a)

Let n^{th} term of the given sequence be $\frac{1}{19683}$.

Then,

$$a_n = ar^{n-1} \Rightarrow \frac{1}{19683} = \frac{1}{3} \left(\frac{1}{3} \right)^{n-1}$$

$$\Rightarrow \left(\frac{1}{3} \right)^8 = \left(\frac{1}{3} \right)^{n-1}$$

$$\Rightarrow n-1 = 8 \Rightarrow n = 9.$$

13. Ans. (b)

Let a be the first term and r the common ratio

$$\therefore a_5 = 2 \Rightarrow ar^4 = 2 \quad \dots(i)$$

Now, product of first 9 terms

$$\begin{aligned} &= a \times ar \times ar^2 \times \dots \times ar^8 \\ &= a^9 r^{1+2+\dots+8} = a^9 r^{36} \\ &= (ar^4)^9 = 2^9 = 512. \end{aligned}$$

14. Ans. (c)

Let a be the first term and r be the common ratio of G.P.

$$\text{We have } a_3 = (a_1)^2 \Rightarrow ar^2 = a^2$$

$$\Rightarrow r^2 = a \quad \dots(i)$$

Also, $a_2 = 8$
 $\Rightarrow ar = 8 \dots(ii)$

Multiplying (i) and (ii) we get
 $ar^3 = 8 \times a \therefore r^3 = 8 \Rightarrow r = 2$

From (i) $a = (2)^2 = 4$
 Hence, $a_6 = ar^5 = (4)(2)^5 = 4 \times 32 = 128$.

15. Ans. (d)

$\frac{-2}{7}, x, \frac{-7}{2}$ are in G.P.

$$\Rightarrow \frac{x}{-2/7} = \frac{-7/2}{x} \Rightarrow x^2 = \frac{-7}{2} \times \frac{-2}{7}$$

$$\therefore x^2 = 1 \Rightarrow x = \pm 1.$$

16. Ans. (c)

$$\text{Here, } \frac{S_3}{S_6} = \frac{125}{152} \cdot \frac{a(r^3-1)/(r-1)}{a(r^6-1)/(r-1)} = \frac{125}{152}$$

$$\Rightarrow \frac{r^3-1}{r^6-1} = \frac{125}{152} \therefore \frac{r^3-1}{(r^3-1)(r^3+1)} = \frac{125}{152}$$

$$\Rightarrow \frac{1}{r^3+1} = \frac{125}{152} \therefore 152 = 125r^3 + 125$$

$$\Rightarrow 125r^3 = 27 \Rightarrow r^3 = \frac{27}{125}$$

$$\text{or, } r^3 = \left(\frac{3}{5}\right)^3 \therefore r = \frac{3}{5}$$

Hence, the common ratio of G. P. is $\frac{3}{5}$.

17. Ans. (a)

$$\begin{aligned} & (2+3^1) + (2+3^2) + (2+3^3) + \dots + (2+3^{11}) \\ & = 2 + 2 + 2 + \dots \text{ up to 11 terms} \\ & + (3 + 3^2 + 3^3 + \dots \text{ up to 11 terms}) \\ & = 11 \times 2 + \frac{3(3^{11}-1)}{3-1} = 22 + \frac{3}{2}(3^{11}-1) \end{aligned}$$

18. Ans. (b)

$$S_\infty = \frac{a}{1-r} \Rightarrow \frac{80}{9} = \frac{a}{1-\left(\frac{-4}{5}\right)} \Rightarrow \frac{80}{9} = \frac{a}{9/5}$$

$$\Rightarrow a = \frac{80}{9} \times \frac{9}{5} = 16$$

Hence, the first term is 16.

19. Ans. (c)

$$\left(\frac{3}{4} + \frac{3}{4^3} + \frac{3}{4^5} + \dots \text{to } \infty\right)$$

$$-\left(\frac{5}{4^2} + \frac{5}{4^4} + \frac{5}{4^6} + \dots \text{to } \infty\right)$$

$$= \frac{3/4}{1-\left(\frac{1}{4}\right)^2} - \frac{5/4^2}{1-\left(\frac{1}{4}\right)^2}$$

$$= \frac{3}{4} \times \frac{16}{15} - \frac{5}{16} \times \frac{16}{15} = \frac{4}{5} - \frac{1}{3}$$

$$= \frac{12-5}{15} = \frac{7}{15}$$

20. Ans. (b)

The given sequence is 6, 4, 3, which is H..P.

The sequence of reciprocals of its terms is

$$\frac{1}{6}, \frac{1}{4}, \frac{1}{3}, \dots \text{ which is an A., P}$$

$$\text{Here, } a = \frac{1}{6}, d = \frac{1}{4} - \frac{1}{6} = \frac{1}{12}$$

$$\therefore a_9 \text{ of A.P.} = a + 8d$$

$$= \frac{1}{6} + 8 \times \frac{1}{12} = \frac{1}{6} + \frac{4}{6} = \frac{5}{6}$$

$$\therefore 9\text{th term of H.P. is } \frac{6}{5}$$

21. Ans. (b)

$\therefore x, y, z$ are in G.P.

$$\therefore y^2 = xz$$

Taking log on both sides

$$2 \log y = \log x + \log z$$

$$\Rightarrow 2 + 2 \log y = (1 + \log x) + (1 + \log z)$$

$$\Rightarrow 2(1 + \log y) = (1 + \log x) + (1 + \log z)$$

$$\Rightarrow 1 + \log x, 1 + \log y, 1 + \log z, \text{ are in A.P.}$$

$$\Rightarrow \frac{1}{1+\log x}, \frac{1}{1+\log y}, \frac{1}{1+\log z} \text{ are in H.P.}$$

22. Ans. (a)

If r is the common ratio of G.P., then

$$l = a r^{n-1} \quad \dots(i)$$

The first n terms of the G.P. are

$$a, ar, ar^2, ar^3, \dots, ar^{n-1}$$

$$P = a \times ar \times ar^2 \times \dots \times ar^{n-1}$$

$$= a^n \times r^{1+2+3+\dots+(n-1)}$$

$$= a^n \times r^{\frac{(n-1) \times n}{2}} = (a^2)^{n/2} \times (r^{n-1})^{n/2}$$

$$= (a^2 r^{n-1})^{n/2} = (a \cdot ar^{n-1})^{n/2} = (al)^{n/2}$$

□□□□

Progression



Practice Exercise: III

- If the sum of the 6th and the 15th elements of an arithmetic progression is equal to the sum of the 7th, 10th and 12th elements of the same progression, then which element of the series should necessarily be equal to zero?
 - 10th
 - 8th
 - 1st
 - None of these
- What is the eighth term of the sequence 1, 4, 9, 16, 25, ?
 - 8
 - 64
 - 128
 - 200
- If p, q, r, s are in harmonic progression and $p > s$, then
 - $\frac{1}{ps} < \frac{1}{qr}$
 - $q + r = p + s$
 - $\frac{1}{q} + \frac{1}{r} = \frac{1}{p} + \frac{1}{s}$
 - None of these
- If $\log_x a, a^{x/2}$ and $\log_b x$ are in GP, then x is
 - $\log_a(\log_b a)$
 - $\log_a(\log_e a) + \log_a(\log_e b)$
 - $-\log_a(\log_a b)$
 - $\log_a(\log_e b) - \log_a(\log_e a)$
- A person pays Rs. 975 in monthly installments, each monthly installment being less than the former by Rs. 5. The amount of the first installment is Rs. 100. In what time, will the entire amount be paid?
 - 12 months
 - 26 months
 - 15 months
 - 18 months
- Let S_n denote the sum of the first 'n' terms of an A.P. $S_{2n} = 3S_n$. Then, the ratio S_{3n}/S_n is equal to
 - 4
 - 6
 - 8
 - 10
- Three numbers are in G.P. Their sum is 28 and their product is 512. The numbers are
 - 6, 9 and 13
 - 4, 8 and 16
 - 2, 8 and 18
 - 2, 6 and 18
- The sum of the series:

$$1^2 + 2^2 + 3^2 + 4^2 + \dots + 15^2$$
 is
 - 1080
 - 1240
 - 1460
 - 1620
- If $\frac{1}{b} - \frac{1}{c} = \frac{1}{a} - \frac{1}{b}$, then a, b, c form a/an
 - Arithmetic progression
 - Geometric Progression
 - Harmonic Progression
 - None of these
- In G. P., the first term is 5 and the common ratio is 2. The eighth term is
 - 640
 - 1280
 - 256
 - 160

11. If the arithmetic mean of two numbers is 5 and geometric mean is 4, then the number are

- (a) 4, 6 (b) 4, 7
(c) 3, 8 (d) 2, 8

12. The value of

$$(1^3 + 2^3 + 3^3 + \dots + 15^3) - (1 + 2 + 3 + \dots + 15)$$

- (a) 14280 (b) 14400
(c) 12280 (d) 13280

13. The mean of the cubes of the first n natural numbers is

- (a) $\frac{n(n+1)^2}{4}$ (b) n^2
(c) $\frac{n(n+1)(n+2)}{8}$ (d) $(n^2 + n + 1)$

14. If $\frac{3+5+7+\dots+n \text{ terms}}{5+8+11+\dots+10 \text{ terms}} = 7$, then the value of n is

- (a) 35 (b) 36
(c) 37 (d) 40

15. If the sum of first n natural numbers is one-fifth of the sum of their squares, then n is

- (a) 5 (b) 6
(c) 7 (d) 8

16. What is the least value of n such that $(1 + 3 + 3^2 + \dots + 3^n)$ exceeds 2000?

- (a) 7 (b) 5
(c) 8 (d) 6

17. The sum of 12 terms of an A.P., whose first term is 4, is 252. What is the last term?

- (a) 35 (b) 36
(c) 37 (d) 38

18. If $\log 2$, $\log(2^x - 1)$ and $\log(2^x + 3)$ (all to the base 10) be three consecutive terms of an Arithmetic Progression, then the value of x is equal to

- (a) 0 (b) 1
(c) $\log_2 5$ (d) $\log_{10} 2$

19. The third term of a Geometric Progression is

4. The product of the first five terms is

- (a) 4^3 (b) 4^5
(c) 4^4 (d) None of these

Solutions

1. Ans. (b)

Let a be the first term and d be the common ratio of an A.P.

$$\begin{aligned} \therefore (a+5d) + (a+14d) \\ &= (a+6d) + (a+9d) + (a+11d) \\ \Rightarrow a+7d &= 0 \\ \Rightarrow 8\text{th term} &= 0. \end{aligned}$$

2. Ans. (b)

$$8^2 = 64.$$

3. Ans. (c)

p, q, r, s are in harmonical progression

$$\Rightarrow \frac{1}{p}, \frac{1}{q}, \frac{1}{r}, \frac{1}{s} \text{ are in A.P.}$$

$$\Rightarrow \frac{1}{q} - \frac{1}{p} = \frac{1}{s} - \frac{1}{r}$$

$$\Rightarrow \frac{1}{q} + \frac{1}{r} = \frac{1}{p} + \frac{1}{s}$$

4. Ans. (a), (c)

Given statement

$$\Rightarrow (a^{x/2})^2 = (\log_b x) \times (\log_x a)$$

$$= a^x = \log_b a$$

$$\Rightarrow x \log_a = \log_a [\log_b a]$$

$$\Rightarrow x = \log_a [\log_b a].$$

5. Ans. (c)

Let n be the number of months in which all the installments can be paid

First Installment = Rs. 100

Common Difference = -5

⇒ Sum of the series with n terms whose first term is 100 or common difference is (-5) = 975

$$\text{i.e. } \frac{n}{2}[2a + (n-1)d] = 975$$

$$\text{i.e. } \frac{n}{2}[2 \times 100 + (n-1)(-5)] = 975$$

$$\text{i.e. } n^2 - 41n + 390 = 0$$

$$\text{i.e. } n = 26 \text{ or } n = 15$$

For $n=15$, total amount paid

$$= \frac{15}{2}[2 \times 100 + (15-1)(-5)]$$

$$= \frac{15}{2}[200 - 70] = 975.$$

6. Ans.(b)

$$S_n = \frac{n}{2}[a + (n-1)d]$$

[where a is the first term and d is the common difference]

$$S_{2n} = \frac{2n}{2}[a + (2n-1)d]$$

$$S_{3n} = \frac{3n}{2}[a + (3n-1)d]$$

$$\text{Given, } S_{2n} = 3S_n$$

$$\Rightarrow n[a + 2nd - d] = 3 \left[\frac{n}{2}(a + nd - d) \right]$$

$$\Rightarrow d = \frac{a}{1+n}$$

$$\therefore \frac{S_{3n}}{S_n} = \frac{\frac{3n}{2}[a + 3nd - d]}{\frac{n}{2}[a + nd - d]}$$

$$= \frac{3 \left[a + \frac{3na}{1+n} - \frac{a}{1+n} \right]}{a + \frac{na}{1+n} - \frac{a}{1+n}} = 6.$$

7. Ans. (b)

Let the three numbers be a, ar, ar^2 , where r is common ratio.

$$\therefore a + ar + ar^2 = 28 \text{ and } a^3 r^3 = 512$$

$$\therefore ar = 8 \Rightarrow a + ar^2 = 20$$

$$\Rightarrow 8r^2 - 20r + 8 = 0$$

$$\Rightarrow r = 2, r = \frac{1}{2}$$

if $r = 2$, $a = 4$. Therefore, the three numbers are 4, 8, 16

8. Ans. (b)

The sum of the squares of the first n natural numbers is

$$\frac{n(n+1)(2n+1)}{6}$$

Put $n = 15$, we have, $1^2 + 2^2 + 3^2 + 4^2 + \dots + 15^2$

$$= \frac{15(15+1)(30+1)}{6} = 1240.$$

9. Ans. (c)

$$\frac{2}{b} = \frac{1}{a} + \frac{1}{c}$$

$$\Rightarrow b = \frac{2ac}{a+c} \Rightarrow \frac{1}{a}, \frac{1}{b}, \frac{1}{c} \text{ are in A.P.}$$

⇒ a, b, c are in H.P.

10. Ans. (a)

n^{th} term of a G.P. = ar^{n-1}

where a = first term and r is the common ratio.

$$\therefore 8^{\text{th}} \text{ term} = 5 \times (2)^7 = 5 \times 128 = 640.$$

11. Ans. (d)

Let x, y be the numbers

$$\therefore \frac{x+y}{2} = 5 \text{ and } \sqrt{xy} = 4 \Rightarrow xy = 16$$

$$\therefore x + y = 10, xy = 16$$

$$\Rightarrow (x-y)^2 = (x+y)^2 - 4xy = 100 - 64 = 36$$

$$\Rightarrow x - y = 6 \quad \therefore x = 8, y = 2.$$

12. Ans. (a)

Given expression

$$= \left[\frac{15 \times 16}{2} \right]^2 - \frac{15 \times 16}{2} = (120)^2 - 120$$

$$= 120 \times 119 = 14280.$$

13. Ans. (a)

Sum of the cubes of first n natural numbers

$$= \left[\frac{n(n+1)}{2} \right]^2 = \frac{n^2(n+1)^2}{4}$$

$$\therefore \text{Mean} = \frac{n(n+1)^2}{4}$$

14. Ans. (a)

S_n = Sum of n terms of an A.P.

$$= \frac{n}{2} [2a + (n-1)d]$$

where a = first term,

d = common difference

$$\therefore \frac{3+5+7+\dots+n \text{ terms}}{5+8+11+\dots+10 \text{ terms}} = 7$$

$$\Rightarrow \frac{\frac{n}{2} [2 \times 3 + (n-1) \times 2]}{\frac{10}{2} [2 \times 5 + (10-1) \times 3]} = 7$$

$$\Rightarrow \frac{n(2n+4)}{370} = 7$$

$$\Rightarrow 2n^2 + 4n - 2590 = 0$$

$$\Rightarrow n^2 + 2n - 1295 = 0$$

$$\Rightarrow n^2 + 37n - 35n - 1295 = 0$$

$$\Rightarrow n(n+37) - 35(n+37) = 0$$

$$\Rightarrow (n-35)(n+37) = 0$$

$$\Rightarrow n = 35.$$

15. Ans. (c)

$$\text{Sum of the first } n \text{ natural numbers} = \frac{n(n+1)}{2}$$

Sum of the squares of the first n natural numbers

$$= \frac{n(n+1)(2n+1)}{6}$$

$$\therefore \frac{n(n+1)}{2} = \frac{1}{5} \left(\frac{n(n+1)(2n+1)}{6} \right)$$

$$\Rightarrow 2n+1 = 15 \Rightarrow n = 7.$$

16. Ans. (c)

$$\frac{3^n - 1}{3 - 1} > 2000 \Rightarrow 3^n > 4001 \Rightarrow n = 8.$$

17. Ans. (d)

$$S_n = \frac{n}{2} [\text{First term} + \text{Last term}]$$

Where $a = 4, n = 12, L = ?$

$$\therefore S_{12} = 256 = \frac{12}{2} [4 + L]$$

$$\Rightarrow 4 + L = 42$$

$$\Rightarrow L = 38$$

18. Ans. (c)

$\log 2, \log(2^x - 1),$

$\log(2^x + 3)$ are in A.P.

$$\Rightarrow 2[\log(2^x - 1)] = \log 2 + \log(2^x + 3)$$

$$= \log [2 \times (2^x + 3)]$$

$$\Rightarrow \log(2^x - 1)^2 = \log[2^{x+1} + 6]$$

$$\Rightarrow (2^x - 1)^2 = 2^{x+1} + 6 = 2^x \cdot 2 + 6$$

$$\text{Let } 2^x = y$$

$$\therefore (y - 1)^2 = 2y + 6 \Rightarrow y^2 - 2y + 1 = 2y + 6$$

$$\Rightarrow y^2 - 4y - 5 = 0$$

$$\Rightarrow (y - 5)(y + 1) = 0$$

$$\Rightarrow y = 5, -1$$

$$\text{If } y = 5 \Rightarrow 2^x = 5 \Rightarrow x \log 2 = \log 5$$

$$\Rightarrow x = \frac{\log 5}{\log 2} \Rightarrow x = \log_2 5.$$

19. Ans.(b)

Let a be the first term of a G. P. and r be the common ratio

\therefore First five terms of a G.P. are a, ar, ar^2, ar^3, ar^4 .

\therefore Third term = $ar^2 = 4 \Rightarrow (ar^2)^5 = 4^5$.

□□□□



Permutation & Combination

In real life situations we come across various problems of selections and arrangements. For example selection of Indian cricket team, and then deciding their batting order. Similarly formation of a group of 5-6 members out of 40 students in a class for college tech festival and deciding their order of arrangement for their stage performance etc. All these problems are very interesting and comes under the topic permutations and combinations.

Permutation

Permutation is defined as arrangement of object in an ordered manner.

For example, let there are 3 chairs for 3 persons A, B and C then sitting arrangement can be made in $3!$ ways like

ABC
ACB
BAC
BCA
CAB
CBA

Permutation is represented by nPr here nPr is total number of ways in which r things at a time can be selected and arranged at a time from among n things.

$$nPr = \frac{n!}{(n-r)!}$$

For example, If we have to make a sitting arrange for 5 students and if only three chairs are available, then this can be done in $5P_3$ i.e.

$$5P_3 = \frac{5!}{(5-3)!} = 60 \text{ way}$$

THEORY

1. Factorial notion $n!$
 $n! = n(n-1)(n-2) \dots \dots \dots 3.2.1$ product of all n consecutive integer from n to 1
2. $0! = 1$
3. $1! = 1$
4. $(n-1)! = (n-1)(n-2)(n-3) \dots \dots \dots 3.2.1$
5. $n! = n \cdot (n-1)!$
6. only the factorial of natural numbers are defined.
 $n!$ is defined for only $n > 0$
 $n!$ is not defined for $n < 0$

Combination

Combination is defined as selection of objects in which order does not matter. For example let a team of 2 players is to be formed out of 3 players A, B and C. Then this can be done in three ways AB, BC and CA. Here order of AB is not important

whether B comes first or second. AB is similar to BA because we are selecting two players A and B. Now, if one player is captain and other is vice captain then this can be done in 6 ways.

Captain	Vice Captain
A	B
B	A
B	C
C	B
C	A
A	C

In all these 6 cases we are selecting two players and arranging them into order manner in which there is one captain and one vice captain. So, this is a case of arrangement and called permutation.

Combination is represented by nC_r ,

$$nC_r = \frac{n!}{(n-r)! \times r!}$$

Here nC_r can be defined as number of ways of selection of r things at a time from among n things.

Example: Selection of 5 person from among 10 can be done by $10C_5$ way

$$\text{which is equal to } \frac{10!}{5! \times 5!} = 252$$

Permutation is a special case of selection and arrangement

$$\text{We know that } nP_r = \frac{n!}{(n-r)!} \text{ and also}$$

$$nC_r = \frac{n!}{(n-r)! \times r!}$$

$$\text{So, } nP_r = nC_r \times r!$$

$$= nC_r \times rP_r$$

Thus, in words it can be defined as

The permutation or arrangement of r things out of n is nothing but the selection of r things out of n things following by the arrangement of r selected things amongst themselves.

For example a sitting arrangement for 5 players from among 11 players of Indian cricket team can be done by first selecting 5 from among 11 players & then arranging them in different order.

$$11P_5 = 11C_5 \times 5P_5$$

$$= (\text{Selection \& then arrangement})$$

Binomial Theorem

According to binomial theorem

$$nC_0 + nC_1 + nC_2 + \dots + nC_n = 2^n$$

This is a very powerful theorem having wider application in various sets of problems.

It is nothing but total number of selection of zero or more things out of n different things =

$$nC_0 + nC_1 + nC_2 + \dots + nC_n = 2^n$$

For Example: Rahul has 5 friends, he wants to invite them into a New Year Party. He can invite either

- (1) No one into a party. i.e. $5C_0 = 1$
- (2) One into a party, i.e. $5C_1 = 5$
- (3) Two into a party, i.e. $5C_2 = 10$
- (4) Three into a party i.e. $5C_3 = 10$
- (5) Four into a party i.e. $5C_4 = 5$
- (6) All 5 into the party i.e. $5C_5 = 1$

So total number of ways comes out is 32 which is equal to 2^5 according to Binomial Theorem.

Important Results with Explanation

1. Number of permutation of n different things taken all at a time = $n!$
2. Number of permutation of n things out of which p are of one type, q are alike of second type and r are alike of third type and rest all different

$$= \frac{n!}{p!q!r!}$$

Example: Out of 20 balls, if 10 are red in colour, 6 are blue in colour and 4 are green in colour. Now these balls can be arranged in linear fashion in $\frac{20!}{10! \times 6! \times 4!}$ number of ways.

3. Number of permutation of n different things taken r at a time when repetition is allowed

$$= n \times n \times n \times \dots \dots \dots r \text{ times} = n^r$$

Example: How many three digit number can be formed by 1, 3 and 5 if repetition is allowed.
Solution: This can be done $3^3 = 27$ ways.

4. Number of selection of r things out of n identical things = 1

Example: In how many ways 3 balls pens can be chosen out of 50 identical balls pens.
Solution: Since, all the 50 ball pens are identical then number of ways to select 3 balls pens = 1.

5. Selection of r things out of n things if k things are always selected = $(n-k)C_{(r-k)}$

Example: If out of 11 football players 6 are to be invited into a party such that Captain & Goalkeeper will always be invited, then this can be done in $(11-2)C_{6-2} = 9C_4$ ways.

6. Selection of r things out of n things if k things are never be selected = $(n-k)C_r$

Example: If out of 11 football players 6 are to be invited into a party such that Captain and Goal Keeper will never be invited, then this can be done in $(11-2)C_6 = 9C_6$ ways

7. $nC_r = nC_{n-r}$

8. Number of selection of k consecutive things out of n things in a row
 = $n - k + 1$ ways

9. Number of squares in a square of n x n

$$\text{side} = 1^2 + 2^2 + 3^2 \dots n^2$$

Number of rectangles in a square of

$$n \times n \text{ sides} = 1^3 + 2^3 + 3^3 \dots n^3$$

Thus the number of squares and rectangles in the following figures are given by

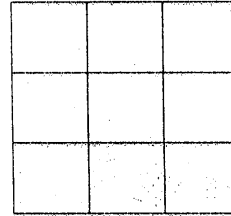

Number of square

$$= 1^2 + 2^2 + 3^2 = 14 = \sum_1^n n^2$$

Number of rectangles

$$= 1^3 + 2^3 + 3^3 = 36 = \sum_1^n n^3$$

Circular Permutation

In case of circular permutation the total number of ways of arrangement is $(n-1)!$

For example: Sitting arrangements for 6 people around a dining table in 6 chairs will be $(6-1)! = 120$ ways

Flowers in a garland and beads in a neckless can

be arranged in $\frac{(n-1)!}{2}$ ways. Here clockwise and

anticlock-wise observations are not different.





Solved Examples

1. Find the number of ways of arrangement of 10 person in four chairs?

$$\text{Solution: } 10P_4 = \frac{10!}{6!} = 5040$$

2. How many 2 digit numbers can be formed out of digit 2, 4, 6, 8 when repetition is not allowed?

Solution: This can be done in $4P_2$ ways ie 12 number can be formed.

3. In the above question how many numbers can be formed when repetition is allowed?

Solution: We have to form two digit number i.e., we have to fill two place @@ out of 4 numbers & any number can be used any number of times this can be done in $4 \times 4 = 16$ ways.

4. How many words can be formed by using letters of word MADAM?

Solution: In MADAM we have

2 – M's

2 – A's

So total number of ways of forming words are

$$\frac{5!}{2! \times 2!} = 30$$

5. Of the different words that can be formed from letters of word MOBILE, how many begins with M and ends with E?

Solution: $\boxed{M} \square \square \square \square \boxed{E}$

M and E are fixed at the start and end positions, Hence, we have to arrange B, I, L, O among themselves (ie in four places), this can be done in $4!$ ways.

6. Six boys and 4 girls wanted to enjoy a movie. How many ways of sitting arrangement can be possible for them if girls want to sit together?

Solution: $B_1 B_2 B_3 B_4 B_5 B_6, G_1 G_2 G_3 G_4 \dots (1)$

Now if all girls are sitting together then

$B_1 B_2 B_3 B_4 B_5 B_6 X \dots (2)$

(here X is symbolic notation that all girls are sitting together)

equation (2) Can be arranged in $7!$ ways

Now girls can be arranged among themselves i.e., $4!$ ways so total number of sitting arrangement will be $7! \times 4!$ ways

7. In the above question find number of ways of arrangement if no two girls sit together.

Solution: This can be done in following manner – $B_1 - B_2 - B_3 - B_4 - B_5 - B_6 -$

First of all, boys can be arranged in $6!$ ways, now vacant seats between them will be filled by girls. This can be done in $7P_4$ ways so total arrangement = $7P_4 \times 6!$

8. In the question number (6) find total arrangement if no two boys sit together.

Solution: first of all above we have to make arrangement for girls – $G_1 - G_2 - G_3 - G_4 -$ this can be done in $4!$ ways. Now, since only 5 places are available for boys, then definitely two boys will sit together. So this is impossible condition.

9. How many words can be formed from letters of ENGINEER?

Solution: Here Engineer contains

3 E's and 2 N's, one each G, I & R

So total number of words

$$= \frac{8!}{3! \times 2!} = 3360$$

10. How many 5 digit number can be formed by using 0, 1, 2, 3, 4, 5, 6, 7 only once?

Solution: $d_1 \ d_2 \ d_3 \ d_4 \ d_5$
 $\square \ \square \ \square \ \square \ \square$

box d_1 cannot be filled with zero so only 7 numbers can be filled in first box rest can be done in

$$7 \times 7 \times 6 \times 5 \times 4 = 5880 \text{ ways}$$

11. How many different sums can be formed with the following coins?

5 rupees, 1 rupee, 50 paisa, 25 paisa, 10 paisa, 1 paisa.

Solution: A distinct sum will be formed by selecting either 1 or 2 or 3 or 4 or 5 or all 6 coins.

$$6C_1 + 6C_2 + 6C_3 + 6C_4 + 6C_5 + 6C_6 \text{ ways.}$$

By binomial theorem this can be done in $2^6 - 1$ way.

Answer = 63.

12. Out of 15 points in a plane, no three are in straight line except 5 which are collinear. How many straight lines can be formed?

Solution: If all 15 points were non collinear then the answer would have been $15C_2$. However, in this case, $15C_2$ has double counting since the 5 collinear points are also among the 15. These would have been counted as $5C_2$ whereas they should have been counted as 1. Thus to remove the double counting and get the correct answer, we need to adjust by reducing the count by $(5C_2 - 1)$.

$$\text{Hence, the answer } 15C_2 - (5C_2 - 1) = 96$$

13. How many triangle can be formed by 18 points if all are non collinear.

Solution: To form a triangle we have to connect any three points. i.e., in this case select any three points out of 18. This can be done in $18C_3$ ways = 816

14. In the above situation how many triangle can be formed if 5 points are collinear.

Solution: The triangles will be given by

$$18C_3 - 5C_3 = 806 \text{ ways}$$

$\square \square \square \square$

Permutation & Combination



Practice Exercise: I

- How many number of 3 digits can be formed with the digits 1, 2, 3, 4, 5 (repetition of digits not allowed)?
 (a) 125 (b) 120
 (c) 60 (d) 150
- How many numbers between 2000 and 3000 can be formed with the digits 0, 1, 2, 3, 4, 5, 6, 7 (repetition of digits not allowed)?
 (a) 42 (b) 210
 (c) 336 (d) 440
- In how many ways can a person send invitation cards to 6 of his friends if he has four servants to distribute the cards?
 (a) 6^4 (b) 4^6
 (c) 24 (d) None of these
- In how many ways can 7 Indians, 5 Pakistanis and 6 Dutch be seated in a row so that all persons of the same nationality sit together?
 (a) $3!$ (b) $7!5!6!$
 (c) $3!7!5!6!$ (d) $18!$
- How many straight lines can be formed from 8 non-collinear points on the X-Y plane?
 (a) 28 (b) 56
 (c) 18 (d) 19860
- If ${}^nC_3 = {}^nC_8$ then find n.
 (a) 11 (b) 12
 (c) 14 (d) 10

7. In how many ways can the letters of the word PATNA be rearranged?
 (a) 60 (b) 120
 (c) 119 (d) 59
8. In the above question, how many words would be there which would start with the letter P?
 (a) 24 (b) 12
 (c) 60 (d) 18
9. How many numbers of four digits can be formed with the digits, 0, 1, 2, 3 (repetition of digits being allowed)?
 (a) 12 (b) 108
 (c) 256 (d) 192
10. A captain and a vice-captain are to be chosen out of a team having 11 players. How many ways are there to achieve this?
 (a) 10×9 (b) ${}^{11}C_2$
 (c) 110 (d) 109!
11. In how many ways can Ram choose a vowel and a consonant from the letter ALLAHABAD?
 (a) 4 (b) 6
 (c) 9 (d) 5
12. There are three rooms in a motel : one single, one double and one for four persons. How many ways are there to house seven persons in these rooms?
 (a) $7! / 1! 2! 4!$ (b) $7!$
 (c) $7! / 3$ (d) $7! / 3!$
13. How many new words are possible from the letters of the word PERMUTATION?
 (a) $11!/2!$ (b) $(11!/2!)-1$
 (c) $11!-1$ (d) none of these
14. In how many ways can the letters of the word EQUATION be arranged so that all the vowels come together?
 (a) ${}^9C_4 \cdot {}^9C_5$ (b) $4! \cdot 5!$
 (c) $9! / 5!$ (d) $9! - 4!5!$
15. A man has 3 shirts, 4 trousers and 6 ties. What are the number of ways in which he can dress himself with a combination of all the three?
 (a) 13 (b) 72
 (c) $13! / 3! \cdot 4! \cdot 6!$ (d) $3! \cdot 4! \cdot 6!$
- Direction for questions 16-17 : There are 25 points on a plane of which 7 are collinear. Now solve the following :
16. How many straight lines can be formed?
 (a) 7 (b) 300
 (c) 280 (d) none of these
17. How many triangles can be formed from these points?
 (a) 453 (b) 2265
 (c) 755 (d) none of these
18. How many batting order s are possible for the Indian cricket team if there is a squad of 15 to choose from such that Sachin Tendulkar is always chosen?
 (a) $1001 \cdot 11!$ (b) $364 \cdot 11!$
 (c) $11!$ (d) $15 \cdot 11!$
19. How many distinct words can be formed out of the word PROWLING that start with R and end with W?
 (a) $8!/2!$ (b) $6!2!$
 (c) $6!$ (d) none of these
20. How many 7-digit numbers are there having the digit 3 three times and the digit 0 four times?
 (a) 15 (b) $3^3 \times 4^4$
 (c) 30 (d) none of these

Solutions

1. Ans. (c)
 Three digits can be formed in $5P_3$ ways that is $\frac{5!}{(5-3)!} = 60$

2. Ans. (b)

Number between 2000 and 3000 are four digit numbers in which 2 is the first digit

$$\begin{array}{cccc} d_1 & d_2 & d_3 & d_4 \\ \boxed{2} & \boxed{} & \boxed{} & \boxed{} \end{array}$$

So, 2 must be taken in box d_1

Now rest box can be filled in

$7P_3$ ways

$$\Rightarrow \frac{7!}{(7-3)!} = 210 \text{ ways}$$

3. Ans. (b)

Person has six invitation cards 1 card can be given to any of 4 servants so six cards can be distributed in

$$4 \times 4 \times 4 \times 4 \times 4 \times 4 = 4^6 \text{ ways}$$

4. Ans. (c)

We have

→ 7 Indian

→ 5 Pakistanis and

→ 6 Dutch

7 Indias can sit in $7!$ ways

5 Pakistanis can sit in $5!$ ways

6 Dutch can sit in $6!$ ways

Also they can sit together in $3!$ different ways $7! \times 5! \times 6! \times 3!$

5. Ans. (a)

To draw a line we have to choose two points

So, $8C_2 = 28$ ways

6. Ans. (a)

$${}^n C_r = {}^n C_{(n-r)}$$

$$r + (n-r) = n$$

$$\text{So, } 3 + 8 = n = 11$$

7. Ans. (a)

This can be done in $\frac{5!}{2!}$ ways

$$\frac{5!}{2!} = 60$$

8. Ans. (b)

In PATNA P is fixed so we have only four letter ATNA in which there are two A's.

$$\text{So, } \frac{4!}{2!} = 12$$

9. Ans. (d)

$$\begin{array}{cccc} d_1 & d_2 & d_3 & d_4 \\ \boxed{} & \boxed{} & \boxed{} & \boxed{} \end{array}$$

We have given four digits.

'0' cannot be placed in box d_1

So total digits $3 \times 4 \times 4 \times 4 \Rightarrow 192$ Ways.

10. Ans. (c)

$11C_2 \times 2!$ Ways which is equal to 110

11. Ans. (a)

In Allahabad we have 4 A's that is only one vowel & 4 consonants (B, D, H, L)

So any four combination

AB, AD, AH, AL are only 4 possibilities so

12. Ans. (a)

This can be done in $\frac{7!}{1! \times 2! \times 4!}$ ways

13. Ans. (b)

In PERMUTATION we have 2T's, and one each P, E, R, M, U, A, I, O, N so total new

words formed will be $\frac{11!}{2!} - 1$ ways

{Note here PERMUTATION is not counted}

14. Ans. (b)

In EQUATION there are five Vowels A, E, I, O and U and three consonants N, Q, T so the possible arrangements will be $4! \times 5!$ ways

15. Ans. (b)

We have

Item:	Shirts	Trousers	Ties
Number	3	4	6

So total number of dressing will be

$$3 \times 4 \times 6 = 72 \text{ ways}$$

16. Ans. (c)

Total number of straight lines

$$= 25C_2 - 7C_2 + 1 = 280$$

17. Ans. (b)

Total triangle formed will be equal to

$$25C_3 - 7C_3 = 2265$$

18. Ans. (a)

$${}^{15-1}C_{11-1} \times 11!$$

$$\Rightarrow 14C_{10} \times 11! = 1001 \times 11!$$

19. Ans. (c)

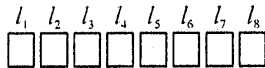

l_1 is R & l_8 is W rest boxes can be filled in $6!$ ways

20. Ans. (a)

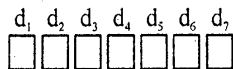

d_1 is 3 because we have to form 7 digit number now we have rest six boxes $d_2, d_3, d_4, d_5, d_6, d_7$ to be filled, this can be done in

$$\frac{6!}{2! \times 4!} = 15 \text{ ways}$$



Permutation & Combination



Practice Exercise: II

- There are 6 candidates for 3 posts. In how many ways can the posts be filled?

(a) 120 (b) 130
(c) 100 (d) 110
- There are 15 buses running between Delhi & Mumbai. In how many ways can a man go to Mumbai and return by a different bus?

(a) 280 (b) 310
(c) 240 (d) 210
- A teacher of a class wants to set one question from each of two exercises in a book. If there are 15 and 12 questions in the two exercises respectively, then in how many ways can the two questions be selected?

(a) 160 (b) 140
(c) 180 (d) 120
- A code word is to consist of two English alphabets followed by two distinct numbers between 1 and 9. For example, CA23 is a code word. How many such code words are there?

(a) 615800 (b) 46800
(c) 719500 (d) 410800
- There are 5 letters and 5 directed envelopes. Find the number of ways in which the letters can be put into the envelopes so that all are not put in directed envelopes?

(a) 129 (b) 119
(c) 109 (d) 139
- How many different numbers of two digits can be formed with the digits 1, 2, 3, 4, 5, 6; no digits being repeated?

(a) 40 (b) 30
(c) 35 (d) 45
- How many three-digit odd numbers can be formed from the digits 1, 2, 3, 4, 5, 6 when

(i) repetition of digits is not allowed
(ii) repetition of digits is allowed?

(a) (i) 60, (ii) 108 (b) (i) 50, (ii) 98
(c) (i) 70, (ii) 118 (d) (i) 80, (ii) 128
- How many odd numbers less than 1000 can be formed using the digits 0, 2, 5, 7? (repetition of digits is allowed).

(a) 52 (b) 32
(c) 22 (d) 42

9. How many numbers are there between 100 and 1000 in which all the digits are distinct?
 (a) 548 (b) 648
 (c) 748 (d) 756
10. How many integers between 1000 and 10000 have no digits other than 4, 5 or 6?
 (a) 91 (b) 51
 (c) 81 (d) 71
11. If $(n + 1)! = 6 [(n - 1)!]$, find n
 (a) 6 (b) 4
 (c) 8 (d) 2
12. How many words, with or without meaning, can be formed using all letters of the word EQUATION, using each letter exactly once?
 (a) 38320 (b) 39320
 (c) 40320 (d) 38400
13. Ten students are participating in a race. In how many ways can the first three prizes be won?
 (a) 920 (b) 680
 (c) 820 (d) 720
14. It is required to seat 5 men and 4 women in a row so that the women occupy the even places. How many such arrangements are possible?
 (a) 2880 (b) 2480
 (c) 3680 (d) 3280
15. Four books, one each in chemistry, Physics, Biology and Mathematics are to be arranged in a shelf. In how many ways can this be done?
 (a) 12 (b) 36
 (c) 24 (d) 48
16. How many different numbers of six digits can be formed with the numbers 3, 1, 7, 0, 9, 5?
 (a) 500 (b) 400
 (c) 400 (d) 600
17. How many three-digit numbers are there, with no digits repeated?
 (a) 648 (b) 548
 (c) 848 (d) 748
18. In how many different ways, the letters of the word ALGEBRA can be arranged in a row if
 (i) The two As are together?
 (ii) The two As are not together?
 (a) (i) 720, (ii) 1800
 (b) (i) 620, (ii) 1600
 (c) (i) 780, (ii) 1860
 (d) (i) 720, (ii) 1600
19. How many different words can be formed with the letters of the word 'BHARAT'?
 In how many of these B and H are never together?
 (a) 240, 180 (b) 360, 240
 (c) 320, 200 (d) 380, 260
20. How many different necklaces can be formed with 6 white and 5 red beads?
 (a) 18 (b) 24
 (c) 21 (d) 27
21. If $C(n, 7) = C(n, 5)$, find n
 (a) 15 (b) 12
 (c) 18 (d) 2
22. If $C(n, 8) = C(n, 6)$, find $C(n, 2)$
 (a) 91 (b) 81
 (c) 61 (d) 71
23. If ${}^{18}C_r = {}^{18}C_{r+2}$, find rC_5
 (a) 56 (b) 63
 (c) 49 (d) 42
24. Find $\sum_{r=1}^5 C(5, r)$
 (a) 41 (b) 31
 (c) 51 (d) 61
25. In how many ways can 5 sportmen be selected from a group of 10?
 (a) 272 (b) 282
 (c) 252 (d) 242

Solutions

1. **Ans. (a)**

The 1st post can be filled up in 6 ways. The 2nd post can be filled up in 5 ways. and the 3rd post can be filled up in 4 ways.

∴ By the principle of association, the three posts can be filled up in $6 \times 5 \times 4 = 120$ ways.

2. **Ans. (d)**

The first event of going from Delhi to Mumbai can be performed in 15 ways as he can go by any of the 15 buses. But the event of coming back from Mumbai can be performed in 14 ways (a different bus is to be taken).

Hence, both the events can be performed in $15 \times 14 = 210$ ways.

3. **Ans. (c)**

Since the first exercise contains 15 questions, the number of ways of choosing the first question is 15. Since the second exercise contains 12 questions, the number of ways of choosing the second question is 12. Hence, by the fundamental principle, two questions can be selected in $15 \times 12 = 180$ ways.

4. **Ans. (b)**

(i) There are in all 26 English alphabets. We have to choose 2 distinct alphabets:

First alphabet can be selected in 26 ways.

Second alphabet can be selected in 25 ways.

Again, out of 9 digits (1 to 9), first digit can be selected in 9 ways. Second digit can be selected in 8 ways.

Thus, the number of distinct codes

$$= 26 \times 25 \times 9 \times 8 = 46800$$

5. **Ans. (b)**

Here, the first letter can be put in any one of the 5 envelopes in 5 ways. Second letter can be put in any one of the 4 remaining envelopes in 4 ways. Continuing in this way, we get the total number of ways in which 5 letters can be put into 5 envelopes

$$= 5 \times 4 \times 3 \times 2 \times 1 = 120.$$

Since out of the 120 ways, there is only one way for putting each letter in the correct envelope. Hence, the number of ways of putting letters all not in directed envelopes = $120 - 1 = 119$ ways.

6. **Ans. (b)**

We have to fill up two places (since numbers are of two digits.)

The first place can be filled up in 6 ways, as any one of the six digits can be placed in the first place. The 2nd place can be filled up in 5 ways as no digit is to be repeated. Hence, both places can be filled up in $6 \times 5 = 30$ ways

7. **Ans. (a)**

(i) When repetition of digits is not allowed:

Since we have to form a three-digit odd number, thus the digit at unit's place must be odd. Hence, the unit's place can be filled up by 1, 3 or 5, that is, in 3 ways.

Now, the ten's digit can be filled up by any of the remaining 5 digits in 5 ways and then the hundred's place can be filled up by the remaining 4 digits in 4 ways.

Hence, the number of three-digit odd numbers that can be formed $3 \times 4 \times 5 = 60$

(ii) When repetition of digits is allowed:

Again, the unit's place can be filled up by 1, 3, 5, that is, in 3 ways. But the ten's and hundred's place can be filled up by any of the six given digits in 6 ways each. (Since repetition is allowed)

Hence, the number of three-digit odd numbers that can be formed = $3 \times 6 \times 6 = 108$.

8. **Ans. (b)**

Since required numbers are less than 1000, they are 1-digit, 2-digit or 3-digit numbers.

(i) Only 2 one-digit odd numbers are possible, namely 5 and 7.

(ii) For two-digit odd numbers, the unit's place can be filled up by 5 or 7 in 2 ways

and ten's place can be filled up by 2, 5 or 7 (not 0) in 3 ways.

$$\begin{aligned} \therefore \text{Possible 2-digit odd numbers} \\ = 2 \times 3 = 6 \end{aligned}$$

(iii) For three-digit odd numbers, the unit's place can be filled up by 5 or 7 in 2 ways. The ten's place can be filled up by any one of the given four digits in 4 ways. The hundred's place can be filled up by 2, 5 or 7 (not 0) in 3 ways.

$$\begin{aligned} \therefore \text{Possible 3-digit odd number} \\ = 2 \times 4 \times 3 = 24 \\ \therefore \text{Required number of numbers} \\ = 2 + 6 + 24 = 32 \end{aligned}$$

9. Ans. (b)

Any number between 100 and 1000 is of three digits. Since the numbers should have distinct digits, repetition of digits 0, 1, 2, 3, 4, 5, 6, 7, 8, 9 is not allowed.

Also 0 cannot be placed on the extreme left place. Hundredth place can be filled in 9 ways. Tenth place can be filled in 9 ways. Unit's place can be filled in 8 ways.

$$\begin{aligned} \therefore \text{The total three-digit numbers} \\ = 9 \times 9 \times 8 = 648 \end{aligned}$$

10. Ans. (c)

Any number between 1000 and 10000 is of 4 digits. The unit's place can be filled up by 4 or 5 or 6, that is, in 3 ways.

Similarly, the ten's place can be filled up by 4 or 5 or 6, that is, in 3 ways. The hundred's place can be filled up by 4 or 5 or 6, that is, in 3 ways and the thousand's place can be filled up by 4 or 5 or 6, i.e. in 3 ways.

$$\begin{aligned} \text{Hence, the required number of numbers} \\ = 3 \times 3 \times 3 \times 3 = 81 \end{aligned}$$

11. Ans. (d)

$$(n+1)! = 6[(n-1)!]$$

$$\Rightarrow (n+1) \cdot n \cdot [(n-1)!] = 6[(n-1)!]$$

$$\Rightarrow n^2 + n = 6 \Rightarrow n^2 + n - 6 = 0$$

$$\Rightarrow (n-2)(n+3) = 0$$

$$\therefore \text{Either } n-2=0 \text{ or } n+3=0$$

$$\Rightarrow n=2 \text{ or } n=-3$$

n being natural number, so $n \neq -3$, $\therefore n=2$.

12. Ans. (c)

The word EQUATION has exactly 8 letters which are all different.

\therefore Number of words that can be formed = number of permutations of 8 letters taken all at a time.

$$\begin{aligned} &= P(8, 8) = 8! \\ &= 8 \times 7 \times 6 \times 5 \times 4 \times 3 \times 2 \times 1 \\ &= 40320 \end{aligned}$$

13. Ans. (d)

Out of 10 students, the first three prizes can be won in

$$\begin{aligned} {}^{10}P_3 &= \frac{10!}{(10-3)!} = \frac{10!}{7!} \\ &= 10 \times 9 \times 8 \\ &= 720 \text{ ways} \end{aligned}$$

14. Ans. (a)

$$\text{Total number of candidates} = 5 + 2 = 9$$

In the row of 9 positions, the even places are 2nd, 4th, 6th and 8th. Now, number of even places = 4. Number of women to occupy the even places = 4.

$$\begin{aligned} \therefore \text{Even places can be filled} &= P(4, 4) \text{ ways} \\ \text{Number of men} &= 5 \end{aligned}$$

$$\therefore \text{The remaining 5 places can be filled by 5 men} = P(5, 5) \text{ ways}$$

\therefore By the fundamental principle of counting.

\therefore The required number of seating arrangements

$$= P(4, 4) \times P(5, 5) = 4! \times 5!$$

$$= 24 \times 120 = 2880.$$

15. Ans. (c)

4 different books can be arranged among themselves, in a shelf, in $P(4, 4)$
 $= 4 \times 3 \times 2 \times 1 = 24$ ways.

16. Ans. (d)

The numbers that can be formed, by taking all six digits together.

$$= {}^6 P_6 = 6!$$

But we have to neglect the numbers which begin with zero. Now the numbers in which zero comes in the 1st Place = 5!
 Hence, the required number = $6! - 5!$
 $= 720 - 120 = 600.$

17. Ans. (a)

The required number of three-digit numbers = The permutations of the 10 objects 0, 1, 2, 3, 4, 5, 6, 7, 8, 9 take 3 at a time, with the condition that 0 is not in the hundred's place.

$$= P(10, 3) - P(9, 2)$$

$$= \frac{10!}{7!} - \frac{9!}{7!}$$

$$= \frac{10 \times 9 \times 8 \times 7!}{7!} - \frac{9 \times 8 \times 7!}{7!}$$

$$= 10 \times 9 \times 8 - 9 \times 8$$

$$= 720 - 72 = 648$$

18. Ans. (a)

ALGEBRA has seven letters where 2-A, 1-L, 1-G, 1-E, 1-B and 1-R.

(i) Since two A's are always together, we take both the A's as one letter.

If p is the number of arrangements, then
 $p = 6! = 6 \times 5 \times 4 \times 3 \times 2 \times 1 = 720.$

(ii) Total number of permutations

$$q = \frac{7!}{2!} = 7 \times \frac{7 \times 6 \times 5 \times 4 \times 3 \times 2 \times 1}{2 \times 1}$$

$$= 2520$$

In these permutations, in some permutations, two A's are together while in the rest they are not together.

Hence, the number of permutations in which two A's are not together in

$$q - p = 2520 - 720 = 1800.$$

19. Ans. (b)

Out of letters in the word 'BHARAT' two letters, that is, A's are alike.

$$\therefore \text{Number of permutations} = \frac{6!}{2!} = 360.$$

Number of words in which B and H are never together.

= Total number of words - number of words in which B and H are together

$$= 360 - \frac{5!}{2!} = 360 - 120 = 240.$$

20. Ans. (c)

n = total no. of beads = 6 + 5 = 11

$$P_1 = 6, P_2 = 5$$

\therefore No. of different necklaces

$$= \frac{1(11-1)!}{2 \cdot 6! \cdot 5!} = \frac{10!}{2 \cdot 6! \cdot 5!}$$

$$= \frac{10 \cdot 9 \cdot 8 \cdot 7 \cdot 6!}{2 \cdot 6! \cdot 5 \cdot 4 \cdot 3 \cdot 2 \cdot 1} = 3 \times 7 = 21.$$

21. Ans. (b)

We know ${}^n C_r = {}^n C_{n-r}$

$$\Rightarrow (n-r) + r = n$$

$$\Rightarrow \text{Given } C(n, 7) = C(n, 5)$$

$$\Rightarrow {}^n C_7 = {}^n C_5$$

$$\Rightarrow 7 + 5 = n$$

$$\therefore n = 12$$

22. Ans. (a)

$$C(n, 8) = C(n, 6)$$

$$\Rightarrow {}^n C_8 = {}^n C_6$$

$$\Rightarrow n = 8 + 6$$

$$\therefore n = 14$$

$$C(n, 2) = ?$$

$${}^n C_2 = {}^{14} C_2 = \frac{14 \times 13}{1 \times 2} = 91$$

23. Ans. (a)

$${}^{18} C_r = {}^{18} C_{18-r} \quad [\because {}^n C_r = {}^n C_{n-r}]$$

$$\text{But } {}^{18} C_r = {}^{18} C_{r+2} \quad [\text{Given}]$$

$$\therefore {}^{18} C_{18-r} = {}^{18} C_{r+2}$$

$$\text{or, } 18 - r = r + 2 \Rightarrow r = 8.$$

$$\therefore {}^r C_5 = {}^8 C_5 = \frac{8!}{5!3!}$$

$$= \frac{8 \times 7 \times 6 \times 5!}{3 \times 2 \times 1 \times 5!} = 56.$$

24. Ans. (b)

$$\sum_{r=1}^5 C(5, r) = C(5, 1) + C(5, 2) +$$

$$C(5, 3) + C(5, 4) + C(5, 5)$$

$$\left[\begin{array}{l} \text{From Binomial theorem} \\ {}^n C_0 + {}^n C_1 + {}^n C_2 + \dots + {}^n C_n = 2^n \end{array} \right]$$

$${}^5 C_1 + {}^5 C_2 + \dots + {}^5 C_5 = 2^5 - {}^5 C_0$$

$$= 32 - 1 = 21$$

25. Ans. (c)

The require number of ways = $C(10, 5)$

$$= \frac{10!}{5!5!} = \frac{10 \cdot 9 \cdot 8 \cdot 7 \cdot 6}{5 \cdot 4 \cdot 3 \cdot 2} = 3 \cdot 2 \cdot 4 \cdot 2 = 252.$$

□□□□

Permutations & Combinations



Practice Exercise: III

- The letters of word PROMISE are arranged so that no two of the vowels should come together. Find the total number of arrangements.
(a) 49 (b) 1440
(c) 7 (d) 1898
- In an examination paper there are two groups, each containing 4 questions. A candidate is required to attempt 5 questions but not more than 3 questions from any group. In how many ways can 5 questions be selected?
(a) 24 (b) 48
(c) 96 (d) None of these
- A box contains 10 balls out of which 3 are red and the rest are blue. In how many ways can a random sample of 6 balls be drawn from the bag so that at the most 2 red balls are included in the sample and no sample has all the 6 balls of the same colour?
(a) 105 (b) 168
(c) 189 (d) 120
- A cricket team of 11 players is to be formed from 20 players including 6 bowlers and 3 wicket keepers. The number of ways in which a team can be formed having exactly 4 bowlers and 2 wicket keepers is
(a) 20790 (b) 6930
(c) 10790 (d) 360
- In a hockey championship, there were 153 matches played. Every two teams played one match with each other. The number of teams participating in the championship is
(a) 18 (b) 19
(c) 17 (d) 16

6. Seven points lie on a circle. How many chords can be drawn by joining these points.
 (a) 22 (b) 21
 (c) 23 (d) 24
7. Ten different letters of an alphabet are given. Words with 5 letters are formed from these given letters. Then the number of words which have at least one letter repeated is
 (a) 69760 (b) 30240
 (c) 99748 (d) None of these
8. The value of ${}^{10}C_4 + {}^{10}C_5$ is
 (a) 462 (b) 466
 (c) 469 (d) 465
9. Five persons A, B, C, D and E occupy seats in a row such that A and B sit next to each other. In how many possible ways can these five people sit?
 (a) 24 (b) 48
 (c) 72 (d) None of these
10. The number of zeros at the end of $60!$ is
 (a) 12 (b) 14
 (c) 16 (d) 18
11. A department had 8 male and female employees each. A project team involving 3 male and 3 female members needs to be chosen from the department employees. How many different project teams can be chosen?
 (a) 112896 (b) 3136
 (c) 720 (d) 112
12. From a group of 7 men and 6 women 5 people are to be selected to form a committee so that at least 3 men are there on the committee. In how many ways can it be done?
 (a) 756 (b) 735
 (c) 564 (d) 645
13. In how many different ways can the letters of the word TRAINER be arranged so that the vowels always come together?
 (a) 1440 (b) 120
 (c) 720 (d) 360
14. A polygon has 44 diagonals, then the number of its side are
 (a) 11 (b) 9
 (c) 7 (d) 5
15. A five digit number divisible by 3 is to be formed using the numerals 0, 1, 2, 3, 4 and 5 without repetition. The total number of ways in which this can be done is
 (a) 211 (b) 216
 (c) 221 (d) 311
16. How many parallelograms will be formed if 7 parallel horizontal lines intersect 6 parallel vertical lines?
 (a) 42 (b) 294
 (c) 315 (d) None of these
17. Which of the following is equal to $\frac{1.3.5\dots(2n-1)}{2.4.6\dots(2n)}$?
 (a) $(2n)! + (2^n(n!))^2$ (b) $(2n)! + n!$
 (c) $(2n-1) + (n-1)!$ (d) 2^n
 (e) None of these
18. A dean must select three students to serve on a committee. If she is considering five students, then from how many different possible threesomes must she choose?
 (a) 2 (b) 3
 (c) 10 (d) 15
19. Out of 10 red and 8 white balls, 5 red and 4 white balls can be drawn in how many ways?
 (a) ${}^8C_5 \times {}^{10}C_4$ (b) ${}^{18}C_9$
 (c) ${}^{10}C_5 \times {}^8C_4$ (d) None of these

Solutions

1. Ans. (b)

The four constants can be written in $4!$ ways i.e. 24 ways. The three vowels can be written in $3!$ ways, i.e. 6 ways. Since no two vowels can come together, therefore vowels can be inserted in any three places out of the five places available, such as, V P V R V M V S V , i.e. in 5C_3 ways, i.e. 10 ways. Total number of arrangements required
 $= 24 \times 6 \times 10 = 1440$

2. Ans. (b)

$${}^4C_3 \times {}^4C_2 + {}^4C_2 \times {}^4C_3 = 4 \times 6 + 4 \times 6 = 48.$$

3. Ans. (b)

The possible ways are as follows:

(i) 1 red ball out of the three and 5 blue balls out the seven.

(ii) 2 red balls out of the three and 4 blue balls out of the seven

\therefore Total number of ways in which a random sample of six balls can be drawn.

$${}^3C_1 \times {}^7C_5 + {}^3C_2 \times {}^7C_4 = 168$$

4. Ans. (a)

There are 6 bowlers, 3 wicket keepers and 11 batsman in all. The number of ways in which a team of 4 bowlers, 2 wicket keepers and 5 batsman can be chosen.

$$= {}^6C_4 \times {}^3C_2 \times {}^{11}C_5$$

$$= {}^6C_2 \times {}^3C_1 \times {}^{11}C_5$$

$$= \frac{6 \times 5}{2 \times 1} \times \frac{3}{1} \times \frac{11 \times 10 \times 9 \times 8 \times 7}{5 \times 4 \times 3 \times 2 \times 1} = 20790.$$

5. Ans. (a)

$$= {}^{18}C_2 = \frac{18 \times 17}{2} = 153.$$

6. Ans. (b)

$$= {}^7C_2 = \frac{7!}{2!5!} = \frac{7 \times 6 \times 5!}{5! \times 2!} = 21.$$

7. Ans. (a)

$$10^5 - {}^{10}P_5 = 69760$$

8. Ans. (a)

$$= {}^{10}C_4 + {}^{10}C_5 = {}^{11}C_5 = 462.$$

9. Ans. (b)

$$4! \times 2 \text{ ways, i.e. } 24 \times 2 = 48.$$

10. Ans. (a)

11. Ans. (b)

$$= {}^8C_3 \times {}^8C_3 = \frac{8 \times 7 \times 6}{3 \times 2} \times \frac{8 \times 7 \times 6}{3 \times 2}$$

$$= 56 \times 56 = 3136.$$

12. Ans. (a)

$${}^7C_3 \times {}^6C_2 + {}^7C_4 \times {}^6C_1 + {}^7C_5 \times {}^6C_0$$

$$= {}^7C_3 \times {}^6C_2 + {}^7C_3 \times 6 + {}^7C_2 \times 1$$

$$= \frac{7 \times 6 \times 5}{3 \times 2 \times 1} \times \frac{6 \times 5}{2 \times 1} + \frac{7 \times 6 \times 5}{3 \times 2 \times 1} \times 6 + \frac{7 \times 6}{2 \times 1}$$

$$= 525 + 210 + 21 = 756.$$

13. Ans. (d)

Treating (AIE), i.e. all the vowels together as one letter. Therefore, the word capital, i.e.

TRNR (AIE) can be arranged in $\frac{5!}{2}$ ways.

(\because R is repeated).

Since (AIE) can also be arranged in $3!$ ways, therefore, required number of ways

$$= \frac{5!}{2} \times 3! = \frac{120 \times 6}{2} = 360.$$

14. Ans. (a)

Let the number of sides be n .

$$\therefore {}^nC_2 - n = 44, n > 0 \Rightarrow \frac{n(n-1)}{2} - n = 44$$

$$\Rightarrow n^2 - 3n - 88 = 0$$

$$\Rightarrow n^2 - 11n + 8n - 88 = 0$$

$$\Rightarrow n(n-11) + 8(n-11) = 0$$

$$\Rightarrow (n-11)(n+8) = 0$$

$$\Rightarrow n = 11.$$

15. Ans. (b)

All permutations formed with 1, 2, 3, 4, 5 (sum = 15) will be divided by 3.

There are $5! = 120$ such permutations. Such numbers can also be formed using 0 and 1, 2, 4, 5. There are $4 \times 4!$ such numbers, i.e. 96. (Factor of 4 for four positions of 0 and 4! for different permutations of these four numbers)

$$\therefore \text{Total of such numbers} = 120 + 96 = 216.$$

16. Ans. (c)

$${}^7C_2 \times {}^6C_2 = 315.$$

17. Ans. (a)

$$= \frac{[1.3.5 \dots (2n-1)][2.4.6 \dots 2n]}{[2.4.6 \dots 2n]^2}$$

$$= \frac{(2n)!}{[2^n (1 \times 2 \times 3 \times \dots \times n)]^2} = \frac{(2n)!}{[2^n \times n!]^2}$$

18. Ans. (c)

$${}^5C_3 = {}^5C_2 = \frac{5 \times 4}{2 \times 1} = 10.$$

19. Ans. (c)

□□□□



Probability

Introduction

The probability has its origin in the problems dealing with games of chance such as gambling, coin tossing, die throwing and playing cards. In all these cases the outcome of a trial is uncertain. These days probability is widely used in business and economics in the field of prediction for future.

Lots of questions based on coins, die, playing cards and alphabetical arrangements are asked in various public sector examination.

Theory

Probability means the chance of occurrence of an event. In layman terms, we can say that it is likely hood that something that is defined as an event-will or will not occur mathematically,

$$\text{Probability (P)} = \frac{\text{Number of favourable event}}{\text{Total Number of event}}$$

for example probability of getting an even number after throwing a die can be calculated as.

$$(P) = \frac{\{2, 4, 6\}}{\{1, 2, 3, 4, 5, 6\}} = \frac{3}{6} = \frac{1}{2}$$

Were {2, 4, 6} are even numbers & hence favorable out comes and {1,2,3,4,5,6} etc. all 6 possible outcomes.

Similarly, we can calculate probability of getting a number divisible by 3 out of 9 single digit number in following manner Probability

$$= \frac{\text{Number divisible by 3}}{\text{All nine single digit number}}$$
$$= \frac{\{3, 6, 9\}}{\{1, 2, 3, 4, 5, 6, 7, 8, 9\}} = \frac{3}{9} \Rightarrow \frac{1}{3}$$

The followings remark may be important for learning this chapter on probability

1. **Die:** A die is small cube used in games of chance. On its six faces dots are marked numbering (1, 2, 3, 4, 5, 6)
2. **Playing card:** A pack (or deck) of playing cards has 52 cards, divided into four suits:
(1) Spades (2) Clubs
(3) Hearts (4) Diamonds

Each suit has 13 cards

- (a) Nine number cards 2, 3, 4, 5, 6, 7, 8, 9, 10
- (b) An Ace, a king, Queen and a jack or knave known as face cards

Ace - A King - K

Queen - Q Jack - J

Spade and clubs are black faced cards while Hearts and Diamonds are red- faced cards.

The King, Queens and Jacks are called court cards.

3. **Unbiased coin -** coin having two faces head (H) and Tail (T)

Some Basic Concepts

Random experiment

An experiment whose outcome has to be among a set of events that are completely known but whose exact outcome is unknown is random experiment.

Eg: (Throwing of a dice, tossing of a coin)

Sample Space

This is defined in the context of a random experiment and denotes the set representing all the possible outcomes of the random experiment.

Eg: 1. Sample Space when a coin is tossed is Head (H) or Tail (T)
2. Sample space when a dice is thrown is (1, 2, 3, 4, 5, 6)

Event

The set representing the desired outcome of a random experiment is called event. Event is subset of a sample space for example: Probability of getting a number divisible by 5 in a single throw of a die if odd numbers are obtained. Here sample space is (1, 2, 3, 4, 5, 6), event is (1, 3, 5) favourable outcome is (5) only.

$$\text{So probability} = \frac{\{5\}}{\{1, 3, 5\}} = \frac{1}{3}$$

Non Event

The outcome that is opposite of the desired event is the non-event.

Note: If the event occurs, the non-event does not occur and vice versa.

Impossible Event

An event that can never occur is an impossible event. The probability of an impossible event is 0.

Eg. (Probability of occurrence of 7 when a dice with 6 faces number 1-6 is thrown).

Mutually Exclusive Events

A set of event is mutually exclusive when the occurrence of any one of them means that the other events cannot occur.

Eg: 1. If head appears on a coin tail will not appear and vice versa
2. If 5 occurs in a single throw of a die then (1, 2, 3, 4, 6) will never appear.

Equally likely Events

If two events have the same probability or chance of occurrence they are called equally likely events.

Example: In a throw of a dice, the chance of 1 showing on the dice is equal to 2, is equal to 3, is equal to 4, is equal to 5, is equal to 6 appearing on the dice.

Exhaustive Set of Event

A set of events that includes all the possibilities of a sample space is said to be an exhaustive set of an events.

Example: In a throw of a dice the number is less than four or more than or equal to four.

Independent Events

An event is described as such if the occurrence of an event has no effect on the probability of occurrence of another event.

Example: If the first child of a couple is girl there is no effect on the chances of the second child being a girl.

Conditional Probability

Probability of the occurrence of an event A given that event B has already occurred.

This is denoted by P (A/B)

Example: The probability that in two throws of a dice we get a total of 7 or more given that in the first throw of the dices number 4 had occurred.

Concept of AND and OR

Whenever we use AND as the natural conjunction joining two separate parts of even definitions, we replace the AND by the multiplication sign.

Example: If probability of passing in an exam is $\frac{1}{2}$ for A and probability of passing the same is $\frac{1}{3}$ for B then probability of passing of A and B is $P(A) \times P(B)$

$$\text{i.e.: } \frac{1}{2} \times \frac{1}{3} = \frac{1}{6}$$

Whenever we use **OR** as the natural conjunction joining two separate parts of the event definition, we replace the **OR** by their addition sign.

Example: If we have the probability of A winning a race as $\frac{2}{3}$ and that of B as $\frac{1}{6}$ then probability that either A or B wins a race is given by

$$P(A) + P(B) = \frac{2}{3} + \frac{1}{6} = \frac{5}{6}$$

□□□□



Solved Example

- In throwing a fair dice, what is the probability of getting the number '3'?
 - $\frac{1}{3}$
 - $\frac{1}{6}$
 - $\frac{1}{9}$
 - $\frac{1}{12}$
- Find the chance of throwing at least one ace in a simple throw with two dice.
 - $\frac{1}{12}$
 - $\frac{1}{3}$
 - $\frac{1}{4}$
 - $\frac{11}{36}$
- Find the chance of drawing 2 blue balls in succession from a bag containing 5 red and 7 blue balls, if the balls are not being replaced.
 - $\frac{3}{13}$
 - $\frac{21}{64}$
 - $\frac{7}{22}$
 - $\frac{21}{61}$
- If a card is picked up at random from a pack of 52 cards. Find the probability that it is
 - a spade.
 - $\frac{1}{9}$
 - $\frac{1}{6}$
 - $\frac{1}{4}$
 - $\frac{1}{3}$
 - a king or queen.
 - $\frac{3}{13}$
 - $\frac{2}{13}$
 - $\frac{7}{52}$
 - $\frac{1}{169}$
 - 'a spade' or 'a king' or 'a queen'
 - $\frac{21}{52}$
 - $\frac{5}{13}$
 - $\frac{19}{52}$
 - none of these
- Three coins are tossed. What is the probability of getting 2 Tails and 1 Head
 - $\frac{1}{2}$
 - $\frac{3}{8}$
 - $\frac{2}{3}$
 - $\frac{3}{4}$
- For the above question, the probability that there is at least one tail is :
 - $\frac{2}{3}$
 - $\frac{7}{8}$
 - $\frac{3}{8}$
 - $\frac{1}{2}$
- A bag contains 3 green and 7 white balls. Two balls are drawn from the bag in succession without replacement.
 - What is the probability that both are white?
 - $\frac{1}{7}$
 - $\frac{5}{11}$
 - $\frac{7}{11}$
 - $\frac{7}{15}$

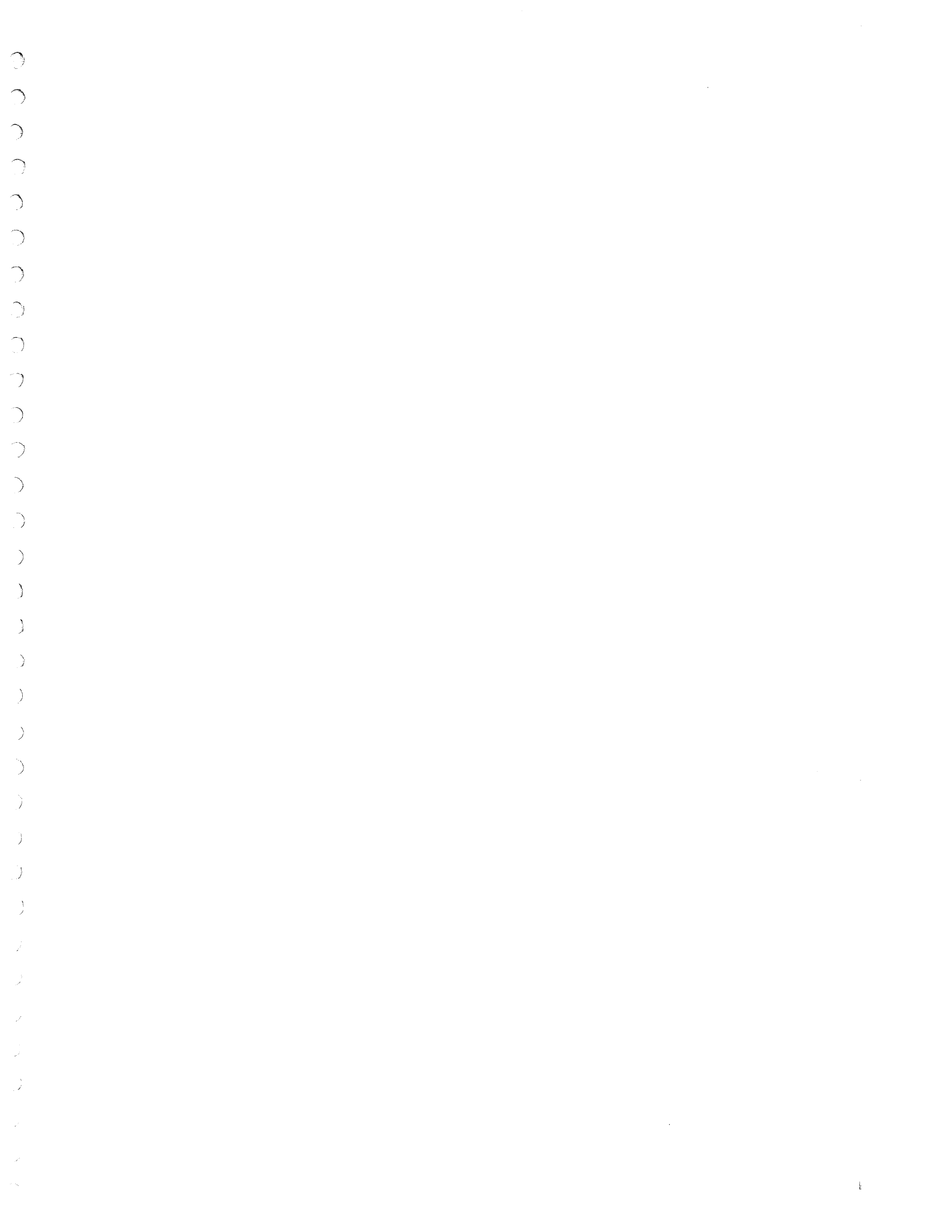

- (ii) What is the probability that both are different colour?
- (a) $\frac{1}{7}$ (b) $\frac{5}{11}$
 (c) $\frac{7}{11}$ (d) $\frac{7}{15}$
8. What is the probability of throwing a number greater than 2 with a fair dice?
- (a) $\frac{2}{3}$ (b) $\frac{2}{5}$
 (c) 1 (d) $\frac{3}{5}$
9. Three cards numbered 2, 4 and 8 are put into a box. If a card is drawn at random, what is the probability that the card drawn is
- (i) a prime number?
- (a) 1 (b) $\frac{1}{3}$
 (c) $\frac{4}{5}$ (d) $\frac{5}{7}$
- (ii) an even number?
- (a) 1 (b) $\frac{2}{3}$
 (c) $\frac{1}{2}$ (d) $\frac{3}{5}$ and
- (iii) an odd number?
- (a) 1 (b) 0
 (c) $\frac{1}{3}$ (d) $\frac{2}{3}$
10. Two fair coins are tossed. Find the probability of obtaining
- (i) 2 Heads
- (a) 1 (b) $\frac{2}{3}$
 (c) $\frac{1}{2}$ (d) $\frac{1}{4}$
- (ii) 1 Head and 1 Tail
- (a) $\frac{1}{4}$ (b) 1
 (c) $\frac{1}{2}$ (d) $\frac{2}{3}$
- (iii) 2 Tails
- (a) 1 (b) $\frac{1}{4}$
 (c) $\frac{2}{3}$ (d) $\frac{1}{2}$
11. In rolling two dices, find the probability that
- (i) there is at least one '6'
- (a) $\frac{11}{36}$ (b) $\frac{22}{36}$
 (c) $\frac{15}{36}$ (d) $\frac{29}{36}$
- (ii) the sum is 5
- (a) $\frac{1}{4}$ (b) $\frac{1}{9}$
 (c) $\frac{1}{2}$ (d) $\frac{1}{6}$
12. From a bag containing 4 white and 5 black balls a man draws 3 at random. What are the odds against these being all black?
- (a) $\frac{5}{37}$ (b) $\frac{37}{5}$
 (c) $\frac{11}{13}$ (d) $\frac{13}{37}$
13. Two balls are to be drawn from a bag containing 8 grey and 3 blue balls. Find the chance that they will both be blue.
- (a) $\frac{1}{5}$ (b) $\frac{3}{55}$
 (c) $\frac{11}{15}$ (d) $\frac{14}{45}$

14. Two fair dice are thrown. What is the probability of

(i) throwing a double?

(a) $\frac{1}{6}$ (b) 1

(c) $\frac{2}{3}$ (d) $\frac{1}{2}$

(ii) the sum is greater than 10

(a) $\frac{2}{3}$ (b) $\frac{2}{5}$

(c) $\frac{1}{6}$ (d) $\frac{1}{12}$

(iii) the sum is less than 10?

(a) $\frac{5}{6}$ (b) $\frac{2}{5}$

(c) $\frac{3}{5}$ (d) $\frac{2}{3}$

15. A bag contains four black and five red balls. If three balls from the bag are chosen at random, what is the chance that they are all black?

(a) $\frac{1}{21}$ (b) $\frac{1}{20}$

(c) $\frac{2}{23}$ (d) $\frac{1}{9}$

16. If a number of two digits is formed with the digits 2, 3, 5, 7, 9 without repetition of digits, what is the probability that the number formed is 35?

(a) $\frac{1}{10}$ (b) $\frac{1}{20}$

(c) $\frac{2}{11}$ (d) $\frac{1}{11}$

17. From a pack of 52 playing cards, three cards are drawn at random. Find the probability of drawing a king, a queen and jack.

(a) $\frac{16}{5525}$ (b) $\frac{1}{13^3}$

(c) $\frac{1}{14^3}$ (d) $\frac{1}{15^3}$

18. A bag contains 3 red, 6 white and 7 black balls. Two balls are drawn at random. What is the probability that both are black?

(a) $\frac{1}{8}$ (b) $\frac{7}{40}$

(c) $\frac{12}{40}$ (d) $\frac{13}{40}$

19. A bag contains 4 white and 2 black balls. Another contains 3 white and 5 black balls. If one ball is drawn from each bag, find the probability that

(i) both are white.

(a) $\frac{1}{3}$ (b) $\frac{2}{3}$

(c) $\frac{1}{4}$ (d) $\frac{3}{4}$

(ii) both are black.

(a) $\frac{3}{24}$ (b) $\frac{1}{24}$

(c) $\frac{3}{12}$ (d) $\frac{5}{24}$

(iii) one is white and one is black.

(a) $\frac{13}{24}$ (b) $\frac{15}{24}$

(c) $\frac{11}{21}$ (d) $\frac{1}{2}$

Solutions

1. Ans. (b)

2. Ans. (d)

Ace is nothing but 6. we can get it in 11 different ways (1,6), (6,1), (2, 6), (6, 2), (3, 6), (6, 3), (4, 6), (6, 4), (5, 6), (6, 5), (6, 6)

$$\Rightarrow \frac{11}{36} \text{ (Probability)}$$

3. Ans. (c)

Probability of getting blue ball in single draw

is $\frac{7}{12}$ and probability of getting blue ball in

second draw is $\frac{6}{11}$ so $\frac{7}{12} \times \frac{6}{11} = \frac{7}{22}$

4. (i) Ans. (c)

(ii) Ans. (b)

(iii) Ans. (c)

$$(i) \frac{13}{52} = \frac{1}{4}$$

(ii) 4 king or 4 Queen = 8

$$\Rightarrow \frac{8}{52} = \frac{2}{13}$$

(iii) Spade = 13, King = 4 Queen = 4 but there will 1 King of spade & 1 Queen of spade so we have 19 to choose from

$$\Rightarrow \frac{19}{52}$$

5. Ans. (b)

When three coins are tossed we get

- | | | |
|-----|----|-----|
| HHH | or | (1) |
| HHT | or | (2) |
| HTT | or | (3) |
| HTH | or | (4) |
| THH | or | (5) |
| THT | or | (6) |
| TTT | or | (7) |
| TTH | or | (8) |

We get 2T and one H in 3 cases so probability

$$= \frac{3}{8}$$

6. Ans. (b)

For at least one tail, we have to exclude the case of all Heads {H, H, H} and rest 7 are favourable.

$$\text{So } P = \frac{7}{8}$$

7. (i) Ans. (d)

(ii) Ans. (d)

(i) To get both white

$$\frac{{}^7C_2}{{}^{10}C_2} = \frac{21}{45} = \frac{7}{15}$$

(ii) To get balls of different colour

$$P = \frac{{}^3C_1 \times {}^7C_1}{{}^{10}C_2} = \frac{3 \times 7}{45} = \frac{7}{15}$$

8. Ans. (a)

Number greater than 2 = {3, 4, 5, 6}

$$\text{So } P = \frac{4}{6} = \frac{2}{3}$$

9. (i) Ans. (b)

(ii) Ans. (a)

(iii) Ans. (b)

(i) In (2, 4, 8) 2 is the only prime number

$$\text{So } P = \frac{1}{3}$$

(ii) Probability for even number $\frac{\{2,4,8\}}{\{2,4,8\}} = 1$

(iii) No odd number is given in the sample
So, $P = 0$

10. (i) Ans. (d)

(ii) Ans. (c)

(iii) Ans. (b)

When two coins are tossed then four outcomes are

HH, HT, TH, or TT

(i) $P = \frac{1}{4}$

(ii) $P = \frac{2}{4} = \frac{1}{2}$

(iii) $P = \frac{1}{4}$

11. (i) Ans. (a)

(ii) Ans. (b)

Rolling two dice gives following sums

- Two (1, 1)
- Three (1, 2), (2, 1)
- Four (1, 3), (3, 1), (2, 2)
- Five (1, 4), (2, 3), (3, 2), (4, 1)
- Six (1, 5), (5, 1), (2, 4), (4, 2), (3, 3)
- Seven (1, 6), (6, 1), (5, 2), (2, 5), (4, 3), (3, 4)
- Eight (6, 2), (2, 6), (5, 3), (3, 5), (4, 4)
- Nine (6, 3), (3, 6), (5, 4), (4, 5)
- Ten (4, 6), (4, 6), (5, 5)
- Eleven (6, 5), (5, 6)
- Twelve (6, 6)

(i) $P = \frac{11}{36}$

(ii) $P = \frac{4}{36} = \frac{1}{9}$

12. Ans. (b)

Probability that all 3 balls are black

$$\frac{5C_3}{9C_3} = \frac{10}{84} = \frac{5}{42} \text{ out of 42 cases only 5 are}$$

favourable and 37 are not favourable so odd

against these being all black is $\frac{37}{5}$

13. Ans. (b)

8 grey and 3 blue balls

$$\text{probability that all are black} = \frac{3C_2}{11C_2} = \frac{3}{55}$$

14. (i) Ans. (a)

(ii) Ans. (d)

(iii) Ans. (a)

(i) Cases of double are

(1, 1), (2, 2), (3, 3), (4, 4), (5, 5) and (6, 6)

$$P = \frac{6}{36} = \frac{1}{6}$$

(ii) 11 & 12 are only favourable sums so

$$P = \frac{3}{36} = \frac{1}{12}$$

(iii) $P = \frac{30}{36} = \frac{5}{6}$

15. Ans. (a)

4 black and 5 red balls to get all black

$$P = \frac{4C_3}{9C_3} = \frac{4}{84} = \frac{1}{21}$$

16. Ans. (b)

Total two digit numbers formed = $5P_2 = 20$,

So probability this number being 35 is $\frac{1}{20}$

17. Ans. (a)

$$P = \frac{4C_1 \times 4C_1 \times 4C_1}{52C_3} = \frac{64}{22100} = \frac{16}{5525}$$

18. Ans. (b)

Here 3 red, 6 white & 7 black balls

$$P = \frac{7C_2}{16C_2} = \frac{21}{120} = \frac{7}{40}$$

19. (i) Ans. (c)

(ii) Ans. (d)

(iii) Ans. (a)

Bag 1 → 4 white, 2 black and

Bag 2 → 3 white & 5 black ball

- (i) Probability of getting both white

$$\frac{4}{6} \times \frac{3}{8} = \frac{1}{4}$$

- (ii) Probability of getting both black

$$= \frac{2}{6} \times \frac{5}{8} = \frac{5}{24}$$

$$(iii) \frac{4}{6} \times \frac{5}{8} + \frac{2}{6} \times \frac{3}{8} = \frac{13}{24}$$

□□□□

Probability



Practice Exercise: I

- In a simultaneous toss of two coins, find the probability of 2 tails.
 - $\frac{1}{2}$
 - $\frac{1}{4}$
 - $\frac{3}{4}$
 - $\frac{1}{3}$
- Three coins are tossed. Find the probability of all heads.
 - $\frac{1}{6}$
 - $\frac{1}{8}$
 - $\frac{1}{4}$
 - None of these.
- Three coins are tossed. Find the probability of no heads.
 - $\frac{3}{8}$
 - $\frac{1}{8}$
 - $\frac{1}{2}$
 - None of these
- A coin is tossed three times. Find the chance that head and tail show alternately.
 - $\frac{3}{8}$
 - $\frac{1}{4}$
 - $\frac{1}{8}$
 - None of these
- In a single throw of two dice, find the probability of getting a total of 3 or 5.
 - $\frac{1}{3}$
 - $\frac{2}{3}$
 - $\frac{1}{6}$
 - $\frac{5}{6}$
- In a single throw of two dice, find the probability of getting a total of 12.
 - $\frac{1}{36}$
 - $\frac{1}{9}$
 - $\frac{1}{18}$
 - $\frac{35}{36}$
- In a single throw of two dice, what is the probability of a doublet?
 - $\frac{1}{6}$
 - $\frac{5}{6}$
 - $\frac{1}{9}$
 - $\frac{1}{18}$
- A sum less than 6 in throw of two dice, find probability
 - $\frac{7}{18}$
 - $\frac{5}{18}$
 - $\frac{1}{3}$
 - $\frac{4}{9}$
- An even number as the sum.
 - $\frac{1}{36}$
 - $\frac{1}{4}$
 - $\frac{1}{2}$
 - $\frac{1}{3}$

10. A multiple of 3 as the sum

- (a) $\frac{2}{3}$ (b) $\frac{1}{3}$
(c) $\frac{1}{9}$ (d) $\frac{5}{36}$

11. Sum as a prime number

- (a) $\frac{5}{12}$ (b) $\frac{1}{2}$
(c) $\frac{7}{12}$ (d) $\frac{3}{4}$

(For Question No. 12-14)

In a single throw of three dice, find the probability of getting.

12. A total of 5?

- (a) $\frac{1}{4}$ (b) $\frac{1}{18}$
(c) $\frac{1}{36}$ (d) $\frac{1}{9}$

13. A total of at most 5.

- (a) $\frac{5}{108}$ (b) $\frac{103}{108}$
(c) $\frac{1}{18}$ (d) None of these

14. A total of at least 5.

- (a) $\frac{7}{54}$ (b) $\frac{1}{54}$
(c) $\frac{53}{54}$ (d) None of these

15. What is the chance that a leap year, selected at random will contain 53 Sunday?

- (a) $\frac{1}{7}$ (b) $\frac{2}{7}$
(c) $\frac{3}{7}$ (d) $\frac{4}{7}$

16. The letters of word "SOCIETY" are placed in a row. What is the probability that three vowels come together ?

- (a) $\frac{3}{7}$ (b) $\frac{2}{7}$
(c) $\frac{1}{7}$ (d) None of these

17. Find the probability that in a random arrangement of letter of the words "UNIVERSITY" two 'I's do not come together.

- (a) $\frac{4}{5}$ (b) $\frac{1}{5}$
(c) $\frac{3}{5}$ (d) $\frac{2}{3}$

18. Two dice are thrown. Find the odds in favour of getting the sum 5.

- (a) 8:1 (b) 1:8
(c) 7:8 (d) 8:7

19. An interger is chosen at random from first two hundred natural numbers. What is the probability that the integer chosen is divisible by 6 or 8?

- (a) $\frac{1}{4}$ (b) $\frac{3}{4}$
(c) $\frac{1}{2}$ (d) None of these.

20. In a simultaneous throw of two dice, find $P(A \text{ or } B)$ if A denotes the event 'a total of 11 and B denotes the event 'an odd number on each die'.

- (a) $\frac{11}{36}$ (b) $\frac{1}{4}$
(c) $\frac{5}{18}$ (d) $\frac{1}{6}$

21. Two dice are thrown together. What is the probability that the sum of number on two faces is neither 9 nor 11?

- (a) $\frac{1}{6}$ (b) $\frac{5}{6}$
 (c) $\frac{2}{3}$ (d) $\frac{1}{2}$

22. A and B are mutually exclusive events of an experiment. If $P(\text{'not } A) = 0.65$, $P(A \cup B) = 0.65$ and $P(B) = p$, find the value of p .

- (a) 0.70 (b) 0.30
 (c) 0.63 (d) 0.35

23. The probabilities that a student will receive an A , B , C or D grade are 0.30, 0.38, 0.22 and 0.01, respectively. What is the probability that the student will receive at least B grade?

- (a) 0.38 (b) 0.42
 (c) 0.68 (d) None of these.

24. A card is drawn from an ordinary pack and a gambler bets that it is a spade or an ace. What are the odds against his winning the bet?

- (a) 9 : 4 (b) 4 : 9
 (c) 5 : 9 (d) 9 : 5

25. A problem in Statistics is given to four students A , B , C and D . Their chances of

solving it are $\frac{1}{3}$, $\frac{1}{4}$, $\frac{1}{5}$, and $\frac{1}{6}$, respectively.

What is the probability that the problem will be solved?

- (a) $\frac{1}{3}$ (b) $\frac{2}{3}$
 (c) $\frac{4}{5}$ (d) None of these.

(For Question No. 26-28)

An urn contains 25 balls numbered 1 to 25. Suppose an odd number is considered a 'success'. Two balls are drawn from the urn with replacement.

26. Find the probability of getting two successes.

- (a) $\frac{169}{625}$ (b) $\frac{312}{625}$
 (c) $\frac{481}{625}$ (d) $\frac{144}{625}$

27. Find the probability of getting no success.

- (a) $\frac{169}{625}$ (b) $\frac{312}{625}$
 (c) $\frac{481}{625}$ (d) $\frac{144}{625}$

28. Find the probability of getting at most 2 successes.

- (a) $\frac{1}{27}$ (b) $\frac{2}{9}$
 (c) 1 (d) $\frac{7}{27}$

(For Question No. 29-32)

A husband and wife appear in an interview for two vacancies in the same post. The probability of husband's selection is $\frac{1}{7}$ and that of wife's is $\frac{1}{5}$.

29. What is the probability that only one of them will be selected?

- (a) $\frac{2}{7}$ (b) $\frac{1}{35}$
 (c) $\frac{24}{25}$ (d) $\frac{11}{35}$

30. What is the probability that both of them will be selected?

- (a) $\frac{2}{7}$ (b) $\frac{1}{35}$
 (c) $\frac{24}{35}$ (d) $\frac{11}{35}$

31. What is the probability that none of them will be selected?

- (a) $\frac{2}{7}$ (b) $\frac{1}{35}$
(c) $\frac{24}{35}$ (d) $\frac{11}{35}$

32. What is the probability that at least one of them will be selected?

- (a) $\frac{2}{7}$ (b) $\frac{1}{35}$
(c) $\frac{24}{35}$ (d) $\frac{11}{35}$

33. A man speaks truth in 80% of the cases and another in 90% of the cases. While stating the same fact, what is the probability that they contradict?

- (a) $\frac{37}{50}$ (b) $\frac{13}{50}$
(c) $\frac{16}{50}$ (d) None of these

34. A can solve 90% of the problems given in a book and B solve 70%. What is the probability that at least one of them will solve a problem selected at random from the book?

- (a) $\frac{3}{100}$ (b) $\frac{97}{100}$
(c) $\frac{83}{100}$ (d) $\frac{17}{100}$

35. Find the probability that in a random arrangement of the letters of the word DAUGHTER, the letter D occupies the first place.

- (a) $\frac{1}{8}$ (b) $\frac{1}{4}$
(c) $\frac{3}{8}$ (d) $\frac{1}{2}$

Solutions

1. Ans. (b)

Sample space $S = \{HH, HT, TH, TT\}$

Number of exhaustive cases = 4

There is only one favourable case TT.

$$\therefore P(2 \text{ tails}) = \frac{1}{4}$$

2. Ans. (b)

Sample space $S = \{HHH, HHT, HTH, HTT, THT, TTH, THH, TTT\}$

Number of exhaustive cases = 8

There is only one favourable case HHH.

$$\therefore P(\text{all heads}) = \frac{1}{8}$$

3. Ans. (b)

Sample space $S = \{HHH, HHT, HTH, HTT, THT, TTH, THH, TTT\}$

Number of exhaustive cases = 8

$$P(\text{no heads}) = P(\text{all tails}) = \frac{1}{8}$$

(\because there is only favourable case TTT).

4. Ans. (b)

Sample space $S = \{HHH, HHT, HTH, HTT, THT, TTH, THH, TTT\}$

Number of exhaustive cases = 8

Favourable cases are HTH, THT

Number of favourable = 2.

$$\therefore \text{Required probability} = \frac{2}{8} = \frac{1}{4}$$

5. Ans. (c)

A total of 3 or 5 may be obtained in 6 ways, viz, (1, 2), (2, 1), (1, 4), (2, 3), (3, 2), (4, 1).

No. of exhaustive cases = $6 \times 6 = 36$.

\therefore Probability of getting a total of 3

$$\text{or } 5 = \frac{6}{36} = \frac{1}{6}$$

6. Ans. (a)

A total of 12 may be obtained in 1 way, viz, (6, 6).

$$\therefore \text{Required probability} = \frac{1}{36}$$

7. Ans. (a)

A 'doublet' means that both the dice show the same number on the upper most faces. Therefore, the outcomes, favourable to this event are (1, 1), (2, 2), (3, 3), (4, 4), (5, 5), (6, 6)

Thus, the number of favourable cases = 6.

$$\text{Hence, } P(\text{doublet}) = \frac{6}{36} = \frac{1}{6}$$

8. Ans. (b)

A : Getting total less than 6

$A = [(1, 1), (1, 2), (2, 1), (2, 2), (3, 1), (1, 3), (4, 1), (1, 4), (3, 2), (2, 3)]$

$$n(A) = 10, n(S) = 36$$

\therefore Required probability

$$= P(A) = \frac{n(A)}{n(S)} = \frac{10}{36} = \frac{5}{18}$$

9. Ans. (c)

A = Getting even number as the sum

$A = [(1, 1), (1, 3), (3, 1), (2, 2), (3, 3), (4, 2), (2, 4), (5, 1), (1, 5), (6, 2), (2, 6), (5, 3), (3, 5), (4, 4), (5, 5), (6, 4), (4, 6), (6, 6)]$

$$n(A) = 18, n(S) = 36$$

\therefore Required probability

$$= P(A) = \frac{n(A)}{n(S)} = \frac{18}{36} = \frac{1}{2}$$

10. Ans. (b)

A : Getting a multiple of 3 as the sum

(1, 2), (2, 1), (3, 3), (5, 1), (1, 5), (4, 2), (2, 4), (6, 3), (3, 6), (4, 5), (5, 4), (6, 6)

$$n(A) = 12, n(S) = 36$$

\therefore Required probability

$$= P(A) = \frac{n(A)}{n(S)} = \frac{12}{36} = \frac{1}{3}$$

11. Ans. (a)

A : Getting sum as a prime number

$A = [(1, 1), (1, 2), (2, 1), (2, 3), (3, 2), (4, 1), (1, 4), (4, 3), (3, 4), (6, 1), (1, 6), (5, 2), (2, 5), (6, 5), (5, 6)]$

$$n(A) = 11, n(S) = 36$$

\therefore Required probability

$$= P(A) = \frac{n(A)}{n(S)} = \frac{11}{36} = \frac{5}{12}$$

12. Ans. (c)

Number of exhaustive cases in a single throw of three dice = $6 \times 6 \times 6 = 216$.

Cases favourable to a total of 5 are (1,2,2), (2,1,2), (2,2,1), (1,1,3), (1,3,1), (3,1,1).

$$\therefore P(\text{a total of 5}) = \frac{6}{216} = \frac{1}{36}$$

13. Ans. (a)

A total of at most 5 means a total 3, 4 or 5.

Cases favourable to a total of 3 are (1,1,1)

Cases favourable to a total of 4 are (1,1,2), (1,2,1), (2,1,1)

Cases favourable to a total of 5 are (1, 2, 2), (2, 1, 2), (2, 2, 1), (1, 1, 3), (1, 3, 1), (3, 1, 1).

Number of cases favourable to a total of 3 or 4 or 5 is 10.

$$\therefore P(\text{a total of at most 5}) = \frac{10}{216} = \frac{5}{108}$$

14. Ans. (c)

A total of at least 5 means not a total of 3 or 4. number of cases favourable to a total of 3 or 4 is 4.

$$P(\text{a total of 3 or 4}) = \frac{4}{216} = \frac{1}{54}$$

$$\begin{aligned} \therefore P(\text{a total of at least 5}) &= P(\text{not a total of 3 or 4}) \\ &= 1 - P(\text{a total of 3 or 4}) \end{aligned}$$

$$= 1 - \frac{1}{54} = \frac{53}{54}$$

15. Ans. (b)

We know that a leap year has 366 days and thus a leap year has 52 weeks and 2 days over.

The two over (successive days have the following likely cases:

- (i) Sunday and Monday
- (ii) Monday and Tuesday
- (iii) Tuesday and Wednesday
- (iv) Wednesday and Thursday
- (v) Thursday and Friday
- (vi) Friday and Saturday
- (vii) Saturday and Sunday

∴ Number of exhaustive cases 'n' = 7.

Out of these, the favourable cases are (i) and (vii)

∴ Number of favourable cases 'm' = 2

∴ Probability of having 53 Sunday = $\frac{2}{7}$.

16. Ans. (c)

There are 7 letters in the word 'SOCIETY' which can be arranged in 7! ways. Considering the three vowels in the word 'SOCIETY' as one letter, we can arrange 5 letters in a row in 5! ways. Also, three vowels can themselves be arranged in 3! ways.

∴ The total number of arrangements in which three vowels come together are 5! × 3!

Hence, the required probability = $\frac{5! \times 3!}{7!}$

$$= \frac{3 \times 2 \times 1}{7 \times 6} = \frac{1}{7}$$

17. Ans. (a)

Out of the letters in the word 'UNIVERSITY' two letters 'I' are alike.

∴ Number of permutations = $\frac{10!}{2}$... (i)

Number of words in which two 'I' are never together = Total number of words – Number of words in which two 'I' are together

$$\frac{10!}{2} - 9! = \frac{10! - 2 \cdot 9!}{2} = \frac{9! [10 - 2]}{2} = \frac{9! \cdot 8}{2} = 9! \cdot 4$$

$$\therefore \text{Required probability} = \frac{9! \cdot 8}{10! / 2} = \frac{9! \cdot 8}{10!}$$

$$= \frac{8}{10} = \frac{4}{5}$$

18. Ans. (b)

Let A be the event of "getting the sum 5".

Then, A = [(1, 4), (4, 1), (2, 3), (3, 2)].

There are 4 favourable outcomes and (36 – 4) = 32 outcomes are unfavourable.

$$\therefore \text{Odds in favour of sum 5} = \frac{4}{32} = \frac{1}{8}$$

19. Ans. (a)

A: Integer chosen is divisible by 6
B: Integer chosen is divisible by 8

n(A) = 33, n(B) = 25, n(A ∩ B) = 8, n(S) = 200

$$P(A) = \frac{33}{200}, P(B) = \frac{25}{200}$$

$$P(A \cup B) = P(A) + P(B) - P(A \cap B)$$

$$= \frac{33}{200} + \frac{25}{200} - \frac{8}{200} = \frac{50}{200} = \frac{1}{4}$$

20. Ans. (a)

A: Getting total of 11
B: Getting odd number on each die

A = [(6, 5), (5, 6)]

B = [(1, 1), (1, 3), (1, 5), (3, 1), (3, 3), (3, 5), (5, 1), (5, 3), (5, 5)]

$$P(A) = \frac{2}{36}, P(B) = \frac{9}{36}, P(A \cap B) = 0$$

∴ Required probability

$$= P(A) + P(B) - P(A \cap B)$$

$$= \frac{2}{36} + \frac{9}{36} - 0 = \frac{11}{36}$$

21. Ans. (b)

A: Getting a total of 9, B: getting a total of 11
 $A = [(5, 4), (4, 5), (6, 3), (3, 6)]$ $B = [(6, 5), (5, 6)]$

$$P(A) = \frac{4}{36}, P(B) = \frac{2}{36}, P(A \cap B) = \frac{0}{36}$$

\therefore Required probability = $1 - P(A \cup B)$

$$= 1 - [P(A) + P(B) - P(A \cap B)]$$

$$= 1 - \left(\frac{4}{36} + \frac{2}{36} - 0 \right)$$

$$= 1 - \frac{1}{6} = \frac{5}{6}$$

22. Ans. (b)

We know $P(A) = 1 - P(\bar{A})$

$$= 1 - 0.65 = 0.35 \text{ and}$$

$$P(A \cup B) = P(A) + P(B) - P(A \cap B)$$

$$\Rightarrow 0.65 = 0.35 + P - 0$$

[\because A and B are mutually exclusive events]

$$\Rightarrow P = 0.65 - 0.35 = 0.30$$

23. Ans. (c)

$P(\text{at least } B \text{ grade}) = P(B \text{ grade}) + P(A \text{ grade}) = 0.38 + 0.30 = 0.68$.

24. Ans. (a)

Let A : a sapde is drawn and B: an ace is drawn

Probability of winning the bet = $P(A \text{ or } B)$

$$= P(A) + P(B) - P(A \text{ and } B)$$

$$= \frac{13}{52} + \frac{4}{52} - \frac{1}{52} = \frac{16}{52} = \frac{4}{13}$$

$$\text{Probability of losing the bet} = 1 - \frac{4}{13} = \frac{9}{13}$$

Odds against winning the bet

$$= \frac{9}{13} : \frac{4}{13} = 9 : 4$$

25. Ans. (b)

Probability that A fails to solve the problem

$$\text{is } 1 - \frac{1}{3} = \frac{2}{3}$$

Probability that B fails to solve the problem

$$\text{is } 1 - \frac{1}{4} = \frac{3}{4}$$

Probability that C fails to solve the problem

$$\text{is } 1 - \frac{1}{5} = \frac{4}{5}$$

Probability that D fails to solve the problem

$$\text{is } 1 - \frac{1}{6} = \frac{5}{6}$$

Since the events are independent, the probability that all the four students fail to solve the problem is

$$\frac{2}{3} \times \frac{3}{4} \times \frac{4}{5} \times \frac{5}{6} = \frac{1}{3}$$

\therefore The probability that the problem will be

$$\text{solved} = 1 - \frac{1}{3} = \frac{2}{3}$$

26. Ans. (a)

Success: Getting odd number $P = \frac{13}{25}$

$$\Rightarrow q = 1 - P = 1 - \frac{13}{25} = \frac{12}{25}$$

$P(\text{two successes}) = pp$

$$= \frac{13}{25} \times \frac{13}{25} = \frac{169}{625}$$

27. Ans. (d)

$$P(\text{no success}) = qq = \frac{12}{25} \left(\frac{12}{25} \right) = \frac{144}{625}$$

3. If the probability that A will live 15 years is $\frac{7}{8}$ and that B will live 15 years is $\frac{9}{10}$, then what is the probability that both will live after 15 years?
- (a) $\frac{1}{20}$ (b) $\frac{63}{80}$
 (c) $\frac{1}{5}$ (d) None of these
4. Suppose six coins are flipped. Then the probability of getting at least one tail is
- (a) $\frac{71}{72}$ (b) $\frac{53}{54}$
 (c) $\frac{63}{64}$ (d) $\frac{1}{12}$
5. The probability that a student is not a swimmer is $\frac{1}{5}$. Then the probability that out of the five students, four are swimmers, is
- (a) ${}^5C_4 \left(\frac{4}{5}\right)^2 \left(\frac{1}{5}\right)$ (b) $\left(\frac{4}{5}\right)^4 \left(\frac{1}{5}\right)$
 (c) ${}^5C_1 \left(\frac{1}{5}\right) \left(\frac{4}{5}\right)^4$ (d) None of these
6. If events A and B are independent and $P(A) = 0.15$, $P(A \cup B) = 0.45$ then $P(B) =$
- (a) $\frac{6}{13}$ (b) $\frac{6}{17}$
 (c) $\frac{6}{19}$ (d) $\frac{6}{23}$
7. The probability that a marksman will hit a target in given as $\frac{1}{5}$. Then, his probability of atleast one hit in 10 shots is
- (a) $\frac{1}{6^{10}}$ (b) $1 - \left(\frac{4}{5}\right)^{10}$
 (c) $1 - \frac{1}{5^{10}}$ (d) $1 - \frac{1}{5^{19}}$
8. Two dice are tossed. The probability that the total score is a prime number is
- (a) $\frac{1}{6}$ (b) $\frac{5}{12}$
 (c) $\frac{1}{2}$ (d) $\frac{7}{9}$
9. Four different objects 1, 2, 3, 4 are distributed at random in four places marked 1, 2, 3, 4. What is the probability that none of the objects occupy the place corresponding to its number?
- (a) $\frac{17}{24}$ (b) $\frac{3}{8}$
 (c) $\frac{1}{2}$ (d) $\frac{5}{8}$
10. If the probability of rain on any given day in Pune city is 50%, then what is the probability that it rains on exactly 3 days in a 5-day period?
- (a) $\frac{8}{125}$ (b) $\frac{5}{16}$
 (c) $\frac{8}{25}$ (d) $\frac{2}{25}$
11. The probability that an event A happens in one trial of an experiment is 0.4. Three independent trial of the experiment are formed. The probability that the event A happens at least once is
- (a) 0.934 (b) 0.784
 (c) 0.548 (d) 0.343
12. A number is chosen at random among the first 120 natural numbers. The probability of the number chosen being a multiple of 5 or 15 is
- (a) $\frac{1}{5}$ (b) $\frac{1}{6}$
 (c) $\frac{1}{7}$ (d) $\frac{1}{9}$
13. From a pack of 52 playing cards, two cards are drawn together at random. Calculate the probability of both the cards being Kings.
- (a) $\frac{1}{15}$ (b) $\frac{25}{57}$
 (c) $\frac{35}{256}$ (d) None of these
14. What is the possibility of getting at least 6 heads if eight coins are tossed simultaneously?
- (a) $\frac{37}{256}$ (b) $\frac{25}{57}$
 (c) $\frac{1}{13}$ (d) None of these

15. From a box containing 60 standard and 40 substandard article, two articles are chosen at random. What is the probability that one of them is standard and the other substandard?

- (a) $\frac{60}{100} \times \frac{40}{100}$ (b) $\frac{60}{100} \times \frac{39}{100}$
 (c) $\frac{16}{33}$ (d) 24%
 (e) None of these

Solutions

1. Ans. (c)

$$0.2 \times 0.3 = 0.06.$$

2. Ans. (a)

The probability that the ball drawn is of green

$$\text{colour} = \frac{4}{24} = \frac{1}{6}$$

Probability that the ball drawn is not of green

$$\text{colour} = 1 - \frac{1}{6} = \frac{5}{6}.$$

3. Ans. (b)

$$P(A) \times P(B) = \frac{7}{8} \times \frac{9}{10} = \frac{63}{80}.$$

4. Ans. (c)

Total number of events that would occur by flipping six coins = $2^6 = 64$.

$$\text{Probability that no tail occurs} = \frac{1}{64}$$

∴ Probability of occurring at least one tail

$$= 1 - \frac{1}{64} = \frac{63}{64}.$$

5. Ans. (b)

6. Ans. (b)

$$P(A \cap B) = P(A) \times P(B) = 0.15 \times P(B)$$

$$P(A \cup B) = P(A) + P(B) - P(A \cap B)$$

$$0.45 = 0.15 + P(B) - (0.15) \times P(B)$$

$$= 0.15 + P(B)(1 - 0.15)$$

$$= 0.15 + 0.85P(B)$$

$$\therefore 0.85P(B) = 0.45 - 0.15 = 0.30$$

$$\therefore P(B) = \frac{0.30}{0.85} = \frac{30}{85} = \frac{6}{17}.$$

7. Ans. (b)

$$P(A) = \frac{1}{5}, P(\bar{A}) = 1 - \frac{1}{5} = \frac{4}{5}$$

The probability that he will not hit the target

in 10 shots is $\left(\frac{4}{5}\right)^{10}$. So, Probability that

at least once target will be hit = $1 - \left(\frac{4}{5}\right)^{10}$.

8. Ans. (b)

The event "Total score is a prime number when two dice are tossed" occurs in the following 15 ways: (1, 1), (1, 2), (1, 4), (1, 6), (2, 1), (2, 3), (2, 5), (3, 2), (3, 4), (4, 1), (4, 3), (5, 2), (5, 6), (6, 1), (6, 5).

$$\therefore \text{Required probability} = \frac{15}{36} = \frac{5}{12}.$$

9. Ans. (c)

Let the four places be

1	2	3	4
---	---	---	---

Now object i cannot occupy the place i (A)

Suppose object 2 occupies the place

1

Then other placements can be done in 6 ways as follows:

(1)	2	1	3	4
(2)	2	1	4	3
(3)	2	3	1	4
(4)	2	3	4	1
(5)	2	4	1	3
(6)	2	4	3	1

Here out of the six ways, only three are permissible, because (1), (3) and (6) are not permissible because of the non-fulfilment of condition (A). Hence, required probability is

$$\frac{3}{6} = \frac{1}{2}. \text{ Similarly you can allow objects 3 and}$$

4 to occupy place 1 and in each case you can find that the probability is $1/2$.

10. Ans. (b)

$$\text{Prob. that it rains on the 1st day} = \frac{1}{2}$$

$$\text{Prob. that it rains on the 2nd day} = \frac{1}{2}$$

$$\text{Prob. that it rains on the 3rd day} = \frac{1}{2}$$

$$\text{Prob. that it rains on the 4th day} = \frac{1}{2}$$

$$\text{Prob. that it rains on the 5th day} = \frac{1}{2}$$

Prob. that it rains on the any day in a 5-day

$$\text{period} = \frac{1}{32}$$

Prob. that it rains on exactly 3 days in a 5-day period.

$$= {}^5C_3 \times \frac{1}{32} = {}^5C_2 \times \frac{1}{32} = \frac{10}{32} = \frac{5}{16}.$$

11. Ans. (b)

Required probability

$$= {}^3C_1(0.4)(0.6)^2 + {}^3C_2(0.4)^2(0.6) + {}^3C_3(0.4)^3$$

$$= 3(0.144) + 3(0.096) + 1(0.064) = 0.784$$

12. Ans. (a)

13. Ans. (d)

Two cards can be drawn from a pack of 52 playing cards in ${}^{52}C_2$ ways,

$$\text{i.e. } \frac{52 \times 51}{2} = 1326 \text{ ways.}$$

The event that two kings appear in a single draw can appear in 4C_2 ways, i.e. 6 ways.

∴ The probability that the two cards drawn from a pack of 52 cards are kings

$$= \frac{6}{1326} = \frac{1}{221}.$$

14. Ans. (a)

Probability of getting 2 tails + Prob. of getting 1 tail + Prob. of getting no tail

$$= {}^8C_2 \times \frac{1}{256} + {}^8C_1 \times \frac{1}{256} + {}^8C_0 \times \frac{1}{256}$$

$$= \frac{37}{256}.$$

15. Ans. (c)

Required probability

$$= \frac{60}{100} \times \frac{40}{99} + \frac{40}{100} \times \frac{60}{99} = \frac{4800}{100 \times 99} = \frac{16}{33}.$$

□□□□

The chapter of Geometry and mensuration have had their share in various competition Exam. For doing well in questions based on this topic, student should be familiar with the very basics of various two dimensional and solid figures.

To grasp easily the given topic of Geometry and mensuration, we have divided the theory in five parts.

- Angles, Parallel lines & Transverse.
- Triangles and Quadrilaterals
- Mensuration and Solid Geometry
- Circles and its properties
- Coordinate Geometry and Trigonometry

Angles, Parallel Lines and Transverse

When two lines meet at common point they form angle.

Types

1. Acute angle → Angle less than 90°

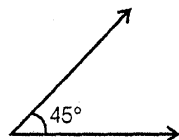

2. Obtuse Angle → Angle more than 90° but less than 180° .

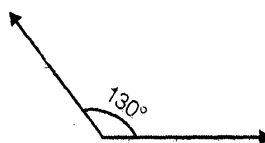

3. Right Angle → Angle equal to 90°

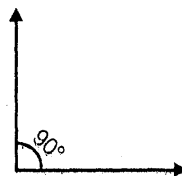

4. Supplementary angle → when sum of two angles is equal to 180° then angles are said to be supplementary

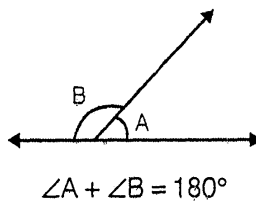

5. Complementary Angle → when sum of two angles is equal to 90° then angles are said to be complementary.

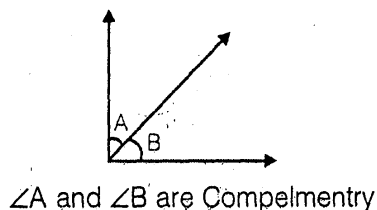

Parallel Lines: Two straight lines are parallel if they lie on the same plane and do not intersect however far produced.

Transversal: It is a straight line that intersect two parallel lines. When a transversal intersect two parallel lines then

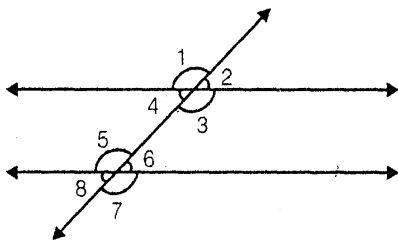

1. Corresponding angle are equal, (that is: for figure above)

$$\angle 1 = \angle 5; \angle 2 = \angle 6, \angle 4 = \angle 8, \angle 3 = \angle 7$$

2. Alternate interior angles are equal, (that is - for above figure)

$$\angle 4 = \angle 6; \angle 5 = \angle 3$$

3. Alternate exterior angles are equal, that is

$$\angle 2 = \angle 8; \angle 1 = \angle 7$$

4. Interior angles on the same side of transversal add upto 180° , that is

$$\angle 4 + \angle 5 = \angle 3 + \angle 6 = 180^\circ$$

Polygons

Polygons are plane figure formed by a closed series of straight segments Examples: Triangles, Rectangles, Pentagon etc.

There are two types of Polygon

1. Regular Polygons: Polygons with all the sides and angles equal.
 2. Irregular Polygons: Polygons in which all the sides or angles are not of same measure.
- Sum of all angles of a polygon with n sides = $(n - 2) 180^\circ$

- Sum of all exterior angles = 360°

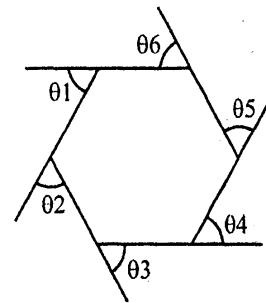

In the figure

$$\theta 1 + \theta 2 + \theta 3 + \theta 4 + \theta 5 + \theta 6 = 360^\circ$$

Triangles

A triangle is a polygon having three sides. Sum of all the angles of a triangle is equal to 180°

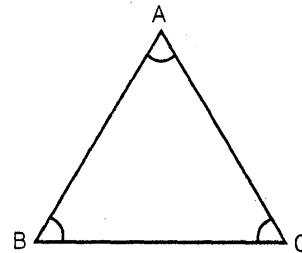

$$\angle A + \angle B + \angle C = 180^\circ$$

Types:

1. Acute angle triangle: Triangles having all three angles less than 90°

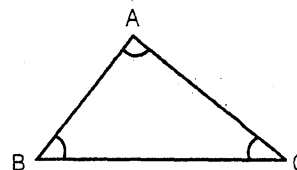

ΔABC is Acute angle triangle

2. Obtuse angle triangle: Triangle with one of the angle obtuse, i.e. more than 90° .

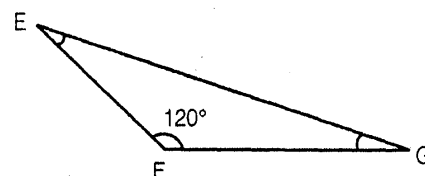

ΔEFG is obtuse angle triangle.

3. **Right angle triangle:** Triangle with one of the angle equal to 90°

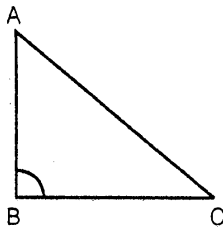

4. **Equilateral triangle:** Triangle in which all sides are equal. All the angles are also equal, and is equal to 60°

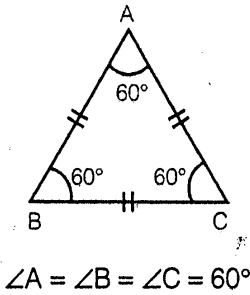

5. **Isoscles triangle:** Triangle with two of its sides equal and consequently the angles, opposite the equal sides are also equal.

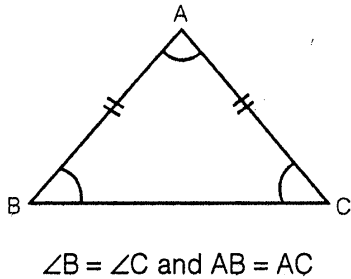

Properties of Triangles

- Sum of the lengths of any two sides of a triangle has to be always greater than the third side.
- Difference between the lengths of any two sides of a triangle has to be always lesser than the third side.
- Side opposite to the greatest angle will be the greatest and the side opposite to the smallest angle will be smallest.

Area of Triangle

1. $\text{Area} = \frac{1}{2} \text{base} \times \text{height}$

$$\Delta = \frac{1}{2} \times b \times h$$

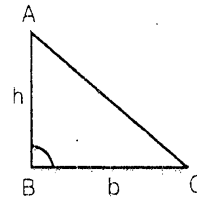

2. $\text{Area} = \sqrt{S(S-a)(S-b)(S-c)}$

This is called Hero's formula

Where $S = \frac{a+b+c}{2}$, and a, b and c are

the sides of triangle.

3. $\text{Area} = \frac{1}{2} \times \text{product of two sides}$
 $\times \text{sine of the included angle}$

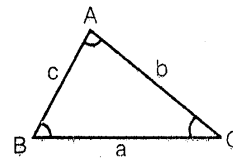

$$\text{Area of } \Delta ABC = \frac{1}{2} ac \sin B$$

$$= \frac{1}{2} ab \sin C = \frac{1}{2} bc \sin A$$

Where a, b, c denotes sides BC, CA and AB and A, B and C denotes angle $\angle A$, $\angle B$ and $\angle C$ respectively.

Equilateral Triangles

1. Altitude $h = \frac{a\sqrt{3}}{2}$

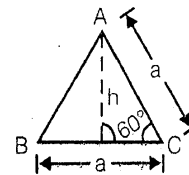

2. $\text{Area} = \frac{1}{2} (\text{base}) \times \text{height}$

$$= \frac{1}{2} \times a \times \frac{a\sqrt{3}}{2} = \frac{\sqrt{3}}{4} a^2$$

Isosceles Triangles

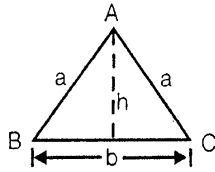

1. Altitude $h = \frac{1}{2} \times \sqrt{4a^2 - b^2}$,
2. Area = $\frac{1}{2} \times \text{base} \times \text{height}$
 $= \frac{b}{4} \sqrt{4a^2 - b^2} = \frac{b}{4} \sqrt{4a^2 - b^2}$

Right Angled Triangle

Pythagoras Theorem

According to Pythagoras Theorem Square of hypotenuse of a right angled triangle is equal to sum of squares of altitude and base.

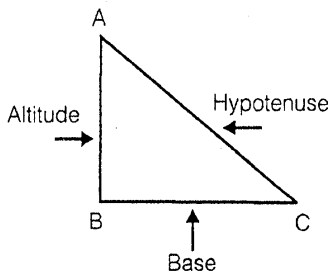

$$(AC)^2 = (AB)^2 + (BC)^2$$

Some Basic Pythagorean Triplet

- 3, 4, 5 → $3^2 + 4^2 = 5^2$
- 5, 12, 13 → $5^2 + 12^2 = 13^2$
- 7, 24, 25 → $7^2 + 24^2 = 25^2$
- 8, 15, 17 → $8^2 + 15^2 = 17^2$
- 9, 40, 41 → $9^2 + 40^2 = 41^2$
- 11, 60, 61 → $11^2 + 60^2 = 61^2$
- 12, 35, 37 → $12^2 + 35^2 = 37^2$
- 16, 63, 65 → $16^2 + 63^2 = 65^2$

- 20, 21, 29 → $20^2 + 21^2 = 29^2$
- 28, 45, 53 → $28^2 + 45^2 = 53^2$

These triplet are very important since large number of questions are based on them. Remembering these triplets can save lots of valuable time.

Multiplying or Dividing the triplet by any real number gives new triplets. For example

- 3, 4, 5 will give 6, 8, 10
- 9, 12, 15 and
- 12, 16, 20 etc.

Quadrilaterals

Polygons having four sides are called quadrilaterals. Sum of all internal angles in a quadrilateral is equal to 360° .

Types of Quadrilaterals

1. Parallelogram

A quadrilateral in which opposite sides are parallel (as shown in figure)

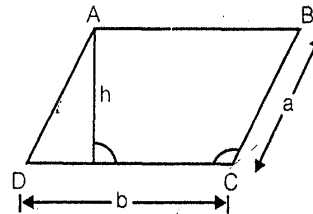

- Area = Base x height = bh
- Area = Product of any two adjacent sides x sine of the included angle i.e. $ab \sin C$ (here $\angle C$ is $\angle DCB$)
- Perimeter = $2(a + b)$ where a and b are two adjacent sides.

2. Rectangles

A rectangle is a parallelogram in which all angles are equal to 90°

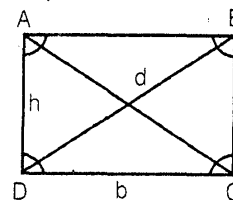

(a) Area = Base \times height = $b \times h$

(b) Diagonal (d) = $\sqrt{h^2 + b^2}$

3. Rhombus

A Parallelogram having all sides equal is a rhombus

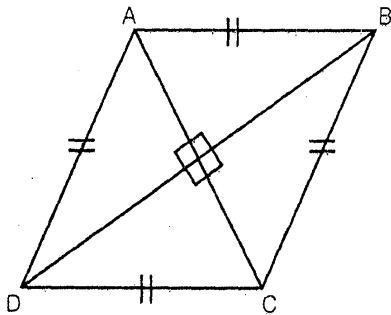

Area $\rightarrow \frac{1}{2} \times$ product of diagonal

\times sine of angle between them

- In rhombus diagonals bisect each other at right angle

4. Square

Square is a parallelogram in which all the sides are equal and also all the angles are equal to 90°

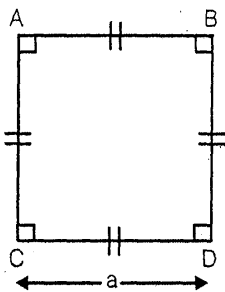

Area = (Side)² = a^2

= $\frac{1}{2}(\text{diagonal})^2 = \frac{1}{2}d^2$

Diagonal = $\sqrt{2}a$

Perimeter = $4a$

- In square diagonal bisect each other at 90° , and also diagonals are equal to each other.

5. Trapezium

A quadrilateral in which only two sides are parallel to each other is called trapezium.

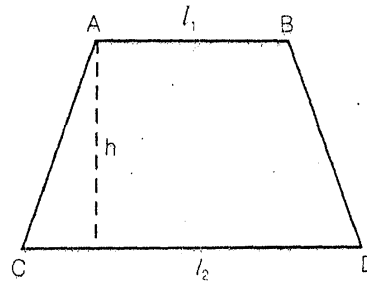

Area = $\frac{1}{2} \times$ sum of parallel sides
 \times distance between them

= $\frac{1}{2} \times (l_1 + l_2) \times h$

Mensuration & Solid Geometry

Mensuration is a branch of science which deals with measurements especially of surface area, Volume, curved surface area etc of plane and solid figures. So far we have discussed the plane figure like triangles and quadrilateral we, now, will proceed on solid figures.

1. Cube

Cube is a three dimensional box in which all the three side that is length breadth & height are equal.

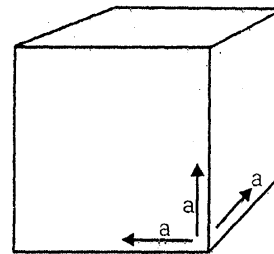

Volume of a cube = (side)³ = a^3

Total surface area of a cube

= $6 \times (\text{side})^2 = 6a^2$

Surface area of four walls

= $4 \times (\text{side})^2 = 4a^2$

2. Cuboid

Cuboid is a solid figure in which length breadth & heights are not equal.

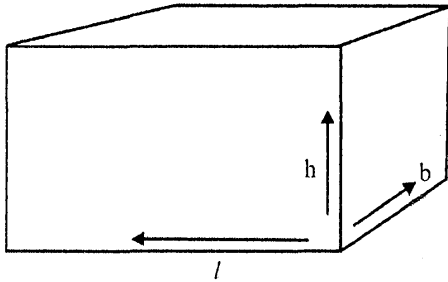

This is the most common figure.

Volume = length \times breadth \times height

$$= l \times b \times h$$

Total surface area = $2(lb + bh + hl)$

Area of the four walls of cuboid shaped

$$\text{room} = 2(bh + hl)$$

$$\text{Diagonal of cuboid} = \sqrt{l^2 + b^2 + h^2}$$

$$\text{Diagonal of cube} = \sqrt{3 \times d}$$

3. Cylinder

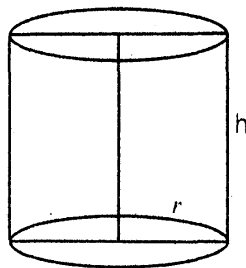

Volume of cylinder

$$= \pi \times (\text{radius})^2 \times \text{height} = \pi r^2 h$$

Curved surface area

$$= 2 \times \pi \times (\text{radius}) \times \text{height} = 2\pi rh$$

Total surface area = Curved surface area + Area of upper & lower circles.

$$= 2\pi rh + 2\pi r^2 = 2\pi r(r + h)$$

4. Cone

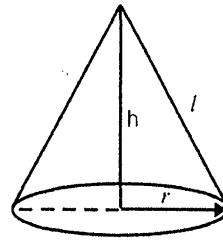

Volume of a cone

$$= \frac{1}{3} \times \pi \times (\text{radius})^2 \times (\text{height}) = \frac{1}{3} \pi r^2 h$$

Curved surface area = $\pi r l$

(where l is lateral height which is equal to

$$l = \sqrt{r^2 + h^2})$$

$$\text{Total surface Area} = \pi r l + \pi r^2$$

5. Sphere

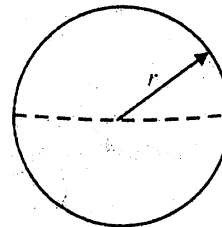

$$\text{Volume of sphere} = \frac{4}{3} \pi r^3$$

$$\text{Total surface Area} = 4\pi r^2$$

6. Hemisphere

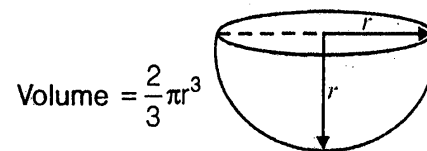

$$\text{Volume} = \frac{2}{3} \pi r^3$$

$$\text{Curved Surface Area} = 2\pi r^2$$

$$\text{Total Surface Area} = 3\pi r^2$$

Trigonometry

This is one of the most important part of geometry. Questions of trigonometry are based mainly only its basic concept of sine, cosine & tangents, at the same time problem on height & distance are also very common.

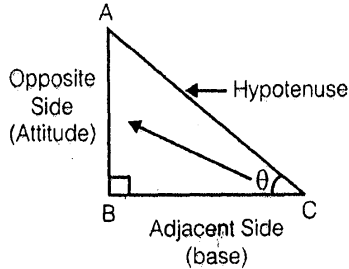

$$\sin \theta = \frac{\text{Opposite side}}{\text{Hypotenuse}}$$

$$\operatorname{cosec} \theta = \frac{\text{Hypotenuse}}{\text{Opposite side}}$$

$$\cos \theta = \frac{\text{Adjacent side}}{\text{Hypotenuse}}$$

$$\sec \theta = \frac{1}{\cos \theta} = \frac{\text{Hypotenuse}}{\text{Adjacent side}}$$

$$\tan \theta = \frac{\text{Opposite side}}{\text{Adjacent side}}$$

$$\cot \theta = \frac{1}{\tan \theta} = \frac{\text{Adjacent side}}{\text{Opposite side}}$$

Calculation of sine, cosine & tangent of different angles.

1. for 30° & 60°

Construct equilateral triangle of side a.

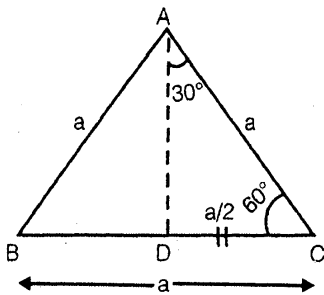

Height $h = \frac{\sqrt{3}a}{2}$ is triangle (ΔADC)

$$\sin 60^\circ = \frac{\frac{\sqrt{3}}{2}a}{a} = \frac{\sqrt{3}}{2}$$

$$\cos 60^\circ = \frac{\frac{a}{2}}{a} = \frac{1}{2}$$

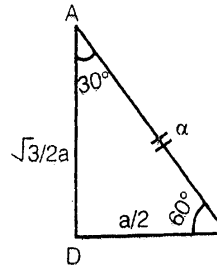

$$\tan 60^\circ = \frac{\frac{\sqrt{3}}{2}a}{\frac{a}{2}} = \sqrt{3}$$

2. for 30°

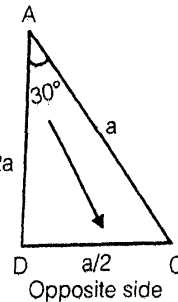

In Triangle ADC $\sqrt{3}/2a$

$$\sin 30^\circ = \frac{\frac{a}{2}}{a} = \frac{1}{2}$$

$$\cos 30^\circ = \frac{\frac{\sqrt{3}}{2}a}{a} = \frac{\sqrt{3}}{2}$$

$$\tan 30^\circ = \frac{\frac{a}{2}}{\frac{\sqrt{3}}{2}a} = \frac{1}{\sqrt{3}}$$

3. For 45°

Construct a right angled triangle in which one angle is equal to 45°.

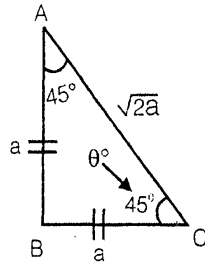

$$\sin 45^\circ = \frac{a}{\sqrt{2} a} = \frac{1}{\sqrt{2}}$$

$$\cos 45^\circ = \frac{a}{\sqrt{2} a} = \frac{1}{\sqrt{2}}$$

$$\tan 45^\circ = \frac{a}{a} = 1$$

4. For 90°

In the above figure to make angle equal to 90° side AC should become very closer to AB. Its closeness of AC to AB is upto such an extent that AC overlaps (coincides) AB.

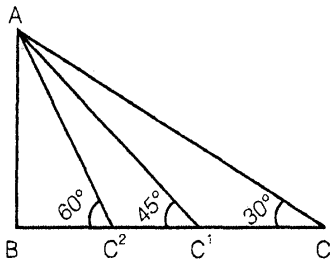

in case of 90° Hypotenuse AC=AB (AB is opposite side)

$$\sin 90^\circ = \frac{AB}{AC} = 1$$

$$\cos 90^\circ = \frac{AB}{AC} = 0 (\because BC = 0)$$

$$\tan 90^\circ = \frac{AB}{BC} = \infty (\because BC = 0)$$

5. For 0°

In the above figure angle ∠A will be equal to 0° if angle ∠C is equal to 90°

So, in 0°

AC is Hypotenuse = AB(Adjacent side) and opposite side BC=0

$$\text{so, } \sin 0^\circ = \frac{BC}{AC} = 0$$

$$\cos 0^\circ = \frac{AB}{AC} = 1$$

$$\tan 0^\circ = \frac{BC}{AB} = 0$$

Trigonometric Table

SN.	Angle(θ)	sin θ	cos θ	tan θ	cosec θ	sec θ	cot θ
1.	0°	0	1	0	∞	1	∞
2.	30°	1/2	√3/2	1/√3	2	2/√3	√3
3.	45°	1/√2	1/√2	1	√2	√2	1
4.	60°	√3/2	1/2	√3	2/√3	2	1/√3
5.	90°	1	0	∞	1	∞	0

Angle of elevation & angle of Depression

1. Angle of Elevation: It is that angle which our eye makes with that of horizontal line of sight when observing objects at height above the line of sight.

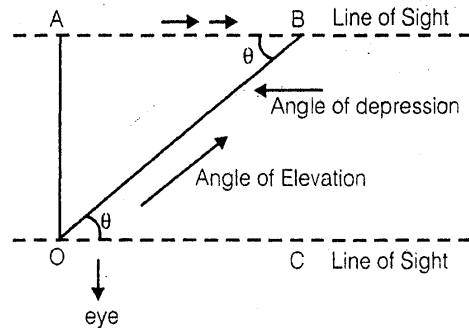

In the above figure ∠BOC of Elevation

2. **Angle of Depression:** It is that angle which our eye makes with that of line of sight while observing object below it ex:- when pilot of an aircraft observe the base station angle formed in the angle of depression here $\angle ABO$ is angle of depression

Note: Angle of Elevation is always equal to angle of depression.

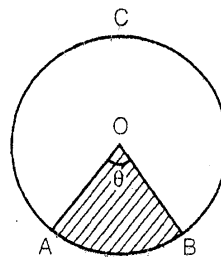

$$\text{Area of Sector} = \pi r^2 \times \frac{\theta}{360^\circ}$$

- in the above figure perimeter of sector

$$\text{is equal to} = 2\pi r \times \frac{\theta}{360^\circ} + 2r$$

Circles and its properties

Circle

A circle is a set of all those points in a plane, each one of which is at given constant distance from a fixed point in the plane

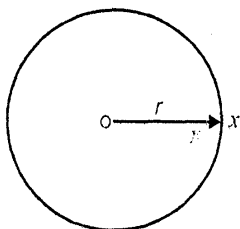

The fixed point is called the centre and the given constant distance is called the radius of the circle.

- Area = πr^2
- Circumference = $2\pi r$
- Length of Arc AB = $\frac{\theta}{360} \times 2\pi r$

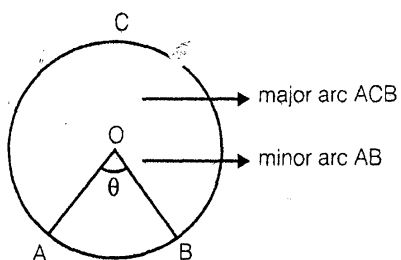

- Sector of a Circle:** It is a part of the area of a circle between two radii.

Properties

- The perpendicular from the centre of a circle to a chord bisect the chord

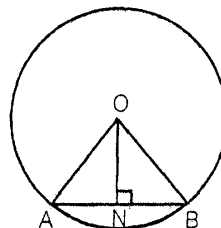

If $ON \perp AB$, then $AN = NB$

- Equal chord of a circle subtend equal angle at the centre

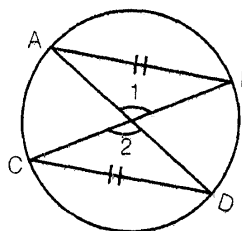

If $AB = CD$ then $\angle 1 = \angle 2$

- Equal chords of a circle are equidistance from the centre

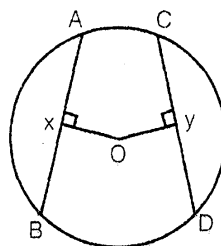

If the chord AB and CD of a circle are equal and if $OX \perp CD$ then

$$OX = OY$$

4. The angle subtended by an arc of a circle at the centre is double the angle subtended by it at any point on the remaining part of the circle.

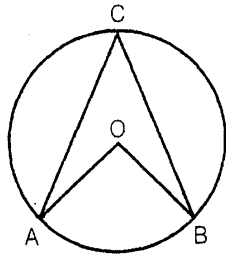

If fig: $\angle AOB = 2 \times \angle ACB$

5. Angle in the same segment of a circle are equal

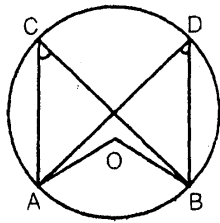

In fig $\angle AOB = 2\angle ACB$
 also $\angle AOB = 2\angle ADB$
 So $\angle ACB = \angle ADB$

6. The angle in a semi circle is a right angle

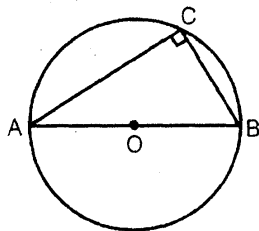

In the figure above $\angle ACB = 90^\circ$

7. The opposite pairs of angles of a cyclic quadrilateral is supplementary to each other

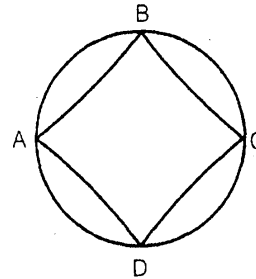

In the figure $\angle A + \angle C = 180^\circ$ & also
 $\angle B + \angle D = 180^\circ$

Tangents and Secants

Tangent touch the circle at one point, while secant touch the circle at two points.

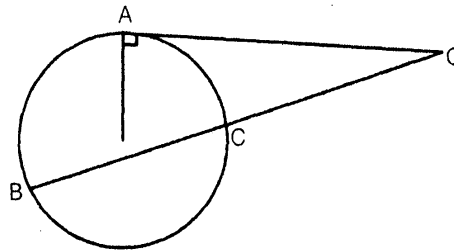

In the figure AO is tangent while BCO is a secant.

- A tangent at any point of a circle is perpendicular to the radius through the point of contact
- The length of two tangents drawn from an external point to a circle are equal

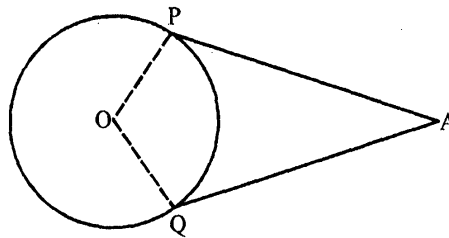

In the above figure $AP = AQ$

- If two chords AB and CD intersect internally or externally at a point P then
 $PA \times PB = PC \times PD$

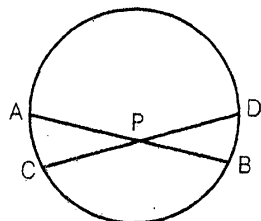

Fig (i)

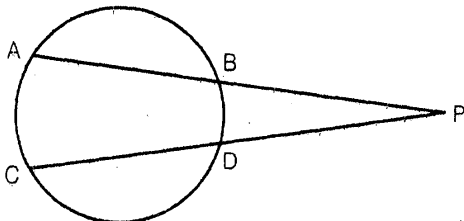
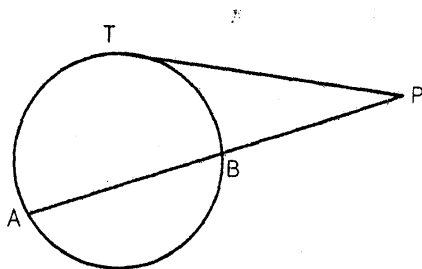
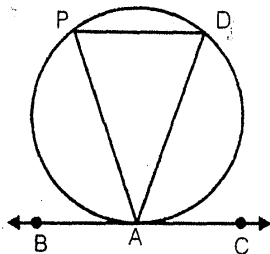

Fig (ii)

- If PAB is a secant to a circle intersecting the circle at A and B, and PT is tangent segment then $PA \times PB = PT^2$
(Popularly known as Tangent -Secant theorem)



- Alternate segment Theorem



In the figure above, if BAC is the tangent at A to a circle and if AD is any chord then

$$\angle DAC = \angle APD \text{ and}$$

$$\angle PAB = \angle PDA$$

(Angles in alternate segment)

- If a circle touches all the four sides of a quadrilateral then the sum of opposite pair sides are equal

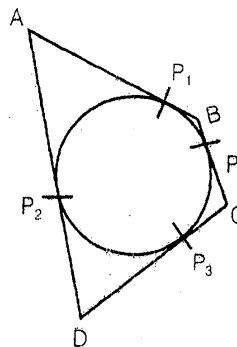

If ABCD is a circumscribed quadrilateral, then $AB + CD = AD + BC$.

TRIGONOMETRY

Height and Distance

Solved Examples

1. The ratio of the length of a rod and its shadow is $1 : \sqrt{3}$. Find the angle of elevation of the sun.

Solution: Let AB be the rod and AC be its shadow.

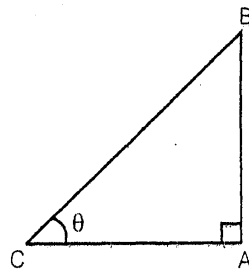

$$\angle ACB = \theta \text{ Let } AB = x,$$

$$\text{Then, } AC = \sqrt{3}x$$

$$\therefore \tan \theta = \frac{AB}{AC} = \frac{x}{\sqrt{3}x} = \frac{1}{\sqrt{3}} = 30^\circ$$

2. A tower stands at the end of a straight road. The angles of elevation of the top of the tower from two points on the road 500 m apart are 45° and 60° , respectively. Find the height of the tower.

Solution: $CD = AB(\cot 45^\circ - \cot 60^\circ)$

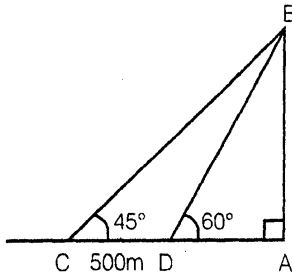

$$AB = \frac{CD}{\cot 45^\circ - \cot 60^\circ}$$

$$AB = \frac{CD}{\cot 45^\circ - \cot 60^\circ}$$

$$= \frac{500}{1 - \frac{1}{\sqrt{3}}} = \frac{500\sqrt{3}}{\sqrt{3} - 1}$$

3. From the top of a cliff 25m high the angle of a tower is found to be equal to the angle of depression of the foot of the tower. Find the height of the tower.

Solution: Let AB be the cliff and CD be the tower.

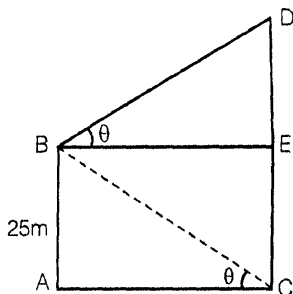

From B, draw $BE \perp CD$

$$\frac{DE}{BE} = \tan \theta \text{ and } \frac{AB}{AC} = \tan \theta$$

$$\therefore \frac{DE}{BE} = \frac{AB}{AC}$$

$$\therefore DE = AB \quad (\because BE = AC)$$

$$\therefore CD = CE + DE = AB + AB = 2AB = 50 \text{ m}$$

4. Angle of depression from the top of a light house of two boats are 45° and 30° due east which are 60m apart. Find the height of the light house.

Solution: Let the boats be at P, Q,

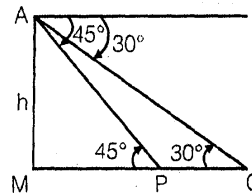

So that $PQ = 60\text{m}$.

Let MA be the light house.

Let $h = MA$

$$\text{Then, } \therefore \frac{h}{MP} = \tan 45^\circ = 1,$$

$$\therefore h = MP$$

$$\text{Again, } \frac{h}{MP + 60} = \tan 30^\circ = \frac{1}{\sqrt{3}}$$

$$\therefore MP + 60 = \sqrt{3}h \text{ or } h + 60 = \sqrt{3}h$$

$$\therefore (\sqrt{3} - 1)h = 60$$

$$\therefore h = \frac{60}{\sqrt{3} - 1} = \frac{60(\sqrt{3} + 1)}{2}$$

$$= 30(\sqrt{3} + 1)\text{m}$$

5. The angle of elevation of the top of a tower at a point G on the ground is 30° . On Walking 20m forwards the tower the angle of elevation becomes 60° . The height of the tower is equal to.

(a) $\frac{10}{\sqrt{3}}$ m (b) $20\sqrt{3}$ m

(c) $\frac{20}{\sqrt{3}}$ m (d) $10\sqrt{3}$ m

Solution: (d)

Let AB = h be the height of the tower.

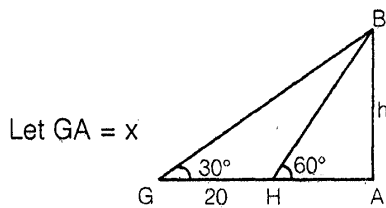

Then, $\frac{h}{x} = \tan 30^\circ = \frac{1}{\sqrt{3}}$

$\therefore h = \frac{x}{\sqrt{3}}$

Also, $\frac{h}{x-20} = \tan 60^\circ = \sqrt{3}$

$\therefore h = \sqrt{3}(x-20)$

$\therefore \frac{x}{\sqrt{3}} = \sqrt{3}(x-20)$

$x = 3(x-20) = 3x - 60$

$\therefore 2x = 60 \quad \therefore x = 30$

$\therefore h = \frac{30}{\sqrt{3}} = 10\sqrt{3}$ m.

□□□□

Circles and its properties

Solved Examples

1. Two isoscles triangles have equal angles and their areas are in the ratio 16:25. Find the ratio of their corresponding heights.

(a) $\frac{4}{5}$ (b) $\frac{5}{4}$

(c) $\frac{2}{3}$ (d) $\frac{5}{6}$

Solution: When triangle have euqal angles the ratio of the Areas & Heights can be given as

$$\frac{\text{Area } \Delta 1}{\text{Area } \Delta 2} = \frac{(\text{Height } 1)^2}{(\text{Height } 2)^2}$$

$$\frac{16}{25} = \frac{(H_1)^2}{(H_2)^2}$$

So $\frac{H_1}{H_2} = \frac{4}{5}$ & Ans.(a)

2. The radius of a circle is 13 cm and the length of one of its chord is 24 cm. Find the distance of the chord from centre.

- (a) 10 cm (b) 8 cm
(c) 5cm (d) 5.5 cm

Solution:

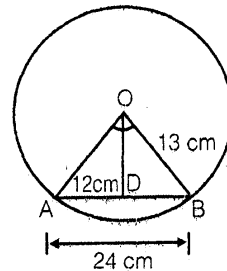

$$(OB)^2 = (OD)^2 + (DB)^2$$

$$13^2 = (OD)^2 + (12)^2$$

$$(OD)^2 = 13^2 - 12^2 = 25 \text{ cm}^2$$

$$OD = 5 \text{ cm}$$

Ans: (c)

3. In figure if O is the centre of circle, find $\angle x$

- (a) 35° (b) 30°
(c) 45° (d) 50°

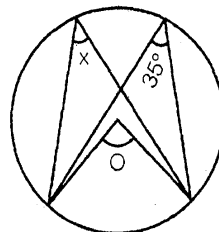

Solution: Since angle on the same segment of circle are equal so $\angle x = 35^\circ$ Ans(a)

4. Find the value of $\angle x$ in the given figure, 'O' is centre

- (a) 120° (b) 130°
 (c) 100° (d) 150°

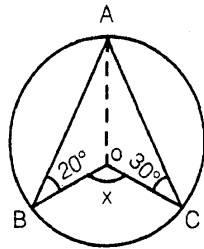

Solution: $\angle OAB = \angle OBA$

$\therefore AO = OB$ being radius of circle

$\angle OAB = 20^\circ$

Similarly $\angle OAC = \angle OCA$, $\angle OAC = 30^\circ$

Now $\angle BAC = 20 + 30 = 50^\circ$

So $\angle BOC = \angle x = 2\angle BAC = \angle x = 100^\circ$

Ans (c)

5. Find the value of x in the figure, if it is given that AC and BD are diameters of the circle.

- (a) 60° (b) 45°
 (c) 15° (d) 30°

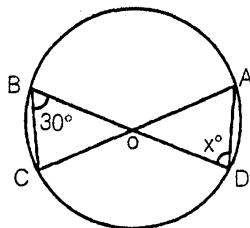

Solution: join A&B and C&D

Now $\angle BAD = 90^\circ$

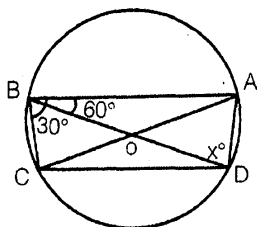

\therefore Angle of Semicircle

So in $\triangle BAD$

$\angle DBA = 60^\circ$ $\angle BAD = 90^\circ$

So $\angle ADB = \angle x = 30^\circ$ Ans. (d)

6. Find the value of x in the given figure

- (a) 2.2 cm (b) 1.6 cm
 (c) 3 cm (d) 2.6 cm

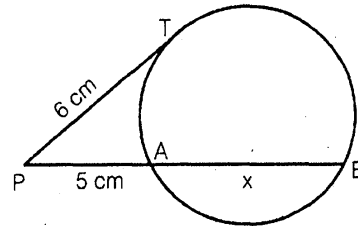

Solution: According to Tangent - Secant Theorem

$PT^2 = PA \times PB$

$6^2 = 5 \times (5 + x)$, $11 = 5x$

$x = \frac{11}{5} = 2.2$ Ans. (a)

7. Find the value of Z in the given figure.

- (a) 16 cm (b) 9 cm
 (c) 12 cm (d) 7 cm

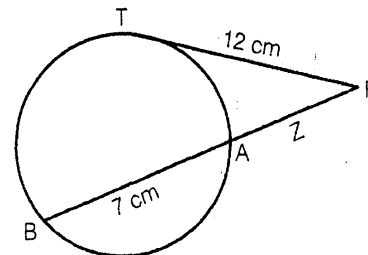

Solution: $PT^2 = PA \times PB$

$12^2 = Z \times (Z + 7)$

$144 = Z^2 + 7Z$

$Z^2 + 7Z - 144 = 0$, $(Z + 16)(Z - 9) = 0$

$Z = 9$, $Z = -16$ (Not possible)

Hence $Z = 9$. Ans (b)

8. Find the value of x in the given figure

- (a) 13 cm (b) 12 cm
 (c) 16 cm (d) 15 cm

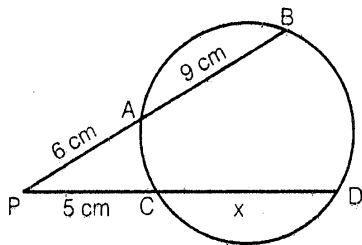

Solution: $\therefore PA \times PB = PC \times PD$

So, $6 \times 15 = 5 \times (5 + x)$

$90 = 25 + 5x$, $65 = 5x$, $13 = x$ Ans. (a)

9. In the given figure AB is the diameter of circle and $\angle PAB = 25^\circ$. Find $\angle TPA$

- (a) 50° (b) 65°
 (c) 70° (d) 45°

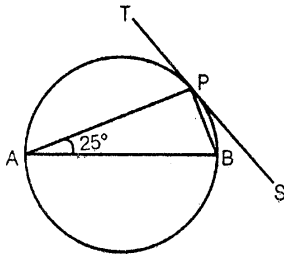

Solution: $\angle APB = 90^\circ$ (\because Angle of a semicircle is a right angle)

Also $\angle ABP = 65^\circ$

[$\because \Delta APB \angle A = 25^\circ \angle APB = 90^\circ$

So $\angle ABP = 65^\circ$]

Now $\angle TPA = \angle ABP = 65^\circ$

[\because Angles in alternate segments are equal]

hence

Ans (b)

10. In the given figure find $\angle ADB$

- (a) 144° (b) 132°
 (c) 72° (d) 104°

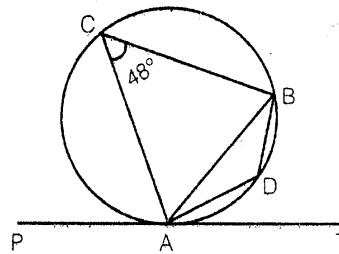

Solution: In the given figure ADBC is a cyclic quadrilateral

So $\angle C + \angle D = 180^\circ$

$\angle D = \angle ADB = 180^\circ - \angle C$

$\angle ADB = 180^\circ - 48^\circ = 132^\circ$ Ans (b)

11. In the figure, if it is given that O is the centre of the circle and $\angle AOC = 140^\circ$ Find $\angle ABC$

- (a) 110° (b) 130°
 (c) 150° (d) 105°

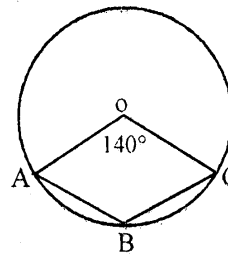

Solution: Join AD & CD

Now $\angle ADC = \frac{1}{2} \angle AOC$

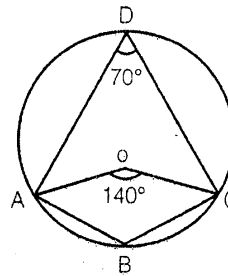

$\angle ADC = 70^\circ$

In the given figure ABCD is a cyclic quadrilateral So

$\angle ADC + \angle ABC = 180^\circ$

$\angle ABC = 180^\circ - \angle ADC$

($\because \angle ADC = 70^\circ$) = 110° Ans (a)

□□□□

Triangles & Quadrilaterals



Practice Exercise: I

- The area of a triangle whose sides are 15m, 16m and 17m
 - $24\sqrt{4}$ sq m
 - $24\sqrt{3}$ sq m
 - $24\sqrt{21}$ sq m
 - None of these
- The area of a triangular lawn is 1600 Sq m. If one side is 64 m long and the other two sides are equal in length, the length of each equal side is
 - 60.37 m
 - 59.36 m
 - 60.36 cm
 - None of these
- The sides of a triangle are in the ratio 3:4:5. If its perimeter is 36 cm, area of the triangle is
 - 57 sq cm
 - 54 sq cm
 - 56.5 sq cm
 - None of these
- A ladder is placed so as to reach a window 63 cm high. The ladder is then turned over to the opposite side of the street and is found to reach a point 56 cm high. If the ladder is 65 cm long, the width of the street is
 - 59 cm
 - 39 cm
 - 49 cm
 - None of these
- If the area of a triangle is 150 sq m and base : height is 3:4, find its height,
 - 25 m
 - 35 m
 - 20 m
 - None of these
- Two sides of a triangular field are 85 m and 154, respectively, and its perimeter is 324m. The cost of ploughing the field at the rate of Rs. 10 per sq m is
 - Rs. 27720
 - Rs. 37620
 - Rs. 26750
 - None of these
- If the perimeter of an equilateral triangle is 12m, find its area.
 - $3\sqrt{4}$ m
 - $4\sqrt{3}$ m
 - $5\sqrt{3}$ m
 - None of these
- Find the area of an isosceles right-angled triangle whose hypotenuse is 8 cm.
 - 32 sq m
 - 24 sq m
 - 16 sq m
 - None of these
- If all sides of a triangle are increased by 200% the area of the triangle will increase by
 - 400%
 - 600%
 - 800%
 - None of these
- The two adjacent sides of a parallelogram are 60 m and 40 m and one of the diagonals is 80 m long. The area of the parallelogram is
 - $600\sqrt{15}$ sq m
 - $800\sqrt{15}$ sq m
 - $700\sqrt{15}$ sq m
 - None of these
- One side of a parallelogram is 10 m and the corresponding altitude is 7 m. The area of the parallelogram is
 - 70 sq m
 - 60 sq m
 - 80 sq m
 - None of these
- In a quadrilateral $ABCD$, the sides AB , BC , CD , DA measure 20 m, 13m, 17m and 10m, respectively and the diagonal AC is 21m. The area of the quadrilateral is
 - 210 sq m
 - 220 sq m
 - 240 sq m
 - None of these
- In a parallelogram, the length of adjacent sides are 12 cm and 14 cm, respectively. If the length of one diagonal is 16 cm, find the length of the other diagonal.
 - 24.8 cm
 - 20.6 cm
 - 22.4 cm
 - None of these

14. The perimeter of a circle is equal to that of a square. Compare their areas:
 (a) 14 : 11 (b) 25 : 12
 (c) 24 : 7 (d) 22 : 7
15. The wheel of a scooter has diameter 70 cm. How many revolutions per minute must the wheel make so that the speed of the scooter is kept 66 km per hour?
 (a) 400 (b) 600
 (c) 500 (d) 800
16. The area of a trapezium is 2500 sq m. One of its parallel sides is 75m. If the distance between the two parallel sides is 40 m, find the other parallel side.
 (a) 20 m (b) 30 m
 (c) 40 m (d) 50 m
17. If the ratio of the areas of two squares is 9:1, the ratio of their perimeters is
 (a) 9 : 1 (b) 3 : 4
 (c) 3 : 1 (d) 1 : 3
18. A rope by which a calf is tied is increased from 12m to 23m. How much additional grassy ground shall it graze?
 (a) 1120 m^2 (b) 1250 m^2
 (c) 1210 m^2 (d) 1200 m^2
19. The length of a rectangular field is twice its breadth. If the rent of the field at Rs. 3500 a hectare is Rs. 28000, find the cost of surrounding it with fence at Rs. 5 per metre.
 (a) Rs. 6000 (b) Rs. 7000
 (c) Rs. 6500 (d) Rs. 8000
20. The area of a sector of a circle of radius 5 cm, formed by an arc of length 3.5 cms, is
 (a) 35 cm^2 (b) 17.5 cm^2
 (c) 8.75 cm^2 (d) 55 cm^2
21. A rectangular sheet of cardboard is of $4\text{ cm} \times 2\text{ cm}$. If a circle of greatest possible area is cut from it, then the area of remaining portion is
 (a) $(2 - \pi)\text{ cm}^2$ (b) $(4 - \pi)\text{ cm}^2$
 (c) $(8 - \pi)\text{ cm}^2$ (d) $(16 - \pi)\text{ cm}^2$
22. If the area of a square is equal to the area of a rectangle 6.4m long and 2.5 m wide, then each side of the square measures
 (a) 8 m (b) 5.4 m
 (c) 3.8 m (d) 4 m
23. A rectangular carpet has an area of 120 sq m and a perimeter of 46m. The length of its diagonal is
 (a) 15 m (b) 16 m
 (c) 17 m (d) 20 m
24. A piece of wire 132 cm long is bent successively in the shape of an equilateral triangle, a square, a regular hexagon, and a circle. Then, which has the largest surface area?
 (a) equilateral triangle
 (b) Square
 (c) circle
 (d) regular hexagon
25. The radius of the wheel of a vehicle is 70 cm. The wheel makes 10 revolutions in 5 seconds. The speed of the vehicle is
 (a) 29.46 km/hr (b) 31.68 km/hr
 (c) 36.25 km/hr (d) 32.72 km/hr
26. The area of a big rectangle is equal to $1/6^{\text{th}}$ of a small rectangle. If the length of the big rectangle is equal to the length of the small rectangle and the width of big rectangle is 2m, what is the width of a small rectangle?
 (a) $1/3\text{ m}$ (b) 1 m
 (c) 2 m (d) None of these
 (e) Cannot be determined
27. If a regular hexagon is inscribed in a circle of radius r , then its perimeter is
 (a) $3r$ (b) $6r$
 (c) $9r$ (d) $12r$

28. A circle road runs around a circular garden. If the difference between the circumference of the outer circle and the inner circle is 44m, find the width of the road.

- (a) 4 m (b) 7 m
(c) 3.5 m (d) 7.5 m

29. A garden is 24m long and 14m wide. There is a path 1m wide outside the garden along its sides. If the path is to be constructed with square marble tiles 20cm × 20 cm find the number of tiles required to cover the path.

- (a) 1800 (b) 200
(c) 2000 (d) 2150

30. The area of the circle inscribed in an equilateral triangle of side 24 cm is

- (a) $24\pi \text{ cm}^2$ (b) $36\pi \text{ cm}^2$
(c) $48\pi \text{ cm}^2$ (d) $18\pi \text{ cm}^2$

Solutions

1. Ans: (c)

Let $a = 15\text{m}$, $b = 16\text{m}$, $c = 17\text{m}$.

Then

$$s = \frac{a+b+c}{2} = \frac{15+16+17}{2} = 24 \text{ m}$$

$$\therefore \text{Area} = \sqrt{s(s-a)(s-b)(s-c)}$$

$$= \sqrt{24(24-15)(24-16)(24-17)}$$

$$= \sqrt{24 \times 9 \times 8 \times 7}$$

$$= \sqrt{12096} = 24\sqrt{21} \text{ sq.m}$$

2. Ans: (b)

Let the length of equal sides be x .

$$\text{Then, } s = \frac{x+x+64}{2} = x+32$$

$$\text{Area} = 1600 \text{ sq m.}$$

$$= \sqrt{(x+32)(x+32-x)(x+32-x)(x+32-64)}$$

$$= \sqrt{(x+32) \times 32 \times 32 \times (x-32)}$$

$$\text{or, } 1600 = 32\sqrt{x^2 - 32^2}$$

$$\Rightarrow \sqrt{x^2 - 32^2} = 50$$

$$\text{or, } x^2 = 32^2 + 50^2 = 1024 + 2500 = 3524$$

$$\therefore x = 59.36 \text{ m}$$

3. Ans. (b)

The sides of the triangle are

$$a = \frac{3}{12} \times 36 = 9 \text{ cm, } b = \frac{4}{12} \times 36 = 12 \text{ cm}$$

$$c = \frac{5}{12} \times 36 = 15 \text{ cm}$$

$$s = \frac{a+b+c}{2} = \frac{36}{2} = 18 \text{ cm}$$

$$\therefore \text{Area} = \sqrt{s(s-a)(s-b)(s-c)}$$

$$= \sqrt{18(18-9)(18-12)(18-15)}$$

$$= \sqrt{18 \times 9 \times 6 \times 3}$$

$$= \sqrt{9^2 \times 2^2 \times 3^2} = 9 \times 2 \times 3$$

$$= 54 \text{ sq cm.}$$

4. Ans. (c)

$$BC = \sqrt{(65)^2 - (63)^2} = 16$$

$$CD = \sqrt{(65)^2 - (56)^2} = 33$$

$$\therefore \text{Width of the street} = 16 + 33 = 49 \text{ cm}$$

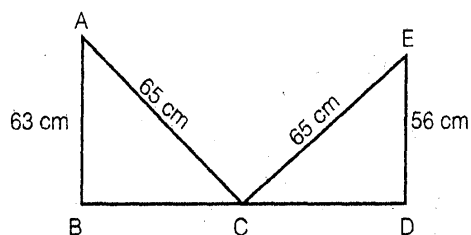

5. Ans. (c)

Let the base be $3x$. Then, the height is $4x$.

$$\text{Given: } \frac{1}{2} \times 3x \times 4x = 150 \Rightarrow x = 5.$$

$$\therefore \text{Base} = 3 \times 5 = 15 \text{ m and} \\ \text{height} = 4 \times 5 = 20 \text{ m}$$

6. Ans. (a)

$$\text{The third side of the triangle} \\ = 324 - (85 + 154) = 85 \text{ m}$$

$$\text{Also, } s = \frac{a+b+c}{2} = \frac{324}{2} = 162.$$

\therefore Area of the triangle

$$= \sqrt{s(s-a)(s-b)(s-c)}$$

$$= \sqrt{162(162-85)(162-85)(162-154)}$$

$$= \sqrt{162 \times 77 \times 77 \times 8} = 2772 \text{ sq m.}$$

$$\therefore \text{The cost of ploughing the field} \\ = 2772 \times 10 = \text{Rs. } 27720$$

7. Ans. (b)

$$3 \times (\text{side}) = 12 \Rightarrow \text{side} = 4 \text{ m.}$$

\therefore Area of equilateral triangle

$$= \frac{\sqrt{3}}{4} (\text{side})^2 = \frac{\sqrt{3}}{4} \times 16 = 4\sqrt{3} \text{ m.}$$

8. Ans. (c)

We have, hypotenuse

$$= \sqrt{2}a = 8 \Rightarrow a = 8/\sqrt{2}.$$

\therefore Area of isosceles right angled triangle

$$= \frac{1}{2} a^2$$

$$= \frac{1}{2} \times \frac{64}{2} = 16 \text{ sq m}$$

9. Ans. (c)

$$\text{Area} = \sqrt{s(s-a)(s-b)(s-c)} = A$$

$$\text{Where } s = \frac{a+b+c}{2} \text{ and}$$

a, b, c are sides of the triangle,

When the sides are increased by 200%, the sides become $3a, 3b$ and $3c$.

$$S_1 = \frac{3a+3b+3c}{2} = 3 \frac{(a+b+c)}{2} = 3s$$

$$A_1 = \sqrt{s_1(s_1-3a)(s_1-3b)(s_1-3c)}$$

$$= \sqrt{3s \cdot 3(s-a) \cdot 3(s-b) \cdot 3(s-c)}$$

$$= 9\sqrt{s(s-a)(s-b)(s-c)} = 9A.$$

$$\therefore \text{Increase in area} = 9A - A \\ = 8A \text{ or } 800\%.$$

10. Ans. (a)

Here, $a=60, b=40$ and $d=80$

$$\therefore s = \frac{a+b+d}{2} = \frac{60+40+80}{2} = 90.$$

\therefore Area of the parallelogram

$$= 2\sqrt{s(s-a)(s-b)(s-d)}$$

$$= 2\sqrt{90(90-60)(90-40)(90-80)}$$

$$= 2\sqrt{90 \times 30 \times 50 \times 10}$$

$$= 600\sqrt{15} \text{ sq m.}$$

11. Ans. (a)

$$\text{The area of the parallelogram} \\ = 10 \times 7 = 70 \text{ sq m}$$

12. Ans. (a)

Area of quadrilateral ABCD

$$= \text{Area of } \triangle ADC + \text{Area of } \triangle ABC,$$

Where,

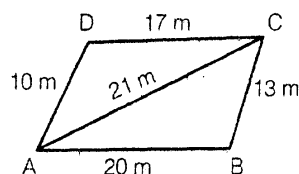

Area of ΔABC

$$= \sqrt{s(s-AB)(s-BC)(s-d)}$$

$$\left(s = \frac{AB+BC+d}{2} = \frac{20+13+21}{2} = 27 \right)$$

$$= \sqrt{27(27-20)(27-13)(27-21)}$$

$$= \sqrt{27 \times 7 \times 14 \times 6} = 126 \text{ sq m.}$$

Area of ΔACD

$$= \sqrt{s(s-AD)(s-DC)(s-d)}$$

$$\left(s = \frac{AD+DC+d}{2} = \frac{10+17+21}{2} = 24 \right)$$

$$= \sqrt{24(24-10)(24-17)(24-21)}$$

$$= \sqrt{24 \times 14 \times 7 \times 3} = 84 \text{ sq m.}$$

Here, the area of quadrilateral ABCD

$$= 126+84=210 \text{ sq m.}$$

13. Ans. (b)

We have,

$$d_1^2 + d_2^2 = 2(a^2 + b^2)$$

$$\Rightarrow (16)^2 + d_2^2 = 2(12^2 + 14^2)$$

$$\Rightarrow d_2^2 = 2(144 + 196) - 256 = 424.$$

$$\therefore d_2 = \sqrt{424} = 20.6 \text{ cm.}$$

14. Ans. (a)

If x be the side of the square and r be the radius of the circle, then

$$4x = 2\pi r$$

$$\text{or, } x = \frac{\pi r}{2}$$

$$\text{Now, } \pi r^2 : : x^2 = \pi r^2 : : \frac{\pi^2 r^2}{4} \text{ or, } 4 : \pi$$

$$= 4 : \frac{22}{7} \text{ or, } 14 : 11.$$

15. Ans. (c)

The distance covered by the wheel in one m

$$= \frac{66 \times 1000 \times 100}{60} = 110000 \text{ cm}$$

The distance covered by the wheel in one revolution

= The circumference of the wheel

$$= 2\pi r = 2 \times \frac{22}{7} \times \frac{70}{2} = 220 \text{ cm}$$

\therefore Number of the revolution of the wheel =

$$\frac{110000}{220} = 500.$$

16. Ans. (d)

$$\frac{1}{2}(75+x) \times 40 = 2500$$

$$\Rightarrow 75+x = 125$$

$$\Rightarrow x = 50$$

\therefore The other parallel side = 50 m

17. Ans. (c)

Let x, y be the sides of squares

$$\frac{x^2}{y^2} = \frac{9}{1} \Rightarrow \frac{x}{y} = \frac{3}{1}$$

\therefore The ratio of perimeters is $4x : 4y$

i.e. $x : y = 3 : 1$

18. Ans. (c)

Additional grassy ground grazed

$$= \pi(23^2 - 12^2) \text{ m}^2 = \pi \cdot 385$$

$$= \frac{22}{7} \times 35 \times 11 = 1210 \text{ m}^2$$

19. Ans. (a)

Area of the rectangular field

$$= \frac{28000}{3500} = 8 \text{ square hectare}$$

$$2x \times x = 80000$$

$$\therefore x = \sqrt{40000} = 200$$

\therefore Breadth = 200 m

$$\text{Length} = 400 \text{ m}$$

$$\text{Perimeter} = 2(400+200) = 1200 \text{ m}$$

∴ Cost of fencing

$$= 1200 \times 5 = \text{Rs. } 6000$$

20. Ans. (c)

Area of Sector

$$= \left(\frac{1}{2} \times \text{arc length} \times \text{radius} \right) \text{cm}^2$$

$$= \left(\frac{1}{2} \times 3.5 \times 5 \right) \text{cm}^2 = 8.75 \text{ cm}^2$$

21. Ans. (c)

Area of remaining portion

= Area of rectangle – Area of circle

$$= 4 \times 2 - \pi \times (1)^2 = (8 - \pi) \text{ cm}^2$$

22. Ans. (d)

Area of rectangle = $6.4 \times 2.5 = 16 \text{ m}^2$

According to question:

Area of square = Area of the rectangle

∴ Area of square = 16 m^2

∴ Side of the square = 4m

23. Ans. (c)

Let length = a m and breadth = b m

Then, $2(a + b) = 46$

or, $a + b = 23$ and $ab = 120$

$$\therefore \text{Diagonal} = \sqrt{a^2 + b^2} = \sqrt{(a+b)^2 - 2ab}$$

$$= \sqrt{(23)^2 - 2 \times 120} = \sqrt{289} = 17 \text{ m}$$

24. Ans. (c)

$$\text{Area of an equilateral } \Delta = \frac{\sqrt{3}}{4} a^2$$

$$[3a = 132 \therefore a = 44]$$

$$= \frac{\sqrt{3}}{4} \times 44 \times 44 = 838.312 \text{ sq m}$$

$$\text{Area of square} = a^2 = 33 \times 33$$

$$= 1089 \text{ sq m. } \left[a = \frac{132}{4} = 33 \right]$$

Area of regular hexagon

$$= \frac{3\sqrt{3}a^2}{2} = \frac{3\sqrt{3} \times 22 \times 22}{2}$$

$$\left[a = \frac{132}{6} = 22 \right]$$

Area of circle = πr^2

$$= \frac{22}{7} \times 21 \times 21 \left[r = \frac{132}{2\pi} = 21 \right]$$

∴ Circle has largest surface area.

25. Ans. (b)

Circumference

$$= \left(2 \times \frac{22}{7} \times 70 \right) \text{cm} = 440 \text{ cm}$$

Distance travelled in 10 revolutions

$$= 4400 \text{ cm} = 44 \text{ m}$$

$$\therefore \text{Speed} = \frac{\text{Distance}}{\text{Time}} = \left(\frac{44}{5} \right) \text{m/sec}$$

$$= \left(\frac{44}{2} \times \frac{18}{5} \right) \text{km/hr} = 31.68 \text{ km/hr}$$

26. Ans. (a)

Let the length of the big rectangle be x m

∴ Area of the big rectangle

$$= x \times 2 = 2x \text{ m}^2$$

∴ Area of the small rectangle

$$= \frac{1}{6} \times 2x = \frac{x}{3} \text{ m}^2$$

∴ Breadth of the small rectangle

$$= \frac{x}{3} + x = \frac{4x}{3} \text{ m}$$

27. Ans. (b)

Length of each side of hexagon = r

∴ Its perimeter = 6r.

28. Ans (b)

$$2\pi R - 2\pi r = 44\text{m}$$

$$\therefore 2\pi(R-r) = 44\text{m}$$

$$\text{or, } R-r = 44 \div 2\pi$$

$$= 44 \div \left(2 \times \frac{22}{7}\right) = 7\text{m}$$

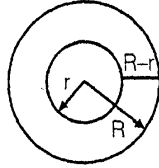

29. Ans. (c)

$$\text{Area of garden} = 24 \times 14 = 336\text{m}^2$$

$$\text{Area of the (garden+path)} = 26 \times 16 = 416\text{m}^2$$

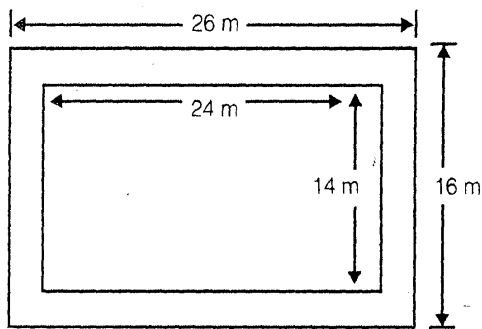

$$\therefore \text{Area of the path} = 416 - 336 = 80\text{m}^2$$

$$\begin{aligned} \text{Area of 1 tile} &= 20 \times 20 = 400\text{ cm}^2 \\ &= 0.04\text{ m}^2 \end{aligned}$$

\therefore Number of tiles required

$$= \frac{80}{0.04} = 2000$$

30. Ans. (c)

$$\frac{1}{2} \times 24 \times h = \frac{\sqrt{3}}{4} \times 24 \times 24$$

$$\text{or, } h = 12\sqrt{3}$$

$$\therefore 3r = 12\sqrt{3} \Rightarrow r = 4\sqrt{3}\text{ cm}$$

Area of the circle

$$= \pi \times (4\sqrt{3})^2\text{ cm}^2 = 48\pi\text{ cm}^2$$



Triangles & Quadrilaterals



Practice Exercise: II

- The perimeter of a rectangular field is 480 meters and the ratio between the length and breadth is 5 : 3. The area of the field is :
 (a) 7200 m² (b) 15000 m²
 (c) 13500 m² (d) 54000 m²
- If each side of a square is increased by 50%, the ratio of the area of the resulting square to the area of the given square is :
 (a) 5 : 4 (b) 9 : 4
 (c) 4 : 5 (d) 4 : 9
- If the diagonal of a square is doubled to make the diagonal of another square, the area of the new square will:
 (a) becomes two folds
 (b) becomes three folds
 (c) becomes four folds
 (d) remains the same
- A hall 20 m long and 15 m broad is surrounded by a verandah of uniform width of 2.5m. The cost of flooring the verandah at Rs. 3.50 per square meters, is
 (a) Rs. 500 (b) Rs. 600
 (c) Rs. 700 (d) Rs. 800
- A man walking at the speed of 4 kmph crosses a square field diagonally in 3 minutes. The area of the field is:
 (a) 18000 m² (b) 20000 m²
 (c) 19000 m² (d) 25000 m²
- If the perimeters of a square and a rectangle are the same, then the areas A and B enclosed by them would satisfy the condition:
 (a) A < B (b) A ≤ B
 (c) A > B (d) A ≥ B

7. If the perimeter of a rectangle and a square, each is equal to 80 cm and the difference of their areas is 100 Sq. cm, the sides of the rectangle are:
 (a) 35 cm, 15 cm (b) 30 cm, 10 cm
 (c) 28 cm, 12 cm (d) 25 cm, 15 cm
8. The length of a rectangle is twice its breadth. If its length is decreased by 5 cm and breadth is increased by 5 cm, the area of the rectangle is increased by 75 sq. cm. The length of the rectangle is:
 (a) 20 cm (b) 30 cm
 (c) 40 cm (d) 50 cm
9. Within a rectangular garden 10 m wide and 20 m long, we wish to pave a walk around the borders of uniform width so as to leave an area of 96 m^2 for flowers. How wide should the walk be?
 (a) 1 m (b) 2 m
 (c) 2.1 m (d) 2.5 m
10. A rectangular field has dimensions 25 m by 15 m. Two mutually perpendicular passages, 2m wide have been left in the central part. In rest of the field, grass has been grown. The area under the grass is :
 (a) 295 m^2 (b) 299 m^2
 (c) 300 m^2 (d) 375 m^2
11. The length of rectangle is twice its breadth and one of its diagonals measures $10\sqrt{5}\text{ cm}$. The perimeter of the rectangle is:
 (a) 60 cm (b) 50 cm
 (c) 250 m (d) None
12. A hall 36 m long and 15 m broad is to be paved with stones, each measuring 6 dm by 5 dm. The number of stones required is:
 (a) 180 (b) 1800
 (c) 18 (d) 18000
13. A rectangle has 15 cm as its length and 150 sq. cm as its area. If the area is increased to $1\frac{1}{3}$ times the original area by increasing its length only, then the new perimeter is:
 (a) 50 cm (b) 60 cm
 (c) 70 cm (d) 80 cm
14. A room 5.44 m long and 3.74 m broad is to be paved with square tiles. The least number of square tiles required to cover the floor is:
 (a) 176 (b) 192
 (c) 184 (d) 162
15. A man cycles round the boundary of a rectangular park at the rate of 12 kmph and completes one full round in 8 minutes. If the ratio between the length and breadth of the park be 3:2, then its area is :
 (a) 1536 m^2 (b) 15360 m^2
 (c) 153600 m^2 (d) None
16. The area of a square is 0.5 hectare. Its diagonal is:
 (a) 50 m (b) 100 m
 (c) 250 m (d) $50\sqrt{2}\text{ m}$
17. If the base of a rectangle is increased by 10% and the area is unchanged, then the corresponding altitude must be decreased by:
 (a) 10% (b) $9\frac{1}{11}\%$
 (c) 11% (d) $11\frac{1}{9}\%$
18. The length and breadth of a square are increased by 40% and 30% respectively. The area of the resulting rectangle exceeds the area of the square by:
 (a) 35% (b) 42%
 (c) 62% (d) 82%
19. The height of a room to its semi-perimeter is 2:5. It costs Rs. 260 to paper the walls of the room with paper 50 cm wide at Rs. 2 per metre allowing an area of 15 sq. m. for doors

and windows. The height of the room is:

- (a) 2.6 m (b) 3.9 m
(c) 4 m (d) 4.2 m

20. If the area of a rhombus is 15 sq. cm and the length of one of its diagonals is 5 cm, then the length of the other diagonal is:

- (a) 3 cm (b) 5 cm
(c) 6 cm (d) 7 cm

21. The length of one diagonal of a rhombus is 80% of the other diagonal. The area of the rhombus is how many times the square of the length of the longer diagonal?

- (a) $\frac{4}{5}$ (b) $\frac{2}{5}$
(c) $\frac{3}{4}$ (d) $\frac{1}{4}$

22. If a square and a rhombus stand on the same base, then the ratio of the areas of the square and the rhombus is :

- (a) greater /than 1 (b) equal to 1
(c) equal to $\frac{1}{2}$ (d) equal to $\frac{1}{4}$

23. A parallelogram has sides 30m and 14m and one of its diagonals is 40m long. Then, its area is:

- (a) 336 m² (b) 168 m²
(c) 480 m² (d) 372 m²

24. The two parallel sides of a trapezium are 1.5 and 2.5 m respectively. If the perpendicular distance between them is 6.5 meters, the area of the trapezium is:

- (a) 26 m² (b) 13 m²
(c) 20 m² (d) 10 m²

25. The three sides of a triangle are 3 cm, 4 cm and 5 cm respectively. Then its area (in sq. cm) is:

- (a) $4\sqrt{2}$ (b) $2\sqrt{3}$
(c) $\sqrt{23}$ (d) 6

26. If the area of an equilateral triangle is $24\sqrt{3}$ sq. cm, then its perimeter is:

- (a) 96 cm (b) $12\sqrt{6}$ cm
(c) $4\sqrt{6}$ cm (d) $2\sqrt{6}$ cm

27. If x is the length of a median of an equilateral triangle, then its area is:

- (a) x^2 (b) $\frac{1}{2}x^2$
(c) $\frac{x^2\sqrt{3}}{2}$ (d) $\frac{x^2\sqrt{3}}{3}$

28. If the area of a square with side a is equal to the area of a triangle with base a , then the altitude of the triangle is :

- (a) $\frac{a}{2}$ (b) a
(c) $2a$ (d) $4a$

29. If the altitude of an equilateral triangle is $\sqrt{6}$, then its area is :

- (a) $3\sqrt{3}$ (b) $2\sqrt{3}$
(c) $2\sqrt{2}$ (d) $6\sqrt{2}$

30. If the circumference of a circle is 352 metres, then its area (in sq. m) is:

- (a) 5986 (b) 6589
(c) 8956 (d) 9856

31. The circumferences of two concentric circle forming a ring are 88 cm and 66 cm respectively. The width of the ring is :

- (a) 3.5 cm (b) 10.5 cm
(c) 7 cm (d) 14 cm

32. The diameter of a wheel is 1.26 m. How far will it travel in 500 revolutions?

- (a) 2530 m (b) 1980 m
(c) 1492 m (d) 2880 m

33. If the wheel of an engine of train $4\frac{2}{7}$ m in circumference makes seven revolutions in 4 seconds, then the speed of the train is :
- (a) 25 km/hr (b) 27 km/hr
(c) 30 km/hr (d) 35 km/hr

34. A toothed wheel of diameter 50 cm is attached to a smaller wheel of diameter 30 cm. How many revolutions will the smaller wheel make when the larger one makes 15 revolutions?

- (a) 18 (b) 20
(c) 25 (d) 30

35. If the diameter of a circle is increased by 100%, its area is increased by :

- (a) 100% (b) 200%
(c) 300% (d) 400%

36. The area of the largest circle that can be drawn inside a square of side 14cm in length, is:

- (a) 154 cm^2 (b) 84 cm^2
(c) 204 cm^2 (d) None of these

37. The area of largest possible square inscribed in a circle of unit radius (in sq. units) is :

- (a) 2 (b) π
(c) $2\sqrt{2}\pi$ (d) $4\sqrt{2}\pi$

38. The ratio of the areas of the incircle and circumcircle of an equilateral triangle is :

- (a) 1 : 2 (b) 1 : 3
(c) 1 : 4 (d) 1 : 9

39. A circular wire ring of radius 42 cm is cut and bent into the form of a rectangle whose sides are in the ratio of 6 : 5. The smaller side of the rectangle is :

- (a) 30 cm (b) 60 cm
(c) 72 cm (d) 132 cm

40. Four horses are tethered at four corners of a square plot of side 63 metres so that they just can not reach one another. The area left ungrazed is :

- (a) 675.5 m^2 (b) 780.6 m^2
(c) 785.8 m^2 (d) 850.5 m^2

Solutions

1. Ans. (c)

Let length = $5x$ and breadth = $3x$. Then,
 $2(5x + 3x) = 480$ or $x = 30$.

\therefore Length = 150m & breadth = 90m.

$$\text{Area} = (150 \times 90) \text{m}^2 = 13500 \text{m}^2.$$

2. Ans. (b)

Let, each side = a . Then, original area = a^2 .

$$\text{New side} = \frac{150a}{100} = \frac{3a}{2}$$

$$\text{New area} = \frac{9a^2}{4}$$

$$\text{Required ratio} = \frac{9a^2}{4} : a^2 = 9 : 4.$$

3. Ans. (c)

Let the diagonal be a . Then, area = $\frac{1}{2}a^2$

New diagonal = $2a$.

$$\therefore \text{New Area} = \frac{1}{2}(2a)^2 = 2a^2 = 4 \left(\frac{1}{2}a^2 \right) = 4$$

(Original area).

4. Ans. (c)

Area of the verandah

$$= (25 \times 20 - 20 \times 15) \text{m}^2 = 200 \text{m}^2$$

\therefore Cost of flooring

$$= \text{Rs.} \left(200 \times \frac{7}{2} \right) = \text{Rs.} 700.$$

5. Ans. (b)

Length of diagonal = Distance covered in 3 min. at 4 km/hr.

$$= \left(\frac{4000}{60} \times 3 \right) \text{m} = 200 \text{m}.$$

$$\therefore \text{Area of the field} = \frac{1}{2}(\text{diagonal})^2$$

$$= \left(\frac{1}{2} \times 200 \times 200 \right) \text{m}^2 = 20000 \text{m}^2.$$

6. Ans. (c)

Let, side of square = a, length of rect. = x & breadth of rect. = y.

$$4a = 2(x+y) \Rightarrow \frac{x+y}{2} = a.$$

$$\text{Area of square} = a^2 = \left(\frac{x+y}{2} \right)^2$$

$$\text{So, } A = \left(\frac{x+y}{2} \right)^2$$

Area of rect. = xy. So, B = xy.

$$\frac{x+y}{2} > x^{1/2}y^{1/2} \quad [\because \text{A. M.} > \text{G. M.}]$$

$$\Rightarrow \left(\frac{x+y}{2} \right)^2 > xy \text{ i.e. } A > B.$$

Remember: If a square & a rectangle have same perimeter, then :

(Area of square) > (Area of rectangle).

7. Ans. (b)

Perimeter of square = 80cm. So, side of square = 20 cm.

Area of the square

$$= (20 \times 20) \text{cm}^2 = 400 \text{cm}^2.$$

With same perimeter, area of the square is larger.

$$\therefore \text{Area of rectangle} = (400 - 100) \text{cm}^2$$

$$= 300 \text{cm}^2.$$

Let, length of rect. = x & its breadth = y. then, xy = 300 and x + y = 40

$$\therefore (x-y) = \sqrt{(x+y)^2 - 4xy}$$

$$= \sqrt{1600 - 1200} = 20.$$

Solving $x+y=40$ & $x-y=20$, we get $x=30$, $y=10$.

\therefore Sides are 30 cm, 10 cm.

8. Ans.(c)

Let, breadth = x, Then, length = 2x.

$$(2x-5)(x+5) - 2x \times x = 75 \text{ or } x = 20.$$

\therefore Length = 40 cm.

9. Ans. (b)

Let the width of walk be x metres. Then,

$$(20 - 2x)(10 - 2x) = 96$$

$$\text{or } 4x^2 + 60x - 104 = 0$$

$$\text{or } x^2 + 15x - 26 = 0$$

$$\text{or } (x-13)(x-2) = 0$$

$$\text{So, } x = 2 \quad [\because x \neq 13]$$

$$\text{So, } x = 2 \quad [\because x \neq 13]$$

10. Ans. (b)

Area of cross roads

$$= (25 \times 2 + 15 \times 2 - 2 \times 2) \text{m}^2 = 76 \text{m}^2.$$

$$\text{Area of the field} = (25 \times 15) \text{m}^2 = 375 \text{m}^2$$

Area under grass

$$= (375 - 76) \text{m}^2 = 299 \text{m}^2$$

11. Ans. (a)

Let breadth = x cm and length = 2x cm.

$$\text{Then, } x^2 + (2x)^2 = (10\sqrt{5})^2$$

$$\text{or } 5x^2 = 500 \quad \text{or } x^2 = 100 \quad \text{or } x = 10.$$

\therefore Perimeter

$$= 2(2x+x) \text{cm} = 6x \text{cm} = 60 \text{cm}.$$

12. Ans. (b)

$$\text{Area of the hall} = (3600 \times 1500) \text{sq. cm.}$$

$$\text{Area of each stone} = (60 \times 50) \text{sq. cm.}$$

\therefore Number of stones

$$= \left(\frac{3600 \times 1500}{60 \times 50} \right) = 1800.$$

13. Ans. (b)

$$\text{Breadth} = \left(\frac{150}{15} \right) \text{cm} = 10 \text{ cm.}$$

$$\text{New area} = \left(\frac{4}{3} \times 150 \right) \text{sq. cm} = 200 \text{ sq. cm}$$

$$\therefore \text{New length} = \left(\frac{200}{10} \right) \text{cm} = 20 \text{ cm.}$$

$$\text{New Perimeter} = 2(20+10) \text{cm} = 60 \text{ cm.}$$

14. Ans. (a)

Area of the room = (544×374) sq. cm
Size of largest square tile = H. C. F. of 544 cm & 374 cm = 34 cm.

Area of 1 tile = (34×34) sq. cm

$$\therefore \text{Number of tiles} = \left(\frac{544 \times 374}{34 \times 34} \right) = 176.$$

15. Ans. (b)

Perimeter = Distance covered in 8 min.

$$= \left(\frac{12000}{60} \times 8 \right) \text{m} = 1600 \text{ m.}$$

Let, length = $3x$ metres and breadth = $2x$ metres.

Then, $2(3x+2x) = 1600$ or $x = 160$.

\therefore Length = 480 m and breadth = 320 m

$$\therefore \text{Area} = (480 \times 320) \text{m}^2 = 153600 \text{m}^2$$

16. Ans.(b)

$$\text{Area} = \left(\frac{1}{2} \times 10000 \right) \text{m}^2 = 5000 \text{m}^2.$$

$$\therefore \frac{1}{2}(\text{diagonal})^2 = 5000$$

$$\text{or } (\text{diagonal})^2 = 10000$$

$$\therefore \text{Diagonal} = \sqrt{10000} = 100 \text{m}$$

17. Ans. (b)

Let, length = a & breadth = b .

Then, area = ab .

$$\text{New length} = \frac{110}{100}a = \frac{11a}{10}.$$

Let new breadth = c .

$$\text{Then, } \frac{11a}{10} \times c = ab \text{ or } c = \frac{10b}{11}.$$

18. Ans. (d)

Percentage increase in the area of rectangle

$$= \left(x + y + \frac{xy}{100} \right) \%$$

$$= \left(40 + 30 + \frac{40 \times 30}{100} \right) \% = 82\%$$

19. Ans. (c)

Let, height = $2x$ metres &

(length + breadth) = $5x$ metres.

$$\text{Length of paper} = \left(\frac{260}{2} \right) \text{m} = 130 \text{m.}$$

$$\therefore \text{Area of paper} = \left(130 \times \frac{50}{100} \right) \text{m}^2 = 65 \text{m}^2$$

$$\text{Area of 4 walls} = (65+15) \text{m}^2 = 80 \text{m}^2.$$

$$2(\text{length} + \text{breadth}) \times \text{height} = 80$$

$$\therefore 2 \times 5x \times 2x = 80 \text{ or } x^2 = 4 \text{ or } x=2.$$

\therefore Height of the room = 4m.

20. Ans. (c)

$$\text{Area} = \frac{1}{2} \times (\text{Product of diagonals})$$

$$\therefore \frac{1}{2} \times 5 \times x = 15 \Rightarrow x = \left(15 \times \frac{2}{5} \right) = 6 \text{ cm.}$$

21. Ans. (b)

Let one diagonal = x cm.

$$\text{Another diagonal} = \frac{80}{100}x = \frac{4x}{5} \text{ cm.}$$

$$\text{Area of rhombus} = \frac{1}{2} \left(x \times \frac{4x}{5} \right) = \frac{2}{5}x^2$$

$$= \frac{2}{5} \text{ (square of longer diagonal).}$$

22. Ans. (b)

A square and a rhombus on the same base are equal in area.

23. Ans. (a)

Let $ABCD$ be a parallelogram in which $AB = 30\text{m}$, $BC = 14\text{m}$ & $AC = 40\text{m}$.

Clearly, area of parallelogram $ABCD = 2$ (area of ΔABC).

Let $a = 30$, $b = 14$ & $c = 40$.

$$\text{Then, } s = \frac{1}{2}(a + b + c) = 42$$

$$\therefore \text{Area of } \Delta ABC = \sqrt{s(s-a)(s-b)(s-c)}$$

$$= \sqrt{42 \times 12 \times 28 \times 2} = 168 \text{ m}^2.$$

\therefore Area of parallelogram

$$= (2 \times 168) \text{m}^2 = 336 \text{ m}^2.$$

24. Ans. (b)

$$\text{Area of trap.} = \frac{1}{2} (\text{Sum of parallel sides} \times$$

distance between them)

$$= \left[\frac{1}{2} (1.5 + 2.5) \times 6.5 \right] \text{m}^2 = 13 \text{m}^2.$$

25. Ans. (d)

$a = 3$, $b = 4$ and $c = 5$.

$$\therefore s = \frac{1}{2}(3 + 4 + 5) = 6$$

$$\therefore \text{Area} = \sqrt{6 \times 3 \times 2 \times 1} = \sqrt{36} = 6 \text{ sq. cm.}$$

26. Ans. (a)

$$\frac{\sqrt{3}a^2}{4} = 24\sqrt{3} \Rightarrow a^2 = 96 \text{ or } a = 4\sqrt{6}.$$

$$\therefore \text{Perimeter} = (3 \times 4\sqrt{6}) \text{ cm} = 12\sqrt{6} \text{ cm.}$$

27. Ans. (d)

Let the side of the triangle be a .

$$a^2 = \left(\frac{a}{2}\right)^2 + x^2 \text{ or } \frac{3a^2}{4} = x^2$$

$$\text{or } a^2 = \frac{4x^2}{3}.$$

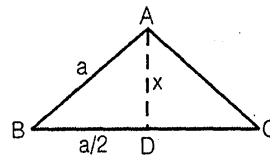

$$\therefore \text{Area} = \frac{\sqrt{3}}{4}a^2 = \frac{\sqrt{3}}{4} \times \frac{4}{3}x^2$$

$$= \frac{x^2}{\sqrt{3}} = \frac{x^2\sqrt{3}}{3}.$$

28. Ans. (c)

$$\frac{1}{2} \times a \times \text{altitude} = a^2 \Rightarrow \text{altitude} = 2a.$$

29. Ans. (b)

$$\text{Area} = \frac{1}{2} \times \text{base} \times \text{height}$$

$$\therefore \frac{1}{2} \times \frac{\sqrt{3}}{4} a^2$$

$$\text{or } a = \frac{2\sqrt{6}}{\sqrt{3}} = 2\sqrt{2}.$$

$$\therefore \text{Area} = \frac{\sqrt{3}}{4} \times (2\sqrt{2})^2 = 2\sqrt{3}$$

30. Ans. (d)

$$2\pi r = 352 \Rightarrow 2 \times \frac{22}{7} \times r = 352.$$

$$\therefore r = \left(352 \times \frac{7}{44} \right) = 56 \text{ m.}$$

$$\therefore \text{Area} = \left(\frac{22}{7} \times 56 \times 56 \right) \text{m}^2 = 9856 \text{ m}^2.$$

31. Ans. (a)

Let, inner radius = r & outer radius = R cm.

$$\text{Then, } 2 \times \frac{22}{7} \times R = 88$$

$$\Rightarrow R = \left(88 \times \frac{7}{44} \right) = 14 \text{ cm.}$$

$$2 \times \frac{22}{7} \times r = 66$$

$$\Rightarrow r = \left(66 \times \frac{7}{44} \right) = \frac{21}{2} \text{ cm} = 10.5 \text{ cm.}$$

$$\therefore \text{width of the ring} = (14 - 10.5) \text{ cm} \\ = 3.5 \text{ cm.}$$

32. Ans. (b)

Radius of the wheel = 0.63 m.

Distance moved in 1 revolution = circumference

$$= \left(2 \times \frac{22}{7} \times 0.63 \right) \text{m} = 3.96 \text{ m.}$$

$$\text{Distance moved in 500 revolutions} \\ = (500 \times 3.96) \text{m} = 1980 \text{ m.}$$

33. Ans. (b)

Distance moved in 4 sec.

$$= \left(\frac{30}{7} \times 7 \right) \text{m} = 30 \text{ m.}$$

$$\therefore \text{Speed} = \left(\frac{30}{4} \times 60 \times 60 \times \frac{1}{1000} \right) \text{km/hr}$$

$$= 27 \text{ km/hr}$$

34. Ans. (c)

Distance moved by toothed wheel in

$$15 \text{ revolution} = \left(15 \times 2 \times \frac{22}{7} \times 25 \right) \text{cm.}$$

Distance moved by smaller wheel in 1 revolution

$$= \left(2 \times \frac{22}{7} \times 15 \right) \text{cm.}$$

\therefore Required number of revolutions

$$= \left(15 \times \frac{44}{7} \times 25 \times \frac{7}{44 \times 15} \right) = 25.$$

35. Ans. (c)

Let original radius = R ,

$$\text{New Radius} = \frac{200}{100} R = 2R.$$

\therefore Original area = πR^2 ,

$$\text{New area} = \pi (2R)^2 = 4\pi R^2$$

$$\therefore \text{Increase\%} = \left(\frac{3\pi R^2}{\pi R^2} \times 100 \right) \% = 300\%$$

36. Ans. (a)

Radius of the required circle = 7cm.

$$\therefore \text{Its area} = \left(\frac{22}{7} \times 7 \times 7 \right) \text{cm}^2 = 154 \text{ cm}^2.$$

37. Ans. (a)

Diagonal of square = Diameter of circle = 2 units.

$$\therefore \text{Area of the square} = \frac{1}{2} \times (\text{diagonal})^2$$

$$= \left(\frac{1}{2} \times 2 \times 2 \right) = 2 \text{ sq. units.}$$

38. Ans. (c)

Let radius of incircle be r . Then, radius of circumcircle = $2r$.

$$\therefore \text{Required ratio} = \frac{\pi r^2}{\pi (2r)^2} = \frac{1}{4}.$$

39. Ans. (b)

Length of a wire ring = circumference of circle of radius 42 cm

$$= \left(2 \times \frac{22}{7} \times 42 \right) \text{cm} = 264 \text{ cm.}$$

∴ Perimeter of rectangle = 264 cm

Let, length = 6x cm & breadth = 5x cm.

$$\therefore 2(6x + 5x) = 264 \text{ or } x = 12,$$

∴ Smaller side = 60 cm.

40. Ans. (d)

Required area

$$= \left(63 \times 63 - 4 \times \frac{1}{4} \times \frac{22}{7} \times \frac{63}{2} \times \frac{63}{2} \right) \text{m}^2$$

$$= 850.5 \text{ m}^2$$



Mensuration & Solid Geometry



Practice Exercise: I

- The perimeter of an equilateral triangle is $72\sqrt{3}$ cm. Find its height.
 - 63 cm
 - 24 cm
 - 18 cm
 - 36 cm
- The inner circumference of a circular track is 440 cm. The track is 14 cm wide. Find the diameter of the outer circle of the track.
 - 84 cm
 - 168 cm
 - 336 cm
 - 77 cm
- Find the area of a quadrant of a circle whose circumference is 44 cm.
 - 77 cm^2
 - 38.5 cm^2
 - 19.25 cm^2
 - $19.25\pi \text{ cm}^2$
- Find the length of the longest pole that can be placed in an indoor stadium 24 metre long, 18 metre wide and 16 metre high.
 - 30 metres
 - 25 metres
 - 34 metres
 - $\sqrt{580}$ metres
- The length, breadth and height of a room are in the ratio of 3 : 2 : 1. If its volume be 1296 m^3 , find its breadth.
 - 12 metres
 - 18 metres
 - 16 metres
 - 24 metres
- The volume of a cube is 216 cm^3 . Part of this cube is melted to form a cylinder of area 8788 square cm. If length, breadth and height are in the ratio of 4 : 3 : 2, find length.
 - 342 cm^3
 - 216 cm^3
 - 36 cm^3
 - Data inadequate
- Three metal cubes with edges 6 cm, 8cm and 10 cm respectively are melted together and formed into a single cube. Find the side of the resulting cube.
 - 11 cm
 - 12 cm
 - 13 cm
 - 24 cm
- The diameters of two cones are equal. If their slant height be in the ratio 5 : 7, find the ratio of their curved surface areas.
 - 25 : 7
 - 25 : 49
 - 5 : 49
 - 5 : 7
- The ratio of radii of a cylinder to a that of a cone is 1 : 2. If their heights are equal, find the ratio of their volumes?
 - 1 : 3
 - 2 : 3
 - 3 : 4
 - 3 : 2
- A bicycle wheel makes 5000 revolutions in moving 11 km. What is the radius of the wheel?
 - 70 cm
 - 135 cm
 - 17.5 cm
 - 35 cm
- The surface areas of two spheres are in the ratio of 1 : 4. Find the ratio of their volumes.
 - 1 : 3
 - 1 : 8
 - 1 : 4
 - 1 : 2

12. The radii of two spheres are in the ratio of 1 : 2. Find the ratio of their surface areas.

- (a) 1 : 3 (b) 2 : 3
(c) 1 : 4 (d) 3 : 4

13. A sphere of radius r has the same volume as that of a cone with a circular base of radius r . Find the height of cone.

- (a) $2r$ (b) $r/3$
(c) $4r$ (d) $(2/3)r$

14. A road that is 7m wide surrounds a circular path whose circumference is 352m. What will be the area of the road?

- (a) 2618 m^2 (b) 654.5 m^2
(c) 1309 m^2 (d) 5236 m^2

15. How many metres of cloth 5 m wide will be required to make a conical tent, the radius of whose base is 7 m and height is 24 m?

- (a) 55 m (b) 330 m
(c) 220 cm (d) 110 m

16. A cuboid of dimension $24\text{cm} \times 9\text{cm} \times 8\text{cm}$ is melted and smaller cubes are of side 3 cm is formed. Find how many such cubes can be formed?

- (a) 27 (b) 64
(c) 54 (d) 32

17. Three cubes each of volume of 216 m^3 are joined end to end. Find the surface area of the resulting figure.

- (a) 504 m^2 (b) 216 m^2
(c) 432 m^2 (d) None of these

18. In the adjacent figure, find the area of the shaded region. (Use $\pi = 22/7$)

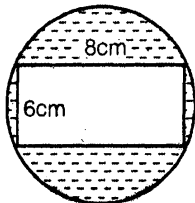

- (a) 15.28 cm^2 (b) 61.14 cm^2
(c) 30.57 cm^2 (d) 40.76 cm^2

19. The diagram represents the area swept by the wiper of a car. With the dimensions given in the figure, calculate the shaded area swept by the wiper.

- (a) 102.67 cm^2
(b) 205.34 cm^2
(c) 51.33 cm^2
(d) Cannot be determined

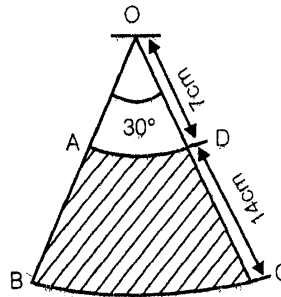

20. Find the area of quadrilateral ABCD. (Given,

$$(\sqrt{3} = 1.73)$$

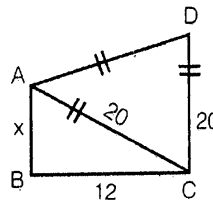

- (a) 452 sq units
(b) 269 sq units
(c) 134.5 sq units
(d) Cannot be determined

Solutions

1. Ans. (d)

Given, Perimeter of equilateral triangle =

$$72\sqrt{3} \text{ cm}$$

\therefore Side of equilateral triangle

$$= \frac{72\sqrt{3}}{3} \text{ cm} = 24\sqrt{3} \text{ cm}$$

Let the height of the given triangle be h .

Then, Area of the triangle

$$= \frac{\sqrt{3}}{4}(\text{side})^2 = \frac{1}{2} \times \text{Base} \times \text{Height}$$

$$\Rightarrow \frac{\sqrt{3}}{4}(24\sqrt{3})^2 = \frac{1}{2} \times 24\sqrt{3} \times h$$

$$\text{Hence, } h = \frac{\sqrt{3} \times 24\sqrt{3}}{2} = 36 \text{ cm}$$

2. Ans. (b)

Inner circumference of the circular track

$$= 2\pi r = 440 \text{ cm}$$

$$\therefore r = \frac{440}{2\pi} = 70 \text{ cm}$$

\therefore Radius of outer circle of track

$$= (70 + 14) \text{ cm} = 84 \text{ cm}$$

\therefore Diameter of outer circle of track

$$= 2 \times 84 = 168 \text{ cm}$$

3. Ans. (b)

Circumference of the circle

$$= 2\pi r = 44 \text{ cm}$$

$$\therefore \text{Radius of the circle} = \frac{44}{2\pi}$$

$$= \frac{44}{2 \times \frac{22}{7}} = 7 \text{ cm}$$

$$\therefore \text{Area of the circle} = \pi(7)^2 = 154 \text{ cm}^2$$

\therefore Area of a quadrant of circle

$$= \frac{154}{4} \text{ cm}^2 = 38.5 \text{ cm}^2$$

4. Ans. (c)

The length of the longest pole

= Diagonal of the indoor stadium

$$= \sqrt{(24)^2 + (18)^2 + (16)^2} \text{ metre}$$

$$= \sqrt{1156} \text{ metre} = 34 \text{ metre}$$

5. Ans. (a)

Let the length, breadth and height of the room be $3x$, $2x$ & x metre.

Then, Volume of the room

$$= (3x)(2x)(x) = 6x^3$$

$$\therefore 6x^3 = 1296$$

$$\therefore x = \sqrt[3]{\frac{1296}{6}} = \sqrt[3]{216} = 6 \text{ metre}$$

$$\therefore \text{Breadth of room} = 2x = 12 \text{ metre}$$

6. Ans. (d)

Volume of the cylinder

= Volume of the part of the cube melted

But what part of cube is melted is not given.

Hence, volume of the cylinder can not be determined.

Hence data is inadequate.

7. Ans. (b)

Volume of the resulting cube

= Sum of the volume of the three cubes

$$= (6)^3 + (8)^3 + (10)^3$$

$$= 1728 \text{ cm}^3$$

\therefore Side of the resulting cube

$$= \sqrt[3]{1728} \text{ cm} = 12 \text{ cm}$$

8. Ans. (d)

Let the radii and slant heights of the two cones be r_1 , l_1 & r_2 , l_2 respectively.

Given, $r_1 = r_2$

Ratio of the curved surface areas

$$= \frac{\pi r_1 l_1}{\pi r_2 l_2} = \frac{l_1}{l_2} = \frac{5}{7}$$

9. Ans. (c)

Let the radius of cylinder = r

Then, radius of cone = $2r$

Heights of cylinder = Height of cone = h

$$\text{Hence, } \frac{\text{Volume of cylinder}}{\text{Volume of cone}}$$

$$= \frac{\pi r^2 h}{\frac{1}{3}\pi(2r)^2 h} = \frac{3}{4}$$

10. Ans. (d)

Distance covered in one revolution

$$= \frac{11000}{5000} = 2.2 \text{ m} = 220 \text{ cm}$$

$$2\pi r = 220 \text{ cm (given)}$$

$$\text{So, } r = \frac{220 \times 7}{2 \times 22} = 35 \text{ cm}$$

11. Ans. (b)

Let the radii of the two spheres be r_1 & r_2 .

Ratio of surface areas of the spheres

$$= \frac{4\pi r_1^2}{4\pi r_2^2} = \frac{1}{4}$$

$$\Rightarrow \left(\frac{r_1}{r_2}\right)^2 = \frac{1}{4} \Rightarrow \frac{r_1}{r_2} = \frac{1}{2}$$

$$= \frac{\frac{4}{3}\pi r_1^3}{\frac{4}{3}\pi r_2^3} = \left(\frac{r_1}{r_2}\right)^3 = \left(\frac{1}{2}\right)^3 = \frac{1}{8}$$

12. Ans. (c)

Let the radii of the two spheres be r_1 & r_2 .

Then, ratio of the surface areas of the spheres

$$= \frac{4\pi r_1^2}{4\pi r_2^2} = \left(\frac{r_1}{r_2}\right)^2 = \left(\frac{1}{2}\right)^2 = \frac{1}{4}$$

13. Ans. (c)

Let the height of the cone be h .

Volume of the sphere = volume of the cone

$$\Rightarrow \frac{4}{3}\pi r^3 = \frac{1}{3}\pi r^2 h$$

$$\therefore h = 4r$$

14. Ans. (a)

Radius of the circular path

$$= \frac{352}{2\pi} = \frac{352}{2 \times \frac{22}{7}} = 56 \text{ metre}$$

\therefore outer radius of the Road

$$= (56 + 7)\text{m} = 63\text{m}$$

Area of the Road

$$= \pi(63)^2 - \pi(56)^2 = \pi[(63)^2 - (56)^2]$$

$$= 2618 \text{ m}^2$$

15. Ans. (d)

Slant Height of the cone l

$$= \sqrt{(7)^2 + (24)^2} \text{ m} = 25 \text{ m}$$

Hence, Surface area of the tent

$$= \pi l = \pi(7)(25) = 550\text{m}^2$$

Let the length of cloth required be x m.

$$\text{Then, } x \times 5 = 550 \Rightarrow x = 110\text{m}$$

16. Ans. (b)

$$\text{Volume of cuboid} = 24 \times 9 \times 8 \text{ cm}^3$$

$$= 24 \times 9 \times 8 \text{ cm}^3 = 1728 \text{ cm}^3$$

$$\text{Volume of cubes} = (3)^3 \text{ cm}^3 = 27 \text{ cm}^3$$

$$\therefore \text{No. of cubes formed} = \frac{1728}{27} = 64$$

17. Ans. (a)

$$\text{Side of each cube} = \sqrt[3]{216}\text{m} = 6\text{m}$$

Length of the resulting figure after joining

$$= 6 + 6 + 6 = 18\text{m}$$

The width & height of the resulting figure will be 6m each.

\therefore Surface area of the resulting figure

$$= 2(18 \times 6 + 6 \times 6 + 18 \times 6) = 504\text{m}^2$$

18. Ans. (c)

Diameter of the circle

$$= \sqrt{(8)^2 + (6)^2} = 10 \text{ cm}$$

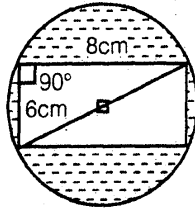

Radius of the circle = 5 cm.

$$\text{Area of circle} = \pi(5)^2 \text{ cm}^2 = 25\pi \text{ cm}^2$$

$$= 25 \times \frac{22}{7} \text{ cm}^2 = 78.57 \text{ cm}^2$$

$$\text{Area of the Rectangle} = 8 \times 6 \text{ cm}^2 = 48 \text{ cm}^2$$

∴ Area of the shaded region

$$= (78.57 - 48) \text{ cm}^2 = 30.57 \text{ cm}^2$$

19. Ans. (a)

Area of the section OBCO

$$= \pi(21)^2 \times \left(\frac{30}{360}\right) = 115.5 \text{ cm}^2$$

Area of section OADO

$$= \pi(7)^2 \left(\frac{30}{360}\right) = 12.83 \text{ cm}^2$$

∴ Area swept by the wiper

$$= \text{Area of the section OBCO}$$

$$- \text{Area of the section OADO}$$

$$= (115.5 - 12.83) \text{ cm}^2$$

$$= 102.67 \text{ cm}^2$$

20. Ans. (b)

Area of triangle ABC

$$= \frac{1}{2} \times \text{Base} \times \text{Height}$$

$$= \frac{1}{2} \times 12 \times \sqrt{(20)^2 - (12)^2}$$

$$= \frac{1}{2} \times 12 \times 16 = 96 \text{ sq unit}$$

Area of triangle ACD

$$= \frac{\sqrt{3}}{4} (20)^2 = 173 \text{ sq. unit}$$

∴ Area of quadrilateral ABCD

$$= \text{Area of ABC} + \text{Area of ACD}$$

$$= (173 + 96) \text{ sq. units} = 269 \text{ sq. units}$$

□□□□

Mensuration & Solid Geometry



Practice Exercise: II

1. A tank 16 m long and 12 m wide contains water. How many cubic metres of water must be rushed into it to make the surface rise by

$$16\frac{2}{3} \text{ cm?}$$

(a) 48 m^3

(b) 40 m^3

(c) 32 m^3

(d) 42 m^3

2. The area of three adjacent faces of a rectangular box are p, q and r square cm. The volume of the box is given by

(a) $(p+q+r) \text{ cm}^3$

(b) $\sqrt{pqr} \text{ cm}^3$

(c) $(pqr)^{1/3} \text{ cm}^3$

(d) $pqr \text{ cm}^3$

3. How many bricks are required to build a wall 15m long 3 m high and 50 cm thick, if each brick measures 25 cm by 12 cm by 6 cm.

(a) 16500

(b) 14500

(c) 12500

(d) 10500

4. The diagonal of a cubical box is $\sqrt{300}$ cm. Find the surface area.

(a) $600\sqrt{3} \text{ cm}^2$

(b) 600 cm^2

(b) 1200 cm^2

(d) $900\sqrt{3} \text{ cm}^2$

5. The length of a room is 12 meters, width 8 meters, height 6 metres. How many boxes will it hold if each is allowed 1.5 cubic metre of space?
 (a) 864 (b) 506
 (c) 384 (d) 436
6. If 210 cu m of sand be thrown into a tank 12 m long and 5 m wide, find how much the water will rise?
 (a) 3.5 m (b) 4 m
 (c) 7 m (d) Data inadequate
7. A cu m of metal weighing 90 kg is rolled into a square bar 9 metre long. An exact cube is cut off from the bar. How much does it weigh?
 (a) $5\frac{2}{3}$ kg (b) $6\frac{1}{3}$ kg
 (c) $3\frac{1}{3}$ kg (d) $4\frac{2}{3}$ kg
8. A cube of edge 6 cm is melted and smaller cubes of edge 2 cm each are formed; how many such cubes are possible?
 (a) 39 (b) 24
 (c) 27 (d) 21
9. A rectangular tank is 30 m long 20 m broad. Water is being flown into it through a square pipe of side 5cm. What is the speed of water if the level of water in the tank rises by 1 m in 8 hours?
 (a) 30 km/hr (b) 36 km/hr
 (c) 40 km/hr (d) none of these
10. Three cubes of metal whose edges are in the ratio 3 : 4 : 5 are melted into a single cube, the length of whose diagonal is whose $48\sqrt{3}$ m. Calculate the edges of the three cubes.
 (a) 24m, 32m, 40m (b) 40m, 32m, 24m
 (c) 30m, 22m, 18m (d) 48m, 36m, 24m
11. Two cubes have volumes in the ratio 1 : 27. The ratio of the area of the face of one to that of the other is
 (a) 1 : 2 (b) 1 : 3
 (c) 1 : 6 (d) 1 : 9
12. A cube of edge 3 cm of iron weighs 12 gm. What is the weight of a similar cube of iron whose edge is 12 cm?
 (a) 768 gm (b) 678 gm
 (c) 964 gm (d) 864 gm
13. A 4 cm cube is cut into 1 cm cubes. What is the ratio of surface area of small cubes to that of the large cube?
 (a) 1 : 16 (b) 2 : 3
 (c) 4 : 1 (d) 6 : 1
14. A cubical metallic tank whose each edge measures 30 cm, is completely filled with water. If 2.7 litres water is taken out of it, what will be the depth of remaining water in tank?
 (a) 37 cm (b) 27 cm
 (c) 17 cm (d) None of these
15. 1496 cm^3 of a metal is used to cast a pipe of length 28 cm. If the internal radius of the pipe is 8 cm, the outer radius of the pipe is
 (a) 7 cm (b) 9 cm
 (c) 10 cm (d) 12 cm
16. A sphere is melted to form a cylinder whose height is 4.5 times its radius, what is the ratio of radii of sphere to the cylinder?
 (a) 3 : 2 (b) 4 : 3
 (c) 3 : 5 (d) 2 : 3
17. A brick measure $20 \text{ cm} \times 10 \text{ cm} \times 7\frac{1}{2} \text{ cm}$. How many bricks will be required for a wall 25 m long, 2 m high and $\frac{3}{4}$ m thick?
 (a) 25000 (b) 35000
 (c) 20000 (d) 45000
18. The radius of the cylinder is made twice as large. How should the height be changed so that the volume remains the same?
 (a) $\frac{1}{2}$ × height of original cylinder

- (b) $\frac{1}{4}$ × height of original cylinder
- (c) $\frac{1}{4}\pi r^2$
- (d) none of these
19. A roller is 120cm long and has diameter 84 cm. If it takes 500 complete revolutions to level a playground, determine the cost of levelling at the rate of 30 paise per sq. m. (Use $\pi = \frac{22}{7}$)
- (a) Rs. 475.40 (b) Rs. 375.45
(c) Rs. 375.20 (d) Rs. 475.20
20. Sum of the length, width and depth of a cuboid is s and its diagonal is d . Its surface area is
- (a) s^2 (b) d^2
(c) $s^2 - d^2$ (d) $s^2 + d^2$
21. A hemisphere of lead and of radius 6 cm, is cast into a right circular cone of height 75 cm. The radius of the base of the cone is
- (a) 1.4 cm (b) 2.4 cm
(c) 1.6 cm (d) 3.2 cm
22. From a solid right circular cylinder with height 10 cm and radius of the base 6 cm; a right circular cone of the same height and base is removed. The volume (in cm^3) of the remaining solid is
- (a) 377 (b) 754.3
(c) 1131 (d) none of these
23. A rectangular piece of paper is 22 cm long and 10 cm wide. A cylinder is formed by rolling the paper along its length. The volume of the cylinder is
- (a) 225π cu cm (b) 385 cu cm
(c) 25π cu cm (d) none of these
24. If the radius of a cylinder is doubled and the height is halved, what is the ratio between the new curved surface area and the previous curved surface area of the cylinder
- (a) 1 : 1 (b) 2 : 1
(c) 3 : 2 (d) 2 : 3
25. The material of solid cone is converted into the shape of solid cylinder of equal radius. If the height of the cylinder is 5 cm, what is the height of the cone?
- (a) 25 cm (b) 15 cm
(c) 20 cm (d) 10 cm
26. A spherical ball of lead, 3 cm is diameter is melted and re-cast into three spherical balls. The diameter of two of these are 1.5 cm and 2 cm, respectively. The diameter of the third ball is
- (a) 2.66 cm (b) 2.5 cm
(c) 3 cm (d) 3.5 cm
27. The radii of a cylinder and a cone are equal. If the height of the cylinder is equal to the slant height of the cone then the ratio of the curved surfaces of cylinder and the cone is
- (a) 1 : 1 (b) 2 : 1
(c) 3 : 1 (d) 4 : 1
28. Two cm of rain has fallen on a sq km of land. Assuming that 50% of the raindrops could have been collected and contained in a pool having a 100m × 10m base, by what level would the water level in the pool have increased?
- (a) 15 m (b) 20 m
(c) 10 m (d) 25 m
29. A solid consists of a circular cylinder with an exact fitting right circular cone placed on the top. The height of the cone is h . If the total volume of the solid is the three times the volume of the cone, then the height of the cylinder is
- (a) $2h$ (b) $4h$
(c) $\frac{2h}{3}$ (d) $\frac{3h}{2}$
30. The curved surface of a circular cylinder of height ' h ' and the slant surface of the cone of slant height ' $2h$ ' having the same circular base are in the ratio of
- (a) 1 : 1 (b) 1 : 2
(c) 3 : 2 (d) 1 : 3

31. Find the length of the canvas 2 m in width required to make conical tent 12 m in diameter and 6.3 m in slant height.
 (a) 118.8 m (b) 62.4 m
 (c) 59.4 m (d) 112.4 m
32. If the base radius of a cone is increased by 20% and its slant height is made double, then by how much percent will the area of its curved surface be increased?
 (a) 140% (b) 160%
 (c) 130% (d) 180%
33. A rectangular sheet of area 264 cm^2 and width 11 cm is rolled along its breadth to make a hollow cylinder. The volume of the cylinder is
 (a) 231 c.c. (b) 230 c.c.
 (c) 235 c.c. (d) 234 c.c.
34. If the radius of a sphere is doubled then its volume is increased by
 (a) 100% (b) 200%
 (c) 700% (d) 800%
35. The height of a cylinder is decreased by 8%, keeping its radius unchanged. What is the percentage change in its volume?
 (a) 8% increase (b) 12% decrease
 (c) 8% decrease (d) none of these

Solutions

1. Ans. (c)

$$\begin{aligned} \text{Volume of water} &= 16 \times 12 \times \frac{16\frac{2}{3}}{100} \text{ m}^3 \\ &= 16 \times 12 \times \frac{50}{3 \times 100} \text{ m}^3 \\ &= 32 \text{ m}^3. \end{aligned}$$

2. Ans. (b)

Let the sides of the box be x , y and z
 Then $p=xy$, $q=yz$, $r=zx$
 Volume of the box = xyz
 We have,

$$p \times q \times r = xy \times yz \times zx = x^2y^2z^2$$

$$\text{or } xyz = \sqrt{pqr}.$$

3. Ans. (c)

Number of bricks

$$\begin{aligned} &= \frac{\text{Volume of the wall}}{\text{Volume of the brick}} \\ &= \frac{1500 \text{ cm} \times 300 \text{ cm} \times 50 \text{ cm}}{25 \text{ cm} \times 12 \text{ cm} \times 6 \text{ cm}} \\ &= 12500 \text{ cm}. \end{aligned}$$

4. Ans. (b)

5. Ans. (c)

Capacity of room = $12 \times 8 \times 6 \text{ cu m}$
 Required number of boxes

$$= \frac{12 \times 8 \times 6}{1.5} = 384.$$

6. Ans. (a)

Let the initial height be h and the height after sand is thrown be H metres.

We have to find $H - h$.

According to question,

$$12 \times 5 \times (H - h) = 210$$

$$\therefore H - h = \frac{210}{60} = \frac{7}{2} = 3.5 \text{ metres.}$$

7. Ans. (c)

$$\begin{aligned} (\text{Area of the square end}) \times 9 &= \text{Volume.} \\ &= 1 \text{ m}^3 \end{aligned}$$

$$\therefore \text{Side of the square end} = \sqrt{\frac{1}{9}} \text{ m} = \frac{1}{3} \text{ m}$$

$$\therefore \text{Volume of this cube} = \left(\frac{1}{3}\right)^3 \text{ m}^3 = \frac{1}{27} \text{ m}^3$$

$$\therefore \text{Weight of this cube} = \frac{1}{27} \times 90 \text{ kg} = 3\frac{1}{3} \text{ kg.}$$

8. Ans. (c)

Number of cubes

$$= \left(\frac{\text{Original length of edge}}{\text{New length of edge}} \right)^3$$

$$\therefore \text{Number of cubes} = \left(\frac{6}{2}\right)^3 = 27.$$

9. Ans. (a)

Volume of water collected in the tank in 8 hours

$$= 30\text{m} \times 20\text{m} \times 1\text{m} = 600 \text{ cu m.}$$

\therefore Volume of water collected in the tank in

$$1 \text{ hour} = \frac{600}{8} = 75 \text{ cu m.}$$

Water comes through a pipe of cross-section

$$= 5 \text{ cm} \times 5 \text{ cm} = \frac{25}{10000} \text{ sq. m.}$$

The speed of water = Distance travelled by the water in the pipe in one hour

$$= \frac{75 \times 10000}{25} \text{ m} = 30 \text{ km/hr.}$$

10. Ans. (a)

Since the edges of the cubes are in the ratio 3 : 4 : 5, let these be 3k, 4k, 5k metres, respectively.

Their volumes are $27k^3$, $64k^3$, $125k^3$, cu m.

Thus, the volume of the single cube

$$= (27+64+125)k^3 \text{ cu m.}$$

$$= 216k^3 = (6k)^3 \text{ cu m}$$

We know that the length of the diagonal of a cube of side x is $\sqrt{3}x$. Therefore, the length of the diagonal of the single cube mentioned above is equal to $6k\sqrt{3}$. But the length of the diagonal of this cube is given to be $48\sqrt{3}$, hence

$$6k\sqrt{3} = 48\sqrt{3} \text{ or } k=8.$$

Therefore, the length of the edges of the three cubes are 3×8 , 4×8 , 5×8 m, that is 24m, 32m, 40m.

11. Ans. (d)

$$a_1^3 : a_2^3 = 1 : 27$$

$$\Rightarrow a_1 : a_2 = 1 : 3$$

$$\therefore \text{required ratio is } 1^2 : 3^2 = 1 : 9.$$

12. Ans. (a)

Ratio of the edge of cubes

$$= 3 : 12 = 1 : 4$$

$$\text{Ratio of their volumes} = 1^3 : 4^3 = 1 : 64.$$

Because volume of the new cube is 64 times the volume of the first cube, the weight of the new cube is also 64 times the weight of the first cube.

Weight of the new cube

$$= 64 \times 12\text{gm} = 768 \text{ gm}$$

13. Ans. (a)

14. Ans. (b)

Volume of the cubical metallic tank

$$= l \times b \times h$$

$$= 30 \times 30 \times 30 = 27000 \text{ cm}^3$$

\therefore Volume of water in the tank

$$= \frac{27000}{1000} = 27 \text{ litre } [\because 1 \text{ litre} = 1000 \text{ cm}^3]$$

\therefore Volume of remaining water = 24.3 litre

$$= 243000 \text{ cm}^3$$

$$\text{Now, } l \times b \times h = 243000$$

$$\Rightarrow 30 \times 30 \times h = 243000$$

$$\Rightarrow h = 27 \text{ cm.}$$

15. Ans. (b)

Let the outer radius be x cm

Then, we have

$$1496 = \pi \times (28) \times (x^2 - 8^2)$$

$$\Rightarrow x^2 - 8^2 = \frac{1496 \times 7}{22 \times 28} = 17$$

$$\text{or, } x^2 = 17 + 64 = 81$$

$$\therefore x = 9 \text{ cm}$$

16. Ans. (a)

Let the radius of the sphere and cylinder be 'R' and 'r', respectively.

Volume of the cylinder

$$= \pi r^2 h = \pi r^2 \left(\frac{9}{2}r\right) \quad \left(\because h = \frac{9}{2}r\right) = \frac{9}{2}\pi r^3$$

$$\text{Volume of the sphere} = \frac{4}{3}\pi R^3$$

$$\Rightarrow \frac{4}{3}\pi R^3 = \frac{9}{2}\pi r^3$$

$$\Rightarrow \frac{R^3}{r^3} = \frac{27}{8}$$

$$\Rightarrow \frac{R}{r} = \frac{3}{2}$$

17. Ans. (a)

$$\text{Volume of wall} = 25 \times 2 \times \frac{3}{4} \text{ cu m.}$$

$$\text{Volume of one brick} = \frac{20}{100} \times \frac{10}{100} \times \frac{15}{200}$$

$$= \frac{3}{2000} \text{ cm}$$

Required number of bricks

$$= \left(25 \times 2 \times \frac{3}{4}\right) \div \frac{3}{2000} = 25000.$$

18. Ans. (b)

$$r \rightarrow 2r, \quad h \rightarrow \frac{1}{4}h, \text{ then}$$

$$\text{Volume} = \pi(2r)^2 \times \frac{1}{4}h = \pi r^2 h.$$

19. Ans. (d)

$$r = \frac{84}{2} \text{ cm} = \frac{21}{50} \text{ m,}$$

$$h = 120 \text{ cm} = \frac{120}{100} \text{ m} = \frac{6}{5} \text{ m}$$

The levelled area in one revolution of the roller

$$= \text{curved surface} = 2\pi rh$$

$$= 2 \times \frac{22}{7} \times \frac{21}{50} \times \frac{6}{5} = \frac{396}{125} \text{ sq. m.}$$

The levelled area in 500 revolutions

$$= \frac{396}{125} \times 500 = 1584 \text{ sq. m.}$$

$$= \text{Cost} = .30 \times 1584 = 475.2 \text{ Rs.}$$

20. Ans. (c)

$$l + b + h = s \text{ and } \sqrt{l^2 + b^2 + h^2} = d$$

$$\text{So, } l^2 + b^2 + h^2 = d^2$$

$$\therefore (l + b + h)^2 = s^2$$

$$\Rightarrow l^2 + b^2 + h^2 + 2(lb + bh + hl) = s^2$$

$$\Rightarrow d^2 + 2(lb + bh + hl) = s^2$$

$$\Rightarrow 2(lb + bh + hl) = s^2 - d^2$$

$$\therefore \text{Surface area} = s^2 - d^2$$

21. Ans. (b)

Let r cm be the radius of base of cone

$$\frac{2}{3}\pi(6)^3 = \frac{1}{3}\pi r^2 \times 75$$

$$\therefore r^2 = \frac{2 \times 216}{75} = \frac{2 \times 72}{25}$$

$$\therefore r = \frac{12}{5} = 2.4 \text{ cm.}$$

22. Ans. (b)

Required volume

$$= \text{Volume of cylinder} - \text{Volume of cone}$$

$$= \pi \times 6^2 \times 10 - \frac{1}{3} \times \pi \times 6^2 \times 10$$

$$= \frac{2}{3} \times \pi \times 36 \times 10$$

$$= \frac{2}{3} \times \frac{22}{7} \times 360 = \frac{5280}{7}$$

$$= 754.3 \text{ cu cm.}$$

23. Ans. (b)

Rolled along with its length, then $h = 10$ cm, and the other side = 22 cm

$$\therefore V = \frac{10 \times (22)^2 \times 7}{4 \times 22} = 385 \text{ cm}^3.$$

24. Ans. (a)

Let the initial radius and height of the cylinder be r cm and h cm, respectively.

Then, curved surface area of the original cylinder = $2\pi rh$ and curved surface area of the new cylinder

$$= 2\pi(2r) \times \frac{h}{2} = 2\pi rh$$

$$\therefore \text{Required ratio}$$

$$= \frac{\text{New curved surface area}}{\text{Previous curved surface area}}$$

$$= \frac{2\pi rh}{2\pi rh} = 1 : 1.$$

25. Ans. (b)

Volume of the cylinder = 3 times volume of the cone. This is valid if base and height is the same. Radius is the same, so the height of cone is 3 times the height of the cylinder

$$\therefore \text{Height of the cone} = 3 \times 5 \text{ cm} = 15 \text{ cm.}$$

26. Ans. (b)

$$\frac{4}{3}\pi r^3 = \frac{4}{3}\pi \times \left\{ \left(\frac{3}{2}\right)^3 - \left[\left(\frac{3}{4}\right)^3 + 1^3\right] \right\}$$

$$\therefore r^3 = \frac{125}{64} = \left(\frac{5}{4}\right)^3$$

$$\therefore r = \frac{5}{4}$$

$$\therefore \text{Diameter} = 2r = 2 \times \frac{5}{4} = \frac{5}{2} = 2.5 \text{ cm.}$$

27. Ans. (b)

Let the height and radius of the cylinder be h and r , respectively.

Curved surface of the cylinder = $2\pi rh$ and, curved surface of the cone

$$= \pi r l = \pi r h \quad (h = l)$$

$$\therefore \text{Required ratio} = 2 : 1$$

28. Ans. (c)

Volume of rain water

$$= \text{Area} \times \text{Height} = (1 \text{ km})^2 \times 2 \text{ cm}$$

$$= (1000 \text{ m})^2 \times 0.02 \text{ m} = 20000 \text{ m}^3$$

Quantity of collected water

$$= 50\% \text{ of } 20000 \text{ m}^3$$

$$= \frac{1}{2} \times 20000 = 10000 \text{ m}^3$$

\therefore Increased level in pool

$$= \frac{\text{Volume collected}}{\text{Base area of pool}}$$

$$= \frac{10000}{10 \times 100} = 10 \text{ m}$$

\therefore The water level would be increased by 10 m.

29. Ans. (c)

Let the height of the cylinder be H and its radius = r

$$\text{Then, } \pi r^2 H + \frac{1}{3} \pi r^2 h = 3 \times \frac{1}{3} \pi r^2 h$$

$$\therefore \pi r^2 H = \frac{2}{3} \pi r^2 h \text{ or } H = \frac{2}{3} h.$$

30. Ans. (a)

Curved surface area of cylinder = $2\pi rh$

Slant surface area of the cone
 $= \pi r l = \pi \times r \times 2h = 2\pi r h$
 \therefore Ratio of the two surface areas
 $= 2\pi r h : 2\pi r h = 1 : 1$.

31. Ans. (c)

Curved surface of the tent $= \pi r l$

$$= \frac{22}{7} \times 6 \times 6.3 \text{ m}^2 = 118.8 \text{ m}^2$$

\therefore Length of the canvas

$$= \frac{118.8}{2} \text{ m} = 59.4 \text{ m}$$

32. Ans. (a)

Radius of the cone

$$= r + 20\% \text{ of } r = 1.2 r$$

and, slant height $= 2l$

\therefore Surface area of the new cone

$$= 2\pi \times 1.2 r \times 2l$$

$$= 2\pi \times 2.4 rl$$

Increase in surface area

$$= 2\pi \times 2.4 rl - 2\pi rl$$

$$= 2\pi \times 1.4 rl$$

Percentage increase

$$= \frac{2\pi \times 1.4 rl}{2\pi rl} \times 100 = 140\%$$

Therefore, surface area of the cone will be increased by 140%.

33. Ans. (a)

$$\text{Length of the sheet} = \frac{264}{11} = 24 \text{ cm}$$

When the sheet is rolled along its breadth, the width of the sheet will be equal to the circumference of the cylinder and the length of the sheet will be height of the cylinder.

\therefore Radius of cylinder formed

$$= \frac{11}{2\pi} = \frac{11}{2} \times \frac{7}{22} = \frac{7}{4} \text{ cm}$$

Volume of the cylinder

$$= \pi r^2 h = \frac{22}{7} \times \frac{7}{4} \times \frac{7}{4} \times 24 = 231 \text{ c.c.}$$

34. Ans. (c)

$$\text{Original volume} = \frac{4}{3} \pi r^3$$

$$\text{New volume} = \frac{4}{3} \pi (2r)^3 = \frac{32}{3} \pi r^3$$

Increase %

$$= \left(\frac{28}{3} \pi r^3 \times \frac{3}{4\pi r^3} \times 100 \right) \% = 700\%$$

35. Ans. (c)

Here, $x = y = 0$ and $z = -8$.

\therefore Percentage change in volume

$$= \left[x + y + z + \frac{xy + yz + zx}{100} + \frac{xyz}{(100)^2} \right] \%$$

$$= \left[0 + 0 - 8 + \frac{0 \times 0 + 0 \times (-0.8) + 0 \times (-0.8)}{(100)^2} \right] \%$$

$$= -8\%$$

\therefore Volume of the cylinder decreases by 8%.

□□□□

Trigonometry



Practice Exercise : I

- The angle of elevation of a moon when the length of the shadow of a pole is equal to its height, is

(a) 30°	(b) 45°
(c) 60°	(d) none of these

- The upper part of a tree broken by the wind makes an angle of 30° with the ground and the distance from the root to the point where the top of the tree touches the ground is 10m. What was the height of the tree?
 (a) $10\sqrt{3}$ (b) $10/\sqrt{3}$
 (c) $20\sqrt{3}$ (d) None of these
- In a rectangle, if the angle between a diagonal and a side is 30° and the length of diagonal is 6 cm, the area of the rectangle is
 (a) 9 cm^2 (b) $9\sqrt{3}\text{ cm}^2$
 (c) 27 cm^2 (d) 36 cm^2
- When the length of the shadow of a pole is equal to the height of the pole, then the elevation of source of light is
 (a) 30° (b) 45°
 (c) 60° (d) 75°
- From the top of a light house 60 m high with its base at sea level, the angle of depression of a boat is 15° . The distance of the boat from the light house is
 (a) $60\left(\frac{\sqrt{3}-1}{\sqrt{3}+1}\right)\text{m}$ (b) $60\left(\frac{\sqrt{3}+1}{\sqrt{3}-1}\right)\text{m}$
 (c) $30\left(\frac{\sqrt{3}-1}{\sqrt{3}+1}\right)\text{m}$ (d) $30\left(\frac{\sqrt{3}+1}{\sqrt{3}-1}\right)\text{m}$
- The angle of elevation of the top of an unfinished tower at a point distant 120m from its base is 45° . If the elevation of the top at the same point is to be 60° , the tower must be raised to a height
 (a) $120(\sqrt{3}+1)\text{m}$ (b) $120(\sqrt{3}-1)\text{m}$
 (c) $10(\sqrt{3}+1)\text{m}$ (d) none of these
- A person walking along a straight road towards a hill observes at two points,

distance $\sqrt{3}$ km, the angles of elevation of the hill to be 30° and 60° . The height of the hill is

- (a) $\frac{3}{2}$ km (b) $\sqrt{\frac{2}{3}}$ km
 (c) $\frac{\sqrt{3}+1}{2}$ km (d) $\sqrt{3}$ km

- A man is standing on the 8 m long shadow of a 6 m long pole. If the length of the shadow is 2.4m, then the height of the man is
 (a) 1.4 m (b) 1.6 m
 (c) 1.8 m (d) 2.0 m

Solutions

- Ans. (b)

Let $AB = x$.

Then, $AC = x$

$$\therefore \tan \theta = \frac{AB}{AC} = 1$$

$$\Rightarrow \theta = 45^\circ.$$

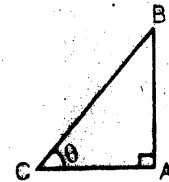

- Ans. (a)

Solution Let QMP be the tree. When broken by the wind its top P strikes the ground at A such that $\angle QAM = 30^\circ$, $AQ = 10\text{ m}$ and $MA = MP$.

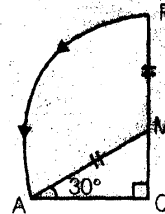

$$\frac{MQ}{AQ} = \tan 30^\circ \Rightarrow MQ = \frac{10}{\sqrt{3}}\text{ m}$$

$$\text{and, } \frac{AM}{AQ} = \sec 30^\circ$$

$$\Rightarrow AM = 10\left(\frac{2}{\sqrt{3}}\right) = \frac{20}{\sqrt{3}}$$

\therefore Height of the tree

$$= QM + MP = QM + AM = \frac{10}{\sqrt{3}} + \frac{20}{\sqrt{3}}$$

$$= \frac{30}{\sqrt{3}} = 10\sqrt{3} \text{ m.}$$

3. Ans. (b)

Let ABCD be the rectangle in which $\angle BAC = 30^\circ$ and $AC = 6$ cm.

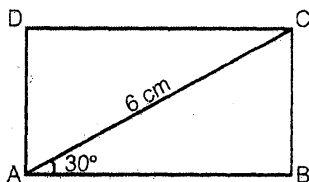

$$\frac{AB}{AC} = \cos 30^\circ = \frac{\sqrt{3}}{2} \Rightarrow AB = 3\sqrt{3} \text{ cm.}$$

$$\frac{BC}{AC} = \sin 30^\circ = \frac{1}{2} \Rightarrow BC = 3 \text{ cm.}$$

$$\therefore \text{Area of the rectangle} \\ = AB \times BC = 9\sqrt{3} \text{ cm}^2.$$

4. Ans. (b)

$$\text{Since } \frac{h}{x} = \tan \theta \text{ and } h = x.$$

$$\therefore \tan \theta = 1 \Rightarrow \theta = 45^\circ$$

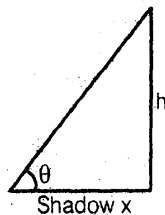

5. Ans. (b)

Here, B is the position of boat and AC is light house.

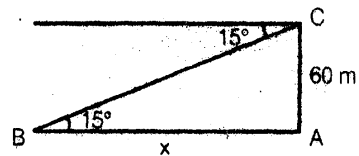

$$\text{Now, } \frac{AC}{x} = \tan 15^\circ = \tan(45^\circ - 30^\circ)$$

$$= \frac{1 - \tan 30^\circ}{1 + \tan 30^\circ} = \frac{1 - \frac{1}{\sqrt{3}}}{1 + \frac{1}{\sqrt{3}}}$$

$$\therefore x = 60 \left(\frac{\sqrt{3} + 1}{\sqrt{3} - 1} \right) \text{ m.}$$

6. Ans. (b)

$$\frac{h+x}{120} = \tan 60^\circ = \sqrt{3}$$

$$h+x = \sqrt{3}(120).$$

$$\text{Also, } \frac{h}{120} = \tan 45^\circ = 1.$$

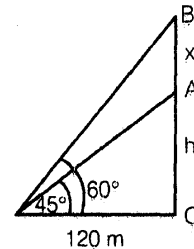

$$\therefore h = 120 \text{ m} \quad \therefore 120 + x = 120\sqrt{3}$$

$$\therefore x = 120(\sqrt{3} - 1) \text{ m.}$$

7. Ans. (a)

$$\frac{h}{x} = \tan 60^\circ = \sqrt{3}. \quad \therefore h = \sqrt{3}x.$$

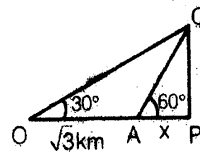

$$\text{Also, } \frac{h}{\sqrt{3}+x} = \tan 30^\circ = \frac{1}{\sqrt{3}}$$

$$\therefore \sqrt{3}h = \sqrt{3} + x$$

$$\therefore \sqrt{3}(\sqrt{3}x) = \sqrt{3} + x \text{ or } 3x - x = \sqrt{3}$$

$$\therefore 2x = \sqrt{3} \quad \therefore x = \frac{\sqrt{3}}{2}$$

$$\therefore h = \sqrt{3} \cdot \frac{\sqrt{3}}{2} = \frac{3}{2} \text{ km.}$$

8. Ans. (c)

Let h be the height of the man.

$$\therefore \frac{6}{8} = \frac{h}{2.4} \Rightarrow h = \frac{3}{4}(2.4) = 1.8 \text{ m.}$$

□□□□

C

Section

Reasoning & Data Interpretation





Blood Relationship

Some Standard Coding Technique

1. Proper noun should always be denoted by capital letters

e.g. John, Merry and Paul can be codes as John - J, Merry - M, Paul - P

2. In questions where the sex of proper noun is crucial to the solving of questions, you can denote the female by under lining the capital letter used

ex → Merry is a beautiful girl Merry - M

ex → Sheena is the only girl student in her class Sheena - S

3. Relationship:

a) Is the Son of

ex → Ram is the son of Mr. Pratap → $\begin{matrix} P \\ R \end{matrix}$

b) Is the daughter of

ex → Sweta is daughter of Mr Pratap → $\begin{matrix} P \\ S \end{matrix}$

c) Is the Parent of

ex → A is the parent of B → $\begin{matrix} A & A \\ B & \text{or} & B \end{matrix}$

d) Is the spouse of

ex → A is spouse of B → A — B or B — A
[Note: Here sex of A & B is not mentioned]

ex → Seema is wife of Rahul → R - S

ex → Priya is wife of Rajesh R - P

[Note: It is better to write male on the left & female on the right hand side to avoid any confusion]

e) Is the sibling of

ex → A is sibling of B

1. A .. B or (A & B are brothers)
2. A .. B or (A is sister of B)
3. A .. B or (B is sister of A)
4. A .. B or (A & B are sisters)

f) Grand father, Grand son relation

ex → Ramesh & Param are the two sons of Mr Shiv Kumar, who is the son of Mr Sundarlal

$\begin{matrix} Su \\ \rightarrow Sk \\ R..P \end{matrix}$

(Note: Shiv Kumar and Sundarlal are coded as Sk and Su to avoid any confusion)

g) Where the sex of a person is not confirmed write it in a box

like Q is the only son of S

(Here Q is male but sex of

Q S is not mentioned)

□□□□

Direction (Qs. 7 to 12): Read the information carefully and answer the below it.
Q is the son of six members P, Q, Y is the son of R but R is not mother of P, Z is the brother of Y.
(c) Brother
(d) Uncle
can't be determined
u.s?

Questions

Direction (Qs. 1 to 6): Read the following information carefully and answer the question below it.

All the six members of a family P, Q, R, S, T and U are travelling together Q is the son of R but R is not the mother of Q, P and R are a married couple. T is the brother of R. S is the daughter of P. U is the brother of Q.

1. How many male members are there in the family?
 - (a) 1
 - (b) 2
 - (c) 3
 - (d) 4
2. Who is the mother of Q?
 - (a) S
 - (b) U
 - (c) T
 - (d) P
3. How many children does P have?
 - (a) One
 - (b) Two
 - (c) Three
 - (d) Four
4. Who is the wife of T?
 - (a) P
 - (b) U
 - (c) Q
 - (d) can't be determined
5. Which of the following is a pair of females?
 - (a) PT
 - (b) QS
 - (c) SU
6. How is

7. Who is the brother-in-law of R?
 - (a) P
 - (b) Z
 - (c) Y
 - (d) X
8. Who is the father of Q?
 - (a) R
 - (b) P
 - (c) Z
 - (d) none of these
9. How many children does P have?
 - (a) One
 - (b) Two
 - (c) Three
 - (d) Four
10. How many female member are there in the family?
 - (a) One
 - (b) Two
 - (c) Three
 - (d) Four
11. How is Q related to X?
 - (a) Husband
 - (b) Father
 - (c) Brother
 - (d) Uncle
12. Which is a pair of brothers?
 - (a) P and X
 - (b) P and Z
 - (c) Q and X
 - (d) R and Y

Direction (Qs. 13 to 15) : Read the following information carefully and answer the questions given below it

P is the son of Q, R, Q's sister has a son S and daughter T. U is the maternal uncle of S.

13. How is P related to S?
 - (a) Cousin
 - (b) Nephew
 - (c) Uncle
 - (d) Brother
14. How is T related to U?
 - (a) Sister
 - (b) Daughter
 - (c) Niece
 - (d) Wife
15. How many nephew does U have?
 - (a) Nil
 - (b) One
 - (c) Two
 - (d) Three
16. Ranjan is the brother of Sachin and Manick is the father of Ranjan. Jagat is the brother of Priya and Priya is the daughter of Sachin. Who is the uncle of Jagat?
 - (a) Ranjan
 - (b) Sachin
 - (c) Manick
 - (d) None of these

wing
stion

Y

T.. R - P
Q.. U .. S

- 1. (d)
- 2. (d)
- 3. (c)
- 4. (d)
- 5. (d)
- 6. (b)

Sol. (7 - 12)

Y.. R - P .. Z
Q .. X

- 7. (b)
- 8. (a)
- 9. (b)
- 10. (b)
- 11. (c)
- 12. (d)

Sol.(13 to 15)

Q .. X .. U
P S .. T

Here (Let X is sister of Q)

- 13. (a)
- 14. (c)
- 15. (c)

Sol.(16)

M
R .. S
P .. J

- 16. (a)

Sol.(17 - 18)

A - E H
C .. B - G
E D

- 17. (c)

- 18. (a) here sex of C is not confirmed

Sol.(19 to 23)

P, Q, R, S, T

- There are two father & two son it means relation is Grandfather, father - son
- Engineer is wife of teacher Tea — Engg
Teacher is son of Painter

Painter
→ Tea

I is a female and wife of Painter

Painter - I
Tea - Engg
R

- R is youngest
It means R is Son of Tea
- S is eldest, it means S is the grandfather

Painter — I
(S)
Tea — Engg
(Q) — P
R

now complete tree is like this

S - I
Q - P
R

- 19. (b)
- 20. (b)
- 21. (b)
- 22. (a)
- 23. (b)

Sol.(24 to 28)

- (i). A - B .. L

d₁ ... d₂
d₁ & d₂ are daughter of A

- (ii) I .. K, J is consine of I

- (iii) E & F are husband of d₁ & d₂

E — d₁ .. d₂ — F

d₁ .. d₂ .. S_{1}, d₃ .. S_{3}}}

- (iv) G & H are (d₁ & d₂) daughters of C, so naturally C is wife of E because only E has two daughters

- (v) Now complete tree is

A - B .. L
E - C D - F
↓ ↓
H .. G .. J, I .. K

- 24. (c)
- 25. (b)
- 26. (a)
- 27. (b)
- 28. (d)
- 28. (d)

□□□□



Coding and Decoding

Direction (Qs. 1 to 5): Read the following information carefully and answer the question below it.

- If 'Rat is called Dog', 'Dog is called Mongoose', 'Mongoose is called Lion', 'Lion is called Snake' and 'Snake is called Elephant', which animal is reared as pet?
(a) Rat (b) Dog
(c) Mongoose (d) Lion
- If Finger is called Toe, Toe is called Foot, Foot is called Thumb, Thumb is called Ankle, Ankle is called Palm and Palm is called Knee, which one finger has different name?
(a) Thumb (b) Ankle
(c) Knee (d) Palm
- In a certain code language, 'kew xas huma deko' means 'she is eating apples', 'kew tepo qua' means 'she sells toys' and 'su lim deko' means 'I like apples'. Which word in that language means she and apples?
(a) xas & deko (b) xas & kew
(c) kew & deko (d) kew & xas
- If 'gnr tag zog qmp' stands for 'Seoul Olympic Organising Committee', 'hydo gnr emf' stands for 'Summer Olympic Games' and 'esm sdr hyto' stands for 'Modern Games History', which would be the code for Summer?
(a) hyto (b) gnr
(c) emf (d) zog
- In a certain code language, 'Pat Zoo Sim' means 'Eat Good Mangoes', 'Pus Sim Tim' means 'Mangoes and Sweets' and 'Tim Zoo Kit' means 'Purchase Good sweets', which word in the language means Good?
(a) Zoo (b) Pus
(c) Sim (d) Tim

Direction (Qs. 6 to 10): Read the following information carefully and answer the question below.

Δ means 'is greater than', $\%$ means 'is lesser than', \square means 'is equal to', $=$ means 'is not equal to', $+$ means 'is a little more than', \times means 'is a little less than'.

- If $a \Delta b$ and $b + c$, then
(a) $a \% c$ (b) $c \% a$
(c) $c + a$ (d) can't say
- If $c = a$ and $a = b$, then
(a) $b \Delta a$ (b) $c \square a$
(c) $b = a$ (d) can't say
- If $a \times b$ and $b \square c$, then
(a) $c + a$ (b) $b \Delta c$
(c) $a + c$ (d) $c \square a$
- If $c \% b$ and $b \times a$, then
(a) $a \Delta c$ (b) $c \square a$
(c) $b \Delta c$ (d) $c \Delta a$

10. If $ac + bc$ then

- (a) $a \square c$ (b) $b \Delta c$
 (c) $c \Delta b$ (d) $b \% a$

Direction (Qs. 11 to 15): Read the following information carefully and answer the question below it.

If $>$ denotes $+$, $<$ denotes $-$, $+$ denotes \div , \wedge denotes \times , $-$ denotes $=$, \times denotes $>$ and $=$ denotes $<$, choose the correct statement in each of the following questions.

11. (a) $6 + 3 > = 4 + 2 < 1$
 (b) $4 > 6 + 2 \times 3 2 + 4 < 1$
 (c) $8 < 4 + 2 = 6 > 3$
 (d) $14 + 7 > 3 = 6 + 3 > 2$
12. (a) $14 > 18 + 9 = 16 + 4 < 1$
 (b) $4 > 3 \wedge 8 < 1 - 6 + 2 > 24$
 (c) $3 < 6 \wedge 4 > 25 = 8 + 4 > 1$
 (d) $12 > 9 + 3 < 6 \times 25 + 5 > 6$
13. (a) $13 > 7 < 6 + 2 = 3 \wedge 4$
 (b) $9 > 5 > 4 - 18 + 9 > 16$
 (c) $9 < 3 < 2 > 1 \times 8 \wedge 2$
 (d) $28 + 4 \wedge 2 = 6 \wedge 4 + 2$
14. (a) $29 < 18 + 6 = 36 + 6 \wedge 4$
 (b) $18 > 12 + 4 \times 7 > 8 \wedge 2$
 (c) $32 > 6 + 2 = 6 < 7 \wedge 2$
 (d) $31 > 1 < 2 = 4 > 6 \wedge 7$
15. (a) $7 > 7 < 7 + 7 = 14$
 (b) $7 \wedge 7 > 7 + 7 = 7 \wedge 7 > 1$
 (c) $7 < 7 + 7 = 6$
 (d) $7 + 7 > 7 = 8$

Direction (Qs. 16 to 18): Read the following information carefully and answer the question below it.

In a certain code, 'il be pee' means 'roses are blue'; 'silk hee' means 'red flowers' and 'pee mit hee' means 'flowers are vegetables'.

16. How is 'red' written in that code?

- (a) hee (b) silk
 (c) be (d) none of these

17. How is 'roses' written in that code?

- (a) il
 (b) pee
 (c) be
 (d) can not be determined

18. How is 'vegetables are red flowers' written in this code?

- (a) pee silk mit hee
 (b) silk pee hee be
 (c) il silk mit hee
 (d) can not be determined

Direction (Qs. 19 to 22): Read the following information carefully and answer the question below it.

Shamita is very found of collecting greeting cards. Her collection of 211 cards has a good mix of Birthday cards, New year cards, Deepawali cards, Christmas cards and even a Marriage Anniversary card. The number of Birthday cards is equal to the sum of all other except the Marriage Anniversary card. The number of New Year card is double of Deepawali cards which in turn is double of Christmas cards.

19. The number of Birthday cards in the collection is :

- (a) 95 (b) 105
 (c) 110 (d) 85

20. The number of Deepawali cards is :

- (a) 25 (b) 30
 (c) 35 (d) 40

21. The number of Christmas cards is :

- (a) 10 (b) 15
 (c) 20 (d) 25

22. The ratio of Birthday cards to Christmas cards is :

- (a) 7 (b) 4
 (c) 2 (d) 1

Direction (Qs. 23 to 28): Read the following information carefully and answer the question below it.

Rahul's roll number in IES Exam is a number consisting of three non-zero distinct digits, such that the sum of the digits at hundred's and unit's place is equal to that half of the digit at ten's place. Also the sum of all possible three digit numbers obtained using these three digits without repetition is 2664.

23. The digits in the unit is :

- (a) 2 (b) 1
(c) 3 (d) Can't say

24. The digits in the tens place is :

- (a) 6 (b) 8
(c) 9 (d) 2

25. The digit in the hundreds place is :

- (a) 3 (b) 6
(c) 9 (d) Can't say

26. The sum of the three digits is :

- (a) 7 (b) 12
(c) 10 (d) 14

27. The three digit number is :

- (a) 138 (b) 183
(c) 381 (d) Can't say

28. The three digit is number is always divisible by :

- (a) 3 (b) 18
(c) 29 (d) none of these

Direction (Qs. 29 to 30): Read the following information carefully and answer the question below it

P, Q, R, S, T, U and V are seven positive integers and $(P \times Q \times R \times S \times T \times U \times V)$ is odd.

29. Maximum how many of these integers can be odd?

- (a) 4 (b) 5
(c) 6 (d) 7

30. Minimum how many of these integers can be even?

- (a) 3 (b) 2
(c) 4 (d) 0

31. In the following sequence of alphabets, which letter would be eight to the right of the letter which is sixteenth from the left ?

- (a) G (b) Y
(c) Z (d) X

32. CEGJLN ____ XZB. The missing group of letters in the series are ...

- (a) QSU (b) NPR
(c) PRT (d) TUX

Direction (Qs. 33 to 37): Read the following information carefully and answer the question below it.

In each of the Letter Analogy various terms of a letter series are given with one term missing as shown by (?). Choose the missing term out of the given alternatives.

33. HUA GIZ FSY EAX ?

- (a) DWQ (b) DQW
(c) WDQ (d) WQD

34. DF GJ KM NQ RT ?

- (a) UW (b) YZ
(c) XZ (d) UX

35. DCXW FEVU HGTS ?

- (a) LKPQ (b) ABZ
(c) JIRQ (d) LMRS

36. AB DEF HIJK ? STUVWX

- (a) MNOPQ (b) LMNOP
(c) LMNO (d) QRSTU

37. C G L R ?

- (a) Y (b) S
(c) U (d) Z

□□□□

Solutions

Answer 1 to 5:

1. (c) 'Dog' is reared as pet. But 'Dog' is called 'Mongoose'. So, a 'Mongoose' is reared as pet.
2. (b) The 'Thumb' is a finger having a different name. But 'Thumb' is called 'Ankle'. So, 'Ankle' is the finger that has a different name.
3. (c) In the 1st and 2nd statements, the common code word is kew and the common word is she. So, kew means she. In the 1st and 2nd statements, the common code is deko and the common word is apples. So, deko means apples.
4. (c) In the first and second statements, the common code word is gnr and the common word is Olympic. So, gnr means Olympic. In the second and third statements, the common code is hyto and the common word is games. So, hyto means games. Thus, in the second statement, emf means summer.
5. (a) From 1st and 3rd statements. Zoo means Good.

Answer 6 to 10:

6. (b) $a \Delta b$ and $b + c \Rightarrow a > b$ and b is a little more than $c \Rightarrow a > c \Rightarrow c < a$ i.e. $a < c \% a$.
7. (c) $c = a$ and $a = b \Rightarrow c \neq a$ and $a \neq b \Rightarrow b \neq a$ i.e. $b = a$.
8. (a) $a \times b$ and $b \square c \Rightarrow a$ is a little less than b and $b = c$.
 $\Rightarrow a$ is a little less than c .
 $\Rightarrow c$ is a little more than a i.e. $c + a$.
9. (a) $c \%$ and $b \times a \Rightarrow c < b$ and b is a little less than a .
 $\Rightarrow c < a \Rightarrow a > c$ i.e. $a \Delta c$.
10. (d) $ac + bc \Rightarrow ac > bc \Rightarrow a > b \Rightarrow b < a$ i.e. $b \% a$.

Answer 11 to 15 :

11. (c) Using the proper notations in (3), we get the statements as $8 - 4 + 2 < 6 + 3$ or $6 < 9$, which is true.
12. (b) Using the proper notations in (2), we get the statements as $4 + 3 \times 8 - 1 = 6 \div 2 + 24$ or $27 = 27$.
13. (b) Using the proper notations in (2), we get the statements as $9 + 5 + 4 = 18 + 9 + 16$ or $18 = 18$.
14. (d) Using the proper notations in (4), we get the statements as $31 + 1 - 2 < 4 + 6 \times 7$ or $30 < 46$.
15. (a) Using the proper notations in (1), we get the statements as $7 + 7 - 7 \div 717$ or $13 < 14$.

Answer 16 to 18:

16. (a) In the second and third statements, the common code word is 'hee' and the common word is 'flowers'. So, 'hee' stands for 'flowers'. Thus, in the second statement, 'silk' stands for 'red'.
17. (d) Since from the given information, we can only find the code for 'are' in the first statement, it cannot be determined which of the remaining two codes for 'roses'.
18. (a) Clearly, the required code will consist of the same codes as in the third statements with the code for 'red' added to it.

Answer 19 to 22:

If, number of Christmas cards = x
 Then, number of Deepawali cards = $2x$
 Number of New Year cards = $4x$
 and number of Birthday cards
 $= x + 2x + 4x$
 $= 7x$

$$\text{i.e. } 7x + (x + 2x + 4x) + 1 = 211$$

$$14x = 210$$

$$x = 15$$

Thus, number of Birthday cards

$$= 15 \times 7$$

$$= 105$$

Number of New Year cards

$$= 15 \times 4$$

$$= 60$$

Number of Deepawali cards

$$= 15 \times 2$$

$$= 30$$

Number of Christmas cards

$$= 15 \times 1$$

$$= 15$$

Number of Marriage Anniversary card

$$= 1$$

$$\text{Total} = 211$$

19. (b)

20. (b)

21. (b)

22. (a)

Answer 23 to 28:

Let the digit be x, y, z such that the number is $100x + 10y + z$

Thus, the other five 3 digit we may obtained using these 3 digit will be

$$100x + 10z + y$$

$$100y + 10x + z$$

$$100y + 10z + x$$

$$100z + 10x + y$$

$$100z + 10y + x$$

Now when we add all the six three digit number possible to be formed by these three digits:

$$222(x + y + z) = 2664 \text{ or } x + y + z = 12$$

$$\text{Also } x + z = y/2 \text{ thus } y = 8$$

$$\text{Thus, } x + z = 4$$

As the digits are non zero and distinct thus x and z have to be 1 and 3 but not necessarily in the same order. Thus we cannot say whether the number is 183 or 381.

23. (d)

24. (b)

25. (d)

26. (b)

27. (d)

28. (a)

Answer 29 to 32:

29. (d)

30. (d)

31. (d)

32. (a)

Answer 33 to 37:

33. (b) All the letters of each term are moved one step backward to obtain the corresponding letters of the next term.

34. (d) There is a gap of one letter between both the letters of first term, a gap of two letters between both the letters of second term and again a gap of one and two letters between the letters of third and fourth terms respectively. Besides, the last letter of each term and the first letter of next term are in alphabetical.

35. (c) First two letters of each term are in reverse order. Similarly third and fourth letters are also in reverse order. Besides, the second letter of each term is the letter next to the first letter of the proceeding term.

36. (a) The number of letters in the term goes on increasing by 1 at each step. Each term consists of letters in alphabetical. The last letter of each term and the first letter of the next term are alternate.

37. (a) There is a gap of three letters between the first and the second term, four letters between the second and the third term; and the letter between the third and the fourth term. So, there should be a gap of six letters between the fourth term and the missing term.

□□□□



Cubes

Cube is a type of cuboid in which all the sides i.e. length, breadth and height are equal.

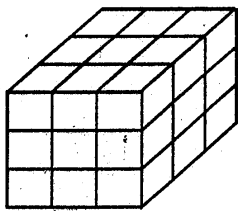

Fig. 1

In the above Fig. (1) total number of cube = $n^3 = 3^3 = 27$.

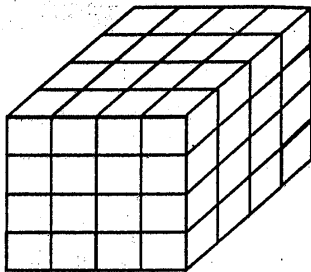

Fig. (2)

In the above Fig. (2) total number of small cubes will be $n^3 = 4^3 = 64$.

If a cube of dimension $n \times n \times n$ is painted on all six surface, then smaller cubes formed will have

1. Total number of cubes = n^3
2. Total number of cubes painted on three sides = 8
3. Cubes painted on two sides = $(n - 2) \times 4 \times 3$
4. Cubes painted on single side = $(n - 2)^2 \times 6$
5. Cubes painted on no sides = $(n - 2)^3$.

Case I when $n = 3$

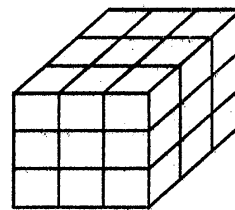

Fig. 3

In the above Fig. (3)

1. Total number of cubes = $n^3 = 3^3 = 27$
2. Total number of cubes painted on three sides = 8.

3. Total number of cubes painted on two sides $(n - 2) \times 4 \times 3$
 $= (3 - 2) \times 4 \times 3 = 12$
4. Cubes painted on single side
 $(n - 2)^2 \times 6 = (3 - 2)^2 \times 6 = 6$
5. Cubes painted on no sides
 $= (n - 2)^3 \Rightarrow (3 - 2)^3 = 1.$

Case II

When $n = 4$

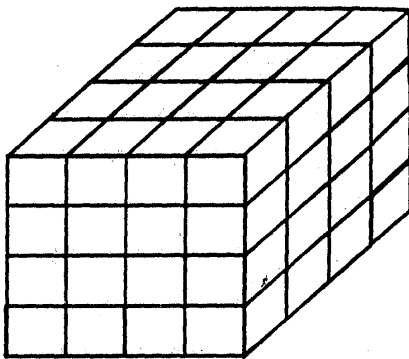

Fig. (4)

In the above Fig. (4)

1. Total number of cubes $\Rightarrow n^3 = 4^3 = 64$
2. Total number of cubes painted on three sides = 8
3. Total number of cubes painted on two sides $= (n - 2) \times 4 \times 3 = (4 - 2) \times 4 \times 3 = 24$
4. Total number of cubes painted on single side $= (n - 2)^2 \times 6 = (4 - 2)^2 \times 6 = 24$
5. Cubes painted on no sides
 $= (n - 2)^3 = (4 - 2)^3 = 8$

Case 3

When $n = 5$

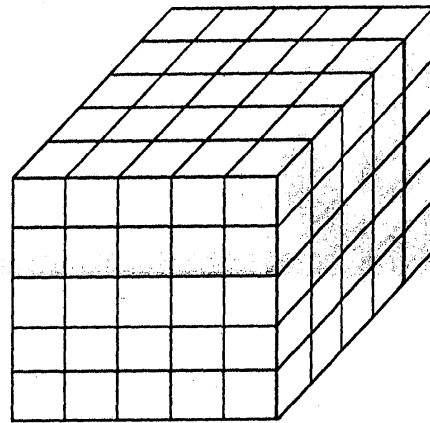

Fig. (5)

In the above Fig. (5)

1. Total number of cubes $= n^3 = 5^3 = 125$
2. Total number of cubes painted on three sides = 8
3. Cubes painted on two sides
 $= (n - 2) \times 4 \times 3 = (5 - 2) \times 4 \times 3 = 36$
4. Cubes painted on single side
 $= (n - 2)^2 \times 6 = (5 - 2)^2 \times 6 = 56.$
5. Cubes painted on no sides
 $= (n - 2)^3 = (5 - 2)^3 = 27.$

Table

		n = 3	n = 4	n = 5	n = 6
1	Number of cubes = n^3	27	64	125	216
2	Three sides painted cubes = 8	8	8	8	8
3.	Two sides painted cubes = $(n - 2) \times 4 \times 3$	12	24	36	48
4	Single sides painted cubes = $(n - 2)^2 \times 6$	6	24	54	96
5	No side painted cubes = $(n - 2)^3$	1	8	27	64

Dices

Dice are cubical structures in which numbers or points from 1 to 6 are marked on sides. Problems based on dices are very simple in nature. Normally there are two cases:

Case I : Sum of numbers on opposite sides is seven.

Naturally the faces opposite to each other will be

1 - 6

2 - 5

3 - 4

Case II : When three different positions of dice is given.

In such cases, first of all we will determine the face which is not adjacent to the given number. That number will naturally be the numbers marked on opposite face.

Ex.1 A dice with its face numbered 1 to 6, is shown in three different positions x, y and z.

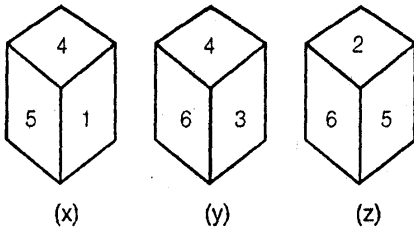

Find opposite faces.

Sol.: Faces adjacent to 6 are

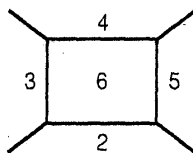

Naturally 1 will be marked opposite to 6.

Faces adjacent to 4, are

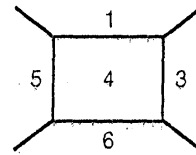

Naturally 2 will be marked opposite to 4.

Thus opposite faces are

6 - 1

4 - 2

3 - 5 Ans.



Practice Exercise: I

Direction (Qs. 1 to 5) : Read the following information carefully and answer the question below it.

A wooden cube is painted red on all the six face base. It is then cut at equal distances at right angle four times vertical (top to bottom) and two times horizontal (along the sides) as shown in the figure. Study the diagram and answer the following questions.

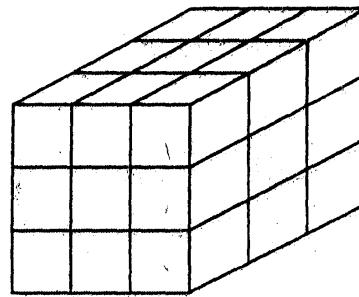

- How many cubes are formed in all ?
 (a) 16 (b) 24
 (c) 27 (d) 32
- How many cubes will have only one face painted in Red?
 (a) 4 (b) 5
 (c) 6 (d) 8

3. How many cubes will have exactly two face painted only in Red?
 (a) 10 (b) 12
 (c) 14 (d) 8
4. How many cubes will have at least three sides painted?
 (a) 8 (b) 6
 (c) 3 (d) 2
5. How many cubes will have no face painted at all?
 (a) 1 (b) 2
 (c) 3 (d) 4

Direction (Qs. 6 to 9) : Read the following information carefully and answer the question below it

Six dice with their upper faces erased are as shown:

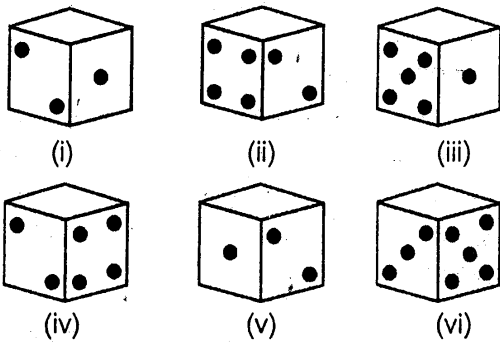

The sum of the number of dots on the opposite faces is 7

6. If the dice (i), (ii) and (iii) have even number of dots on their bottom faces, then what would be the total number of dots on the top faces?
 (a) 14 (b) 7
 (c) 21 (d) 12
7. If dice (i), (ii) and (iii) have even number of dots on their bottom face and the dice (iv), (v) and (vi) have odd number of dots on the top faces, then what would be the difference in the total number of top face dots between these two sets?
 (a) 0 (b) 1
 (c) 2 (d) 3
8. If odd numbered dice have odd number of dots on their bottom faces, what would be the total number of dots on the top faces of these dice?
 (a) 4 (b) 6
 (c) 10 (d) 12
9. If even numbered dice have even number of dots on their top faces, what would be the total number of dots on the top faces of these dice?
 (a) 18 (b) 14
 (c) 12 (d) 10

Direction (Qs. 10 to 14): Read the following information carefully and answer the question below it.

A dice with its face numbered 1 to 6, is shown in three different position X, Y and Z

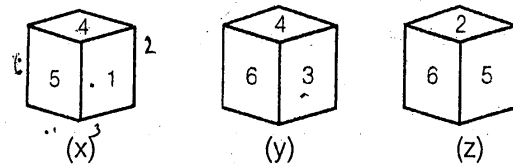

10. Which number lies at the bottom face of dice X?
 (a) 1 (b) 2
 (c) 3 (d) 4
11. Which number lies at the bottom face of dice Y?
 (a) 6 (b) 5
 (c) 2 (d) 1
12. Which number lies opposite of 6?
 (a) 1 (b) 2
 (c) 4 (d) 5
13. Which numbers are hidden behind the numbers 6 and 5 in the dice Z?
 (a) 1 & 4 (b) 1 & 3
 (c) 4 & 3 (d) 1 & 2
14. Which of the hidden number adjacent to 5 in die X are common to the hidden numbers adjacent to 5 in die Z?
 (a) 1 & 4 (b) 2
 (c) 6 (d) none

Direction (Qs. 15 to 18): Read the following information carefully and answer the question below it.

A dice is prepared in following manner

- (i) 1 should lie between 2 and 3
- (ii) 2 should lie opposite to the 3
- (iii) 4 should lie between 5 and 6
- (iv) 5 and 6 should lie opposite to each other
- (v) 4 should face down

15. The face opposite to 1:

- (a) 2
- (b) 4
- (c) 6
- (d) 5

16. The upper face is:

- (a) 1
- (b) 6
- (c) 2
- (d) 5

17. The face adjacent to 5 are:

- (a) 2, 6, 1, 4
- (b) 1, 3, 4, 6
- (c) 1, 4, 2, 3
- (d) 2, 3, 4, 6

18. The face adjacent to 3 are:

- (a) 5, 4, 1, 2
- (b) 1, 2, 5, 6
- (c) 5, 6, 4, 1
- (d) 2, 6, 4, 5

Direction (Qs. 19 to 22): Read the following information carefully and answer the question below it.

Six dice with their upper faces erased are as shown:

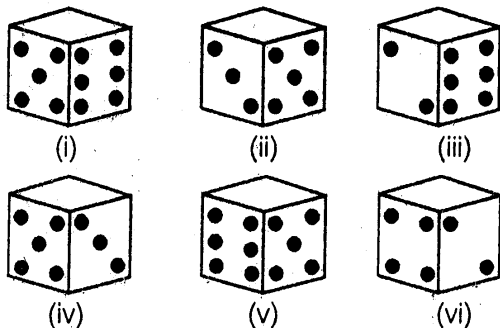

The sum of the number of dots on the opposite faces is 7.

19. If the dice (i), (ii), (iii) have even number of dots on their bottom faces, than what would

be the total number of dots on the top faces?

- (a) 14
- (b) 7
- (c) 21
- (d) 12

20. If dice (i), (ii), (iii) have even number of dots on their bottom faces and the dice (iv), (v), (vi) have odd number of dots on their top faces then what would be the difference in the total number of top face between these two sets?

- (a) 0
- (b) 1
- (c) 2
- (d) 3

21. If odd numbered dice have odd number on their bottom faces what would be the total number of dots on the top faces of these dice?

- (a) 4
- (b) 6
- (c) 10
- (d) 12

22. If even numbered dice have even number of dots on their top faces what would be the total number of dots on the top faces of these dice?

- (a) 18
- (b) 14
- (c) 12
- (d) 10

Direction (Qs. 23 to 32): Read the following information carefully and answer the question below it

A solid cube of each side 8 cms, has been painted red, blue and black on pairs of opposite faces. It is then cut into cubical blocks of each side 2 cms.

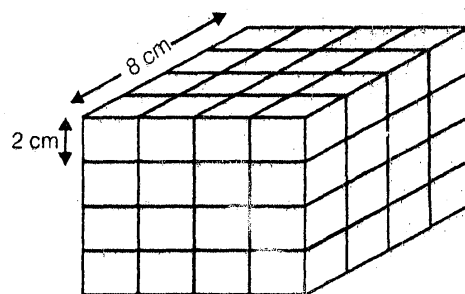

23. How many cubes have no face painted ?

- (a) 0
- (b) 4
- (c) 8
- (d) 12

24. How many cubes will have only one face painted?
 (a) 8 (b) 16
 (c) 24 (d) 28
25. How many cubes will have only two face painted?
 (a) 8 (b) 16
 (c) 20 (d) 24
26. How many cubes will have three faces painted?
 (a) 0 (b) 4
 (c) 6 (d) 8
27. How many cubes will have three faces painted with different colours?
 (a) 0 (b) 4
 (c) 8 (d) 12
28. How many cubes will have two faces painted red & black and all other faces unpainted
 (a) 4 (b) 8
 (c) 16 (d) 32
29. How many cubes have only one face red and all other faces unpainted ?
 (a) 4 (b) 8
 (c) 12 (d) 16
30. How many cubes have two faces painted black?
 (a) 2 (b) 4
 (c) 8 (d) none
31. How many cubes have one face painted blue and one face painted red ? (The other faces may be painted or unpainted)
 (a) 16 (b) 12
 (c) 8 (d) 0
32. How many cubes are there in all ?
 (a) 64 (b) 56
 (c) 40 (d) 32



Solutions

Answer 1 to 5:

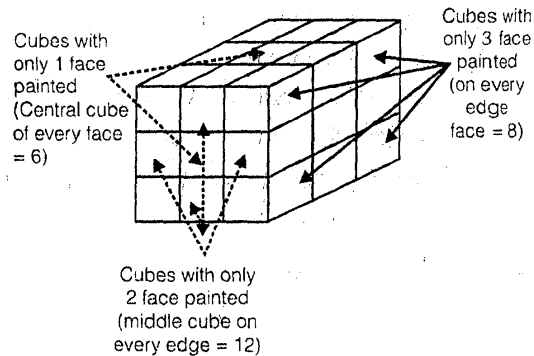

And there will be a cube in the centre of these 26 (8 + 12 + 6) visible cubes. Which have none of its face painted. Hence the total no. of cubes = 9 in each of three layers = 8 + 12 + 6 + 1 = 27

1. (c)
2. (c)
3. (b)
4. (a)
5. (a)

Answer 6 to 9:

6. (b) Since in figure (i), (ii) and (iii), even number of dots lie at the bottom, so odd number of dots lie at the top. Thus 3, 1 and 3 occur at the top. Their sum is 7.
7. (c) Since in figure (i), (ii) and (iii), even number of dots lie at the bottom, so odd number of dots lie at the top. Thus 3, 1 and 3 occur at the top. Their sum is 7. In figure (iv), (v) and (vi), since odd number of dots appear on the top faces, so their top faces have 1, 3 and 1 dots respectively. Their sum is 5. Therefore the difference of the total number of top face dots = 7 - 5 = 2.
8. (d) Odd number dice are (i), (iii) and (v). Since they had odd numbers on their bottom faces, so their are even numbers on their top faces, i.e., the numbers 4, 4 and 4 lie on their top faces. Their sum is 12.

9. (a) Even number dice are (ii), (iv), and (vi). They have even numbers, i.e., 6, 6, and 6 on their top faces. Their sum is 18.

Answer 10 to 14:

- From fig (X) & (Y), it is clear that the numbers 5, 1, 6 and 3 cannot appear opposited 4. So, 2 lies opposite 4. Obviously, 3 lies opposite 5.
10. (c) Since 5 lies at the top of dice (x) and 3 lies opposite 5, so 3 lies at the bottom face of dice (x).
11. (c) Since 4 lies at the top of dice (y) and 2 lies opposite 4, so 2 lies at the bottom face of dice (y)
12. (a) As discussed earlier, 1 lies opposite 6.
13. (b) The numbers which are hidden behind the numbers 6 and 5 in dice (z) are the numbers lying opposite 5 and 6 i.e. 3 and 1
14. (d) In fig (x), the hidden number behind the numbers 5 are 6 and 2 and in dice (z) numbers lying adjacent to 5 are 1 and 4 hence, common number are none.

Answer 15 to 18:

15. (b) The face opposite to 1 will be 4

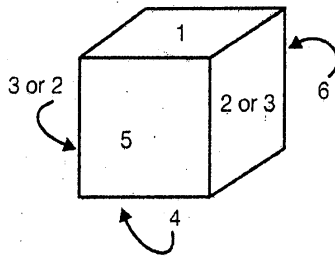

16. (a) The top face must be 1 as 4 is in the bottom
17. (c) 6 is opposite to 5 hence 1, 2, 3, 4 must be adjacent to 5
18. (c) 3 is opposite to 3 hence 1, 4, 5, 6 must be adjacent to 3.

Answer 19 to 22:

Since the total number of dots on the opposite faces is 7, so, 1 lies opposite 6, 2 lies opposite 5; 3 lies opposite 4. In

fig (i), since numbers 5 and 6 are visible, so 2 and 1 are hidden behind them. Hence, 3 and 4 should lie on the top & bottom. Similarly, in other figures, the top and bottom numbers are : fig, (ii) : 6 and 1; fig. (iii) : 3 and 4; fig (iv): 6 and 1; fig (v) : 3 and 4; fig (vi) : 6 and 1.

19. (b) Since, in figures (i), (ii) and (iii), even number of dots lie at the bottom, so odd number of dots lie at the top. Thus, the numbers 3, 1 and 3 occur at the top. Their sum is 7.
20. (c) Since, in figures (i), (ii) & (iii), even number of dots lie at the bottom, so odd number of dots lie at the top. Thus, 3, 1 and 3 dots lie at the top faces. Their sum is 7. Also, in figures (iv), (v) & (vi), since odd number of dots appear on the top faces, so their top face have 1, 3, and 1 dots respectively. Their sum is 5. The difference in the total number of top face dots = $7 - 5 = 2$
21. (d) Odd numbered dice are (i), (iii) & (v). Since they have had odd numbers on their bottom faces, so their are even numbers on their top faces, i.e. the numbers 4, 4 and 4 lie on their top faces. Their sum is 12
22. (a) Even numbered dice are (ii), (iv) & (vi). They have even numbers i.e. 6, 6 and 6 on their top faces. Their sum is 18

Answer 23 to 32:

23. (c) Four central cubes in layer II and four central cube in layer II have no face painted. Thus, there are 8 such cubes
24. (c) There are 4 cubes in layer 1, 8 cubes in layer II, 8 cubes in layer III and 4 cubes in layer IV which have only one face painted. Thus, there are $4 + 8 + 8 + 4 = 24$ such cubes.
25. (d) There are 8 cubes in layer 1, 4 cubes in layer II, 4 cubes in layer II and 8 cubes in layer IV which have only two face painted. Thus, there are $8 + 4 + 4 + 8 = 24$ such cubes.

26. (d) Four corner cubes in layer I and four corner cubes in layer IV have three face painted. Thus, there are 8 such cubes.
27. (c) Four corner cubes in layer I and four corner cubes in layer IV have three face painted with different colours. Thus there are 8 such cubes.
28. (b) There are four cubes in layer I and four cubes in layer IV which have two faces painted red and black and all other faces unpainted. Thus, there are 8 such cubes.
29. (b) There are four cubes in layer I and four cubes in layer IV which have only one face painted red and all other faces unpainted. Thus, there are 8 such cubes
30. (d) There can be no cubes which has two of its faces both painted with the same colour
31. (a) There are $4 + 4 = 8$ cubes in layer I and $4 + 4 = 8$ cubes in layer IV which have one face painted blue and one face painted red. Thus, there are 16 such cubes.
32. (a) There are four layers of 16 cubes each. Thus, there are $16 \times 4 = 64$ cubes in all.

□□□□



Direction Sense Test

- A man is facing south. He turns 135° in the anticlockwise direction and then 180° in the clockwise direction. Which direction is he facing now?
(a) North-east (b) North-west
(c) South-east (d) South-west
- A man is facing north-west. He turns 90° in the clockwise direction and then 135° in the anticlockwise direction. Which direction is he facing now?
(a) East (b) West
(c) North (d) South
- Rakesh starts walking straight towards east. After walking 75 metres, he turns to the left and walks 25 metres straight. Again he turns to the left, walks a distance of 40 metres straight, again he turns to the left and walks a distance of 25 metres. How far is he from the starting point?
(a) 25 metres (b) 50 metres
(c) 140 metres (d) none of these
- A man leaves for his office from his house. He walks towards East. After moving a distance of 20 m, he turns towards South and walks 10 m. Then he walks 35 m towards the West and further 5 m towards the North. He then turns towards East and walks 15 m. What is the straight distance in metres between his initial and final positions?
(a) 0
(b) 5
(c) 10
(d) cannot be determined
(e) none of these
- Vinod walks 20 metres towards North. He then turns left and walks 40 metres. He again turns left and walks 20 metres. Further, he moves 20 metres after turning to the right. How far is he from his original position?
(a) 20 metres (b) 30 metres
(c) 50 metres (d) 60 metres
(e) none of these
- Kuldeep starts from his house towards West. After walking a distance of 30 metres, he turned towards right and walked 20 metres. He then turned left and moving a distance of 10 m turned to his left and walked 40 metres, turns to the left and walks 5 metres. Finally he turns to his left. In which direction is he walking now?
(a) North (b) South
(c) East (d) South-West
(e) west
- A rat runs 20' towards East and turns a right, runs 10' and turns to right, runs 9' and again turns to left, runs 5' and then turns to left, runs 12' and finally turns to left and runs 6'. Now, which direction is the rat facing?
(a) East (b) West
(c) North (d) South

8. A girl leaves from her home. She first walks 30 metres in North-west direction and then 30 m in South-West direction. Next, she walk 30 metres in South-east direction. Finally, she turns towards her house. In which direction is she moving?
(a) North-east (b) North-west
(c) South-east (d) South-west
(e) None of these
9. I am facing South. I turn right and walk 20 m. Then I turn right again and walk 10 m. Then I turn left and walk 10 m and then turning right walk 20 m. Then I turn right again and walk 60 m. In which direction am I from the starting point?
(a) North (b) North-west
(c) East (d) North-east
10. A man walks 1km towards East and then he turns to South and walks 5 km. Again he turns to East and walks 2 km, after this he turns to North and walks 9 km. Now, how far is he from his starting point?
(a) 3 km (b) 4 km
(c) 5 km (d) 7 km
11. From his house Sanjay went 15 kms to the North. Then he turned West and covered 10 kms. Then, he turned South and covered 5 kms. Finally, turning to East, he covered 10 kms. In which direction is he from his house?
(a) East (b) West
(c) North (d) South
12. Going 50 m to the South of her house, Radhika turns left and goes another 20 m. Then, turning to the North, she goes 30 m and then starts walking to her house. In which direction is she walking now?
(a) North-west (b) North
(c) South-east (d) East
13. Rahul walks 20 m North. Then he turns right and walks 30 m. Then he turns right and walks 35 m. Then he turns left and walks 15 m. Then he again turns left and walks 15 m. In which direction and how many metres away is he from his original position?
(a) 15 metres west (b) 30 metres east
(c) 30 metres west (d) 45 metres east
14. A child is looking for his father. He went 90 metres is the East before turning to his right. He went 20 metres before turning to his right again to look for his father at his uncle's place 30 metres from this point. His father was not there. From here he went 100 metres to the North before meeting his father in a street. How far did the son meet his father from the starting point?
(a) 80 metres (b) 100 metres
(c) 140 metres (d) 260 metres
15. The door of Aditya's house faces the East. From the back side of his house, he walk straight 50 metres, then turns to the right and walks 50 metres again. Finally he turns towards left and stops after walking 25 metres. Now, Adity is in which direction from the starting point?
(a) South-east (b) North-east
(c) South-west (d) North-west
16. Two buses start from the opposite points of a main road, 150 kms apart. The first bus runs for 25 kms and takes a right turn and then runs for 15 kms. It then turns left and runs for another 25 kms and takes the direction back to reach the main road. In the meantime, due to a minor breakdown, the other bus has run only 35 kms along the main road. What would be the distance between the two buses at this point?
(a) 65 kms (b) 75 kms
(c) 80 kms (d) 85 kms

17. X and Y start moving towards each other from two places 200 m apart. After walking 60 m, B turns left and goes 20 m, then he turns right and goes 40 m. He then turns right again and comes back to the road on which he had started walking. If A and B walk with the same speed, what is the distance between them now?

- (a) 20 m (b) 30 m
(c) 40 m (d) 50 m

18. Five boys are standing in a row facing East. Deepak is to the left of Sameer, Tushar and Shailendra. Sameer, Tushar and Shailendra are to the left of Sushil. Shailendra is between Sammer and Tushar. If Tushar is fourth from the left, how far is Sameer from the right?

- (a) First (b) Second
(c) Third (d) Fourth
(e) Fifth

19. After walking 6 km, I turned right and covered a distance of 2 km, then turned left and covered a distance of 10 km. In the end, I was moving towards the north. From which direction did I start my journey?

- (a) North (b) South
(c) East (d) West

20. A postman was returning to the post office which was in front of him to the north. When the post office was 100 metres away from him, he turned to the left and moved 50 metres to deliver the last letter at Shantivilla. He then moved in the same direction for 40 metres, turned to his right and moved 100 metres. How many metres was he away from the post office.

- (a) 0 (b) 90
(c) 150 (d) 100
(e) None of these

21. A boy rode his bicycle northwards, then turned left and rode one km and again turned left

and rode 2 km. He found himself exactly one km west of his starting point. How far did he ride northwards initially?

- (a) 1 km (b) 2 km
(c) 3 km (d) 5 km

Direction (Questions 22 to 26): Read the following information carefully and answer the questions given below it:

- (i) Six flat on a floor in two rows facing North and South are allotted to P, Q, R, S, T and U.
(ii) Q gets a North facing flat and is not next to S.
(iii) S and U get diagonally opposite flats
(iv) R, next to U, gets a South facing flat and T gets a North facing flat

22. Which of the following combinations get South facing flats?

- (a) QTS (b) UTP
(c) URP (d) Data inadequate
(e) None of these

23. Whose flat is between Q and S?

- (a) T (b) U
(c) R (d) T
(e) None of these

24. If the flats of T and P are interchanged, whose flat will be next to that of U?

- (a) P (b) Q
(c) R (d) T
(e) None of these

25. The flats of which of the other pairs than SU is diagonally opposite to each other?

- (a) QP (b) QR
(c) PT (d) TS
(e) None of these

26. To arrive at the answers to the above questions, which of the following statements can be dispensed with?

- (a) None (b) (i) only
(c) (ii) only (d) (iii) only
(e) None of these

27. Anuj started walking positioning his back towards the sun. After sometime, he turned left, then turned right and then towards the left again. In which direction is he going now?
 (a) North or South (b) East or West
 (c) North or West (d) South or West

Direction (Question 28 to 32): The following question are based on the diagram given below showing four persons stationed at the four corners of a square piece of plat as shown.

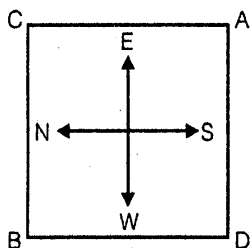

28. A starts crossing the field diagonally. After walking half the distance, he turns right, walks some distance and turns left. Which direction is A facing now?
 (a) North-east (b) North-west
 (c) North (d) South-east
 (e) South-west
29. From the original position given in the above figure, A and B move one arm length clockwise and then cross over to the corner diagonally opposite; C and D move one arm length anti-clockwise and cross over the corner diagonally opposite. The original configuration ADBC has now changed to
 (a) CBDA (b) BDAC
 (c) DACB (d) ABCD
 (e) BCAD
30. From the original position, B and D move one and a half length of sides clockwise and anticlockwise respectively. Which one of the following statements is true?
 (A) B and D are both at the midpoint between A and C
 (B) D is at the midpoint between A and C, and B at the corner originally occupied by A.
 (C) B is at the midpoint between A and C, and D at the corner originally occupied by A.
 (D) B and D are both at the midpoint between A and D.
 (E) B is at the midpoint between A and C, and D at the midpoint between original position of B and C.
31. From the positions in original figure, C and A move diagonally to opposite corners and then one side each clockwise and anticlockwise respectively. B and D move two sides each clockwise and anticlockwise respectively. Where is A now?
 (a) At the north-west corner
 (b) At the north-east corner
 (c) At the south-east corner
 (d) at the south-west corner
 (e) Midway between original position of B and D
32. After the movements given in Q.31 above, who is at the north-west corner?
 (a) A (b) B
 (c) C (d) None of these
33. A square field ABCD of side 90 m is so located that its diagonal AC is from north to south and the corner B is to the west of D. Rohan and Rahul start walking along the sides from B and C respectively in the clockwise and anticlockwise direction with speeds of 8 km/hr and 10 km/hr. Where shall they cross each other the second time?
 (a) On AD at a distance of 30 m from A
 (b) On BC at a distance of 10 m from B
 (c) On AD at a distance of 30 m from D
 (d) On BC at a distance of 10 m from C

Solutions

1. (d) As shown in Fig. 1, the man initially faces in the direction OA. On moving 135° anticlockwise, he faces in the direction OB. On further moving 180° clockwise, he faces in the direction OC, which is South-west.

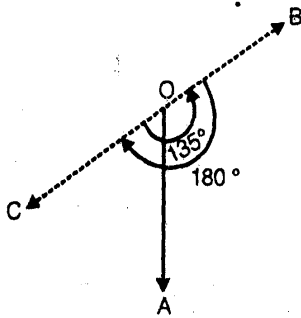

2. (b) As shown in Fig. 2, the man initially faces in the direction OP. On moving 90° clockwise, the man faces in the direction OQ. On further moving 135° anticlockwise, he faces in the direction OR, which is West.

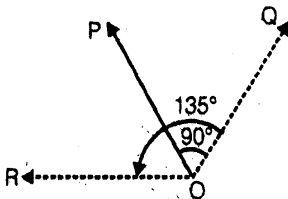

3. (d) The movement of Rakesh are as shown in Fig.

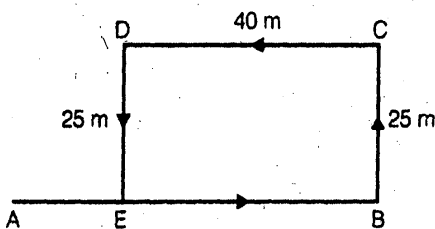

Clearly, $EB = DC = 40$ m.
 \therefore Rakesh's distance from the starting point A $= (AB - EB) = (75 - 40) \text{ m} = 35 \text{ m}$.

4. (b) The movement of the man from A to F are as shown in Fig.

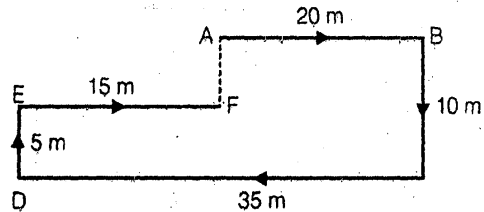

Clearly, $DC = AB + EF$.

\therefore F is in line with A.

Also, $AF = (BC - DE) = 5 \text{ m}$.

So, the man is 5 metres away from his initial position.

5. (d) The movements of Vinod are as shown in Fig.

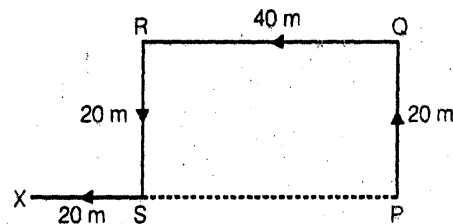

Clearly; Vinod's distance from his initial position $P = PX = (PS + SX) = (QR + SX) = (40 + 20) \text{ m} = 60 \text{ m}$.

6. (a) The movement of Kuldeep are as shown in Fig. from A to G.

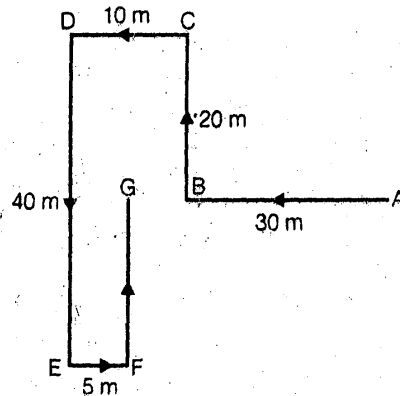

Clearly, Kuldeep is finally walking in the direction FG i.e. North

7. (c) The movements of the rat from A to G are as shown in Fig.

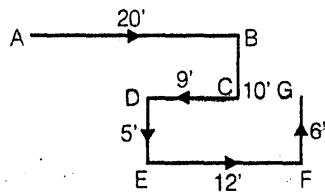

Clearly, it is finally walking in the direction FG i.e, North

8. (a) The movements of the girl are as shown in Fig. (A to B, B to C, C to D, D to A)
Clearly, she is finally moving in the direction DA i.e, North-east

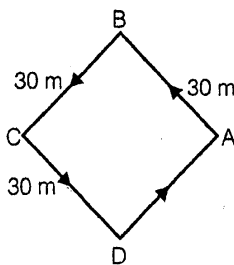

9. (d) The movements of the person are from A to F, as shown Fig. Clearly, the final position is F which is to the North-east for the starting point A

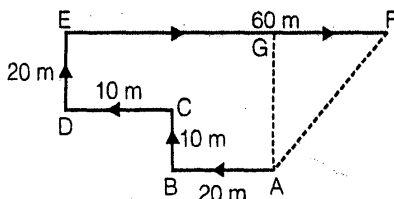

10. (c) The movements of the man are as shown in Fig. (A to B, B to C, C to D, D to E).

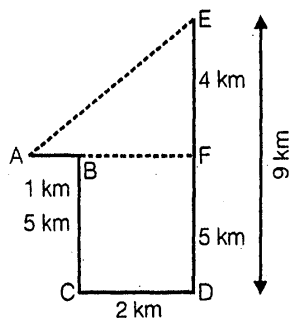

Clearly, $DE - EC = 5 \text{ km}$.
 $EF = (DE - DF) = (9 - 5) \text{ km} = 4 \text{ km}$.
 $BF = CD = 2 \text{ km}$
 $AF = AB + BF = AB + CD = (1 + 2) \text{ km} = 3 \text{ km}$
 \therefore Man's distance from starting point A
 $= AE = \sqrt{AF^2 + EF^2} = \sqrt{3^2 + 4^2}$
 $= \sqrt{25} = 5 \text{ km}$

11. (c) The movements of Sanjay are as shown in Fig. (A to B, B to C, C to D and D to E).

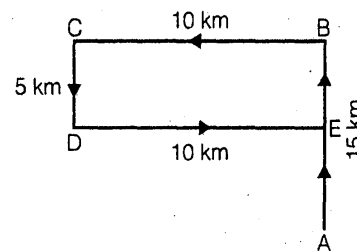

Clearly, his final position is E which is to the North of his house at A.

12. (a) The movements of Radhika are as shown in Fig. (A to B, B, to C, C to D and D to A).

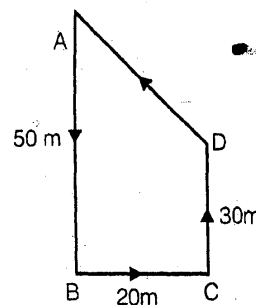

Clearly, she is finally moving in the direction DA i.e. North-west.

13. (d) The movement of Rahul from A to F are as shown in Fig.

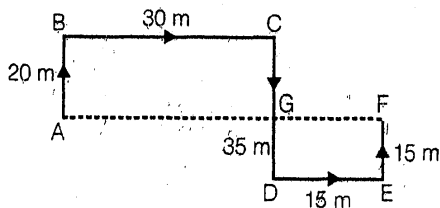

Since $CD = AB + EF$, so F lies in line with A
 \therefore Rahul distance from original position A
 $= AF = (AG + GF)$
 $= (BC + DE) = (30 + 15) = 45 \text{ M.}$

Also, F lies to the east of A

14. (b) The movements of the child from A to E are as shown in Fig.

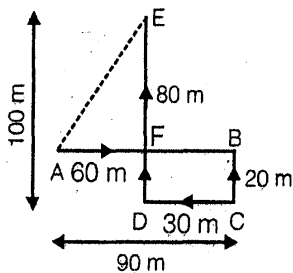

Clearly, the child meets his father at E.
 Now, $AF = (AB - FB) = (AB - DC)$
 $= (90 - 30) \text{ m} = 60 \text{ m.}$
 $EF = (DE - DF) = (DE - BC)$
 $= (100 - 20) \text{ m} = 80 \text{ m.}$

15. (d) Since Aditya's house faces towards East and he walks from backside of his house, it means that he starts walking towards West. Thus, the movements of Aditya are as shown in Fig. (A to B, B, to C, C to D). Clearly, Aditya's final position is D which is to the North-west of the starting point A.

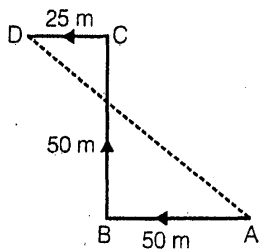

16. (a) Let X and Y be two buses.
 Bus X travels along the path PA, AB, BC, CD
 Now, $AD = BC = 25 \text{ km}$
 Bus Y travels 35 km upto E

$$\therefore \text{Distance between two buses} \\ = PQ - (PD + QE) \\ = [150 - (50 + 35)] = 65 \text{ km}$$

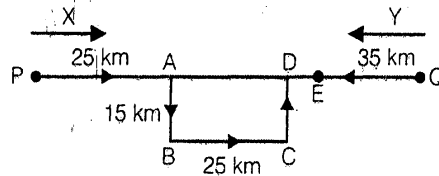

17. (c) Clearly Y moves 60 m from Q upto A, then 20 m upto B, 40 m upto C and then upto D.

$$\text{So, } AD = BC = 40 \text{ m.}$$

$$QD = (60 + 40) \text{ m} = 100 \text{ m.}$$

Since A and B travel with the same speed, A will travel the same speed along the horizontal as B travels in the same time i.e. $(60 + 20) + 40 + 20 = 140 \text{ m.}$

So, X travels 140 m upto A.

$$\therefore \text{Distance between X and Y} = AD \\ = (100 - 60) \text{ m} = 40 \text{ m.}$$

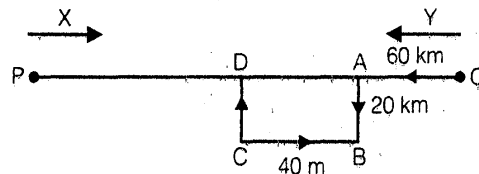

18. (d) Deepak (D) is to the left of Sameer (S), Tushar (T) and Shailendra (Sh) means D, S, T, Sh. Sameer, Tushar and Shailendra are to the left of Sushil (Su) means S, T, Sh, Su, Shailendra is between Sameer and Tushar means S, Sh, T, Tushar is fourth from the left means $\square\square\square T$. Combining all the arrangements, we have D, S, Sh, T, Su, So Sameer is fourth from the right.

19. (b) Clearly, the route is as shown in the adjoining diagram. Thus, the man started

his journey from the South and moved northwards

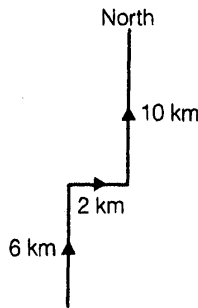

20. (b) Clearly, the route the postman is as shown.

So, at the final point the distance of postman from post office

$$\begin{aligned}
 &= EA = BD \\
 &= BC + CD \\
 &= (50 + 40) = 90 \text{ m.}
 \end{aligned}$$

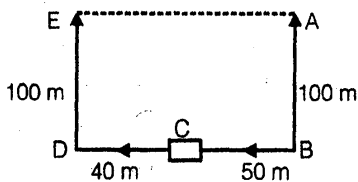

21. (b) Clearly, the boy rode from A to B, to C and finally upto D. Since D lies to the west of A, so required distance

$$= AB = CD = 2 \text{ km}$$

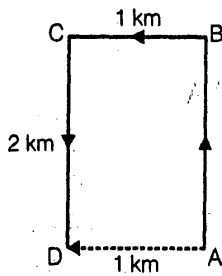

Answer 22 to 26

Q gets a North-facing flat and is not next to S means

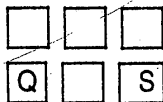

S and U get diagonally opposite flats means

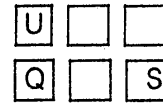

R, next to U, gets a South facing flat and T gets a north facing flat means

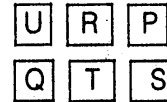

So, the arrangement is:

South facing flats

U	R	P
---	---	---

North facing flats

Q	T	S
---	---	---

- 22. (c) The South facing flats are U, R, P
- 23. (a) T's flat is between Q and S
- 24. (c) The flat next to U's flat is of R, which remains unchanged if the flats of T and P are interchanged
- 25. (a) The diagonally opposite pairs are SU and QP
- 26. (a) Clearly, all the statements are necessary to answer the given questions
- 27. (a) Clearly, there are two possible movements of Anuj as shown below:

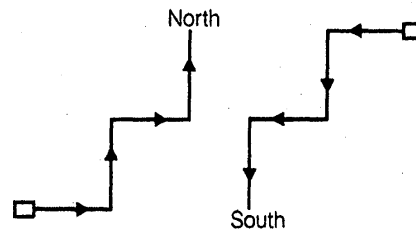

Thus, Anuj is finally moving towards either North or South

28. (b) Clearly, the route of A is as shown
Comparing it with the given diagram,
the direction of A will be north-west

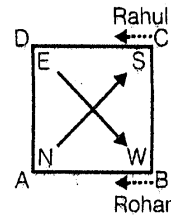

29. (a) Clearly, (i), (ii), (iii) and (iv) show the movements of A, B, C, and D respectively while the new arrangement so obtained is shown in (v). So, the configuration changes to CBDA.

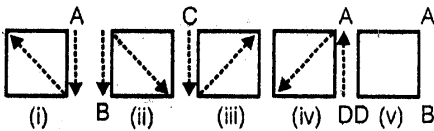

30. (a) The movements of B and D are clearly shown in the adjoining diagram
So, statements (a) is true.

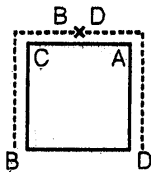

31. (d) The movements of A, C, B, and D are shown in figures (i), (ii), (iii) and (iv) respectively. The final configuration is shown in (v). Comparing (v) with the given diagram, A is in the south-west corner.

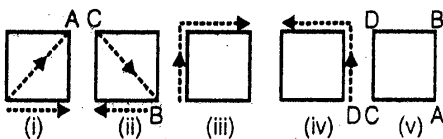

32. (c) Clearly, C is at the north-west corner
33. (d) Clearly, the arrangement is as shown in the adjoining diagram.

$$\text{Rohan's Speed} = 8 \text{ km/hr} = \frac{8000}{60 \times 60}$$

$$\text{m/sec} = \frac{25}{9} \text{ m/sec.}$$

Since Rohan and Rahul are moving in opposite direction, so they together cover

a distance of $\left(\frac{20}{9} + \frac{25}{9}\right)$ i.e., $\frac{45}{9}$ or 5

metres in one second.

To meet at a point, they together have a cover distance $(CD + DA + AB)$ i.e., 270 m. Now, 5 metres is covered in 1 second

So, 270 m will be covered in $\left(\frac{1}{5} \times 270\right)$

$m = 120 \text{ m.}$

Now, distance covered by Rohan in 54

seconds = $\left(\frac{20}{9} \times 54\right) m = 120 \text{ m.}$

Distance covered by Rahul in 54 seconds

= $\left(\frac{25}{9} \times 54\right) m = 150 \text{ m.}$

Thus, Rohan and Rahul meet for the first time on AD at a point 30 m from A and 60 m from D. Now, to meet again, Rohan and Rahul will have to complete one full round i.e., together move a distance of 360 m. 5 metres is covered by both together in 1 second

Thus, 360 m will be covered by both in

$$\left(\frac{1}{5} \times 360\right) = 72 \text{ second.}$$

Now, distance covered by Rohan in

$$72 \text{ seconds} = \left(\frac{29}{9} \times 72\right) \text{ m} = 160 \text{ m.}$$

Distance covered by Rahul in 72 seconds

$$= \left(\frac{25}{9} \times 72\right) \text{ m} = 200 \text{ m.}$$

Thus, Rohan and Rahul meet on BC at a point 10 m from C and 80 m from B.

□□□□



Data Interpretation

Executive member, managers and personnel at different level in the various organizations are require to analyse different sets of datas. Balance sheet, Records of Annual General Meeting, Quarterly Report etc. requires interpretation of various datas. On the basis of the given sets of datas future projections can be made there after corrective action can be taken at regular intervals. Mainly there are following sets to represent datas.

- Graph
- Table
- Bar Diagrams
- Pie Charts
- Miscellaneous Figures etc.

Graph

Graph is the simplest way to represent data. Single set or multiple sets of datas can be shown in a graph.

Normally following things are required to analyse.

- Increase in profit in absolute terms
- Increase in profit in percentage term
- Growth rate of the given duration
- Average annual growth rate
- Average profit
- Capacity utilisation
- In case of trade, Trade Deficit and Trade Surplus etc.

Lets have an example of graph

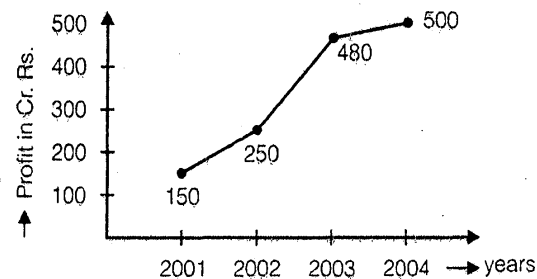

Fig. (I) Balance Sheet of ABC corporation.

On the basis of the given balance sheet of ABC corporation we can calculate following things.

1. Increase in profit in absolute terms
 - The highest absolute increment in profit is observed during financial year 2002-03.
 - The least absolute increment in profit is observed during financial year 2003.04.
2. Percent increase in profit

$$2001-02 \quad \frac{250 - 150}{150} \times 100 = 66.66\%$$

$$2002-03 \quad \frac{480 - 250}{250} \times 100 = 92\%$$

$$2003-04 \quad \frac{500 - 480}{480} \times 100 = 4.16\%$$

- The highest profit increment in percentage term is for financial year 2003-03.
- The minimum profit increment in percentage term is for financial year 2003-04.

3. Growth rate for the duration 2001-04

$$\Rightarrow \frac{500 - 150}{150} \times 100 = 233\%$$

[Growth rate for the duration]

$$= \frac{\text{Final years Profit} - \text{Base years profit}}{\text{Base years profit}}$$

4. Average Annual Growth Rate

$$= \frac{\text{Increase in profit for the duration}}{\text{Base years profit}}$$

$$\times \frac{100}{\text{Number of years}}$$

in the above example

$$\frac{500 - 150}{150} \times \frac{100}{3}$$

$$= \frac{350}{150} \times \frac{100}{3} = 66.66\%$$

5. Average profit = $\frac{\text{Sum of profits of the duration}}{\text{Total number of years}}$

$$\Rightarrow \frac{150 + 250 + 480 + 500}{4} = \frac{1380}{4} = 345.$$

Capacity Utilisation

$$\text{Capacity utilisation} = \frac{\text{Total Production}}{\text{Total Capacity}} \times 100$$

Ex.1 The total capacity of Tata Nano car plant in Gujrat is 150 car per day. In the month of April 2009 the plant manufactured at the rate of 120 car a day. Due to sharp increase in demand in May 2009, Tata company decided to increase the production to 200 car a day. Find the capacity utilisation in the month of April and May 2009.

Sol.: Capacity utilisation in April 2009

$$= \frac{120}{150} \times 100 = 80\%$$

Capacity utilisation in May 2009

$$= \frac{200}{150} \times 100 = 133\%$$

Ex.2 The manufacturing capacity of Nokia Inc. plant based in Yokohama Japan is 3,00,000 cellphones per day. In the month of March 2009 there was slump in demand due to recession and capacity utilisation come down to 30%. Find the production of cellphones in March 2009.

Sol.: Capacity utilisation

$$= \frac{\text{Total Production}}{\text{Total Capacity}} \times 100$$

Total production in march 2009 =

$$\frac{\text{Capacity Utilisation} \times \text{Total Capacity}}{100}$$

$$\Rightarrow \frac{30 \times 3,00,000}{100}$$

$$\Rightarrow 90,000 \text{ Ans.}$$

□□□□



Practice Exercise: I

Direction (Qs. 1 to 5) : Refer to the graph (Fig.) and answer the questions given below that

(Consumer price index in 1993-1994)

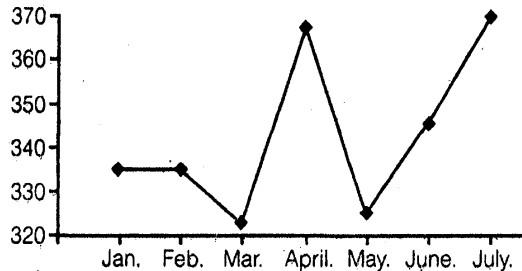

- Which month showed the highest absolute difference in the Consumer Price Index (CPI) over the previous month?
(a) March (b) April
(c) May (d) July
- Which month showed the highest percentage difference in the CPI over the previous month?
(a) March (b) April
(c) May (d) July
- For how many month was the CPI greater than 350?
(a) One (b) Two
(c) Three (d) Four
- In how many months was there a decrease in the CPI?
(a) One (b) Two
(c) Three (d) Four
- The difference in the number of months in which there was an increase in the CPI and the number of months in which there was a decrease was:
(a) One (b) Two
(c) Three (d) Four

Direction (Qs. 6 to 11) : Study the following graph to answer the given questions:

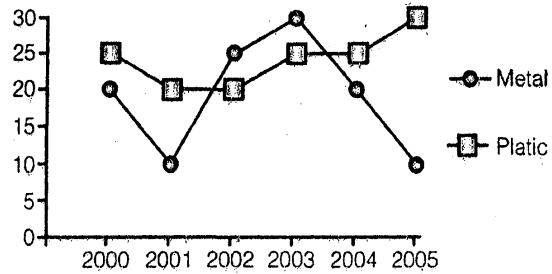

Consumption of Metals versus plastics in the given Years for Car manufacturing (in thousands tonnes)

The graph shows the trend of consumption of metals and plastic in the production of cars between 2000-05.

- The number of years for which the consumption of Metals was less than the consumption of Plastic over the given time period was:
(a) One (b) Two
(c) Three (d) Four
- The total consumption of plastic (for car manufacturing) divided by the total consumption of Metal (for car manufacturing) over the period will give a ratio closest to:
(a) 4 : 3 (b) 5 : 4
(c) 6 : 5 (d) 7 : 4
- Which item and for which year shows the highest percentage change in consumption over the previous year?
(a) Metal 2003 (b) Plastic 2003
(c) Metal 2002 (d) Plastic 2005
- For the two data series shown, how many years have shown in decrease in consumption (for both the items individually)?
(a) One (b) Two
(c) Three (d) Four
- Which year showed the highest percentage increase in the total consumption of the two?
(a) 2001 (b) 2002
(c) 2003 (d) 2004

11. Which year showed the highest percentage decrease in the total consumption of the two?
- (a) 2001 (b) 2002
(c) 2004 (d) 2005

Direction (Qs. 12 to 16): Study the following graph to answer the given questions:

Percent profit earned by two companies over the given years:

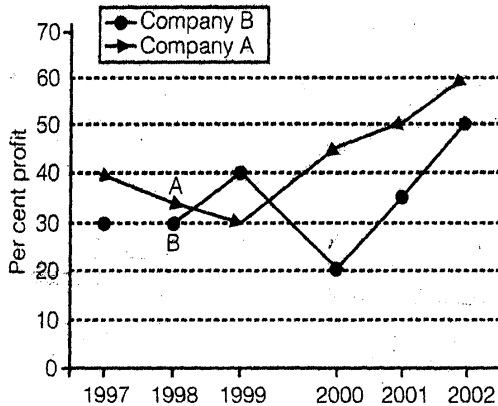

12. If the expenditure of Company B in 2000 was Rs. 200 crore, what was its income?
- (a) Rs. 240 crore
(b) Rs. 220 crore
(c) Rs. 160 crore
(d) Cannot be determined
(e) None of these
13. If the income of Company A in 2002 was Rs. 600 crore, what was its expenditure?
- (a) Rs. 360 crore
(b) Rs. 480 crore
(c) Rs. 375 crore
(d) Cannot be determined
(e) None of these
14. If the income of Company B in 1998 was Rs. 200 crores, what was its profit in 1999?
- (a) Rs. 21.5 crore
(b) Rs. 153 crore
(c) Rs. 46.15 crore
(d) Cannot be determined
(e) None of these

15. If the income of the two companies in 1998 were equal, what was the ratio of their expenditures?
- (a) 1 : 2
(b) 26 : 27
(c) 100 : 67
(d) Cannot be determined
(e) None of these

16. What is the percent increase in profit for company B from year 2000 to 2001?
- (a) 75 (b) 175
(c) 42.86
(d) Cannot be determined
(e) None of these

Direction (Qs. 17 to 21): Study the following graph carefully and answer the questions given below it.

Imports of 3 companies over the years (Rs. in crore)

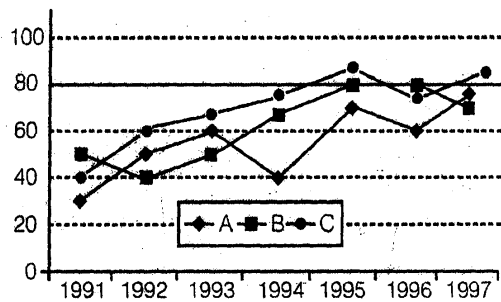

17. In which of the following years, the imports made by Company A was exactly equal to average imports
- (a) 1992 (b) 1993
(c) 1994 (d) 1995
(e) None of these
18. In which of the following years was the difference between the imports made by Company B and C the maximum?
- (a) 1995 (b) 1994
(c) 1991 (d) 1992
(e) None of these

19. In which of the following years was the imports made by Company A exactly half of the total imports made by Company B and C together in that year?

- (a) 1992 only (b) 1993 only
 (c) 1992 and 1993 (d) 1995 only
 (e) None of these

20. What was the percentage increase in imports by Company B from 1992 to 1993?

- (a) 10 (b) 25
 (c) 40 (d) 20
 (e) None of these

21. In which of the following years was the total imports made by all the three companies together the maximum?

- (a) 1996 only (b) 1997 only
 (c) 1995 only (d) 1995 & 1997 only
 (e) None of these

Solutions

Answer 1 to 5:

1. (b)
2. (b) Visually clear that it is April
3. (b) April and July – Two.
4. (b) The CPI decreased in March and May
5. (a) The CPI increased in three months (April, June and July) while it decreased in two months (March and May).
6. (d) Visually seen as 4.
7. (b) $145 : 115 = 29 : 23$ is closest to $5 : 4$
8. (c) Metals in 2002 is more than doubling over its 2001 value.
9. (a) 2001 is the only year which satisfy the condition
10. (b) 50% in 2002
11. (a) 33.33% between 200 to 2001.
12. (a) Income of Company B in 2000

$$= 200 \times \frac{120}{100} = \text{Rs. } 240 \text{ cr.}$$

13. (c) Expenditure of Company A in 2002

$$= 600 \times \frac{100}{160} = \text{Rs. } 375 \text{ cr.}$$

14. (d) We can find out the amount of profit in 1998, we do not know the income and expenditure of A and B therefore option (d) is the correct choice.

15. (b) Ratio of their expenditures

$$= \frac{100}{135} \times \frac{130}{100} = 26 : 27.$$

16. (d) Reqd. % increase = $\frac{35 - 20}{20} \times 100$
 = 75%.

17. (e) Average imports made by company A

$$= \frac{30 + 50 + 60 + 40 + 70 + 60 + 75}{7}$$

$$= \frac{385}{7} = 55$$

In none of the given years the imports is exactly equal to 55 (crore). Hence, the answer is (e)

18. (d) By visual inspection it is clear that 1992 is the desired year (as the distance between two points is the maximum in 1992).

19. (a) By mental observation

$$\left(\text{as } 50 = \frac{40 + 60}{2} \right), 1992$$

Only is the desired year. You do not need any calculation see the year where the point A lies exactly in the middle of points of B and C

20. (b) Reqd percentage increase = $\frac{50 - 40}{40}$
= 25%

21. (c) The total imports (in crore) made by all the three companies together : From the height of the points we observe that the total heights of three points is the maximum either in 1995 or 1997. If you observe carefully our clear answer is 1995, but to be sure we find actual values for the two years.

$$\text{In 1995} = 70 + 80 + 85 = 235$$

$$\text{In 1997} = 75 + 70 + 85 = 230$$

Clearly, 1995 is the desired year.

□□□□



Table



Practice Exercise: I

Direction (Qs. 1 to 5): Study the following Table carefully and answer the questions given below
Production of main crops in India (in million tonnes)

Crops	91-92	92-93	93-94	94-95	95-96	96-97
Pulses	20.5	22.4	24.6	23.5	27.8	28.2
Oilseeds	32.4	34.6	40.8	42.4	46.8	52.4
Rice	80.5	86.4	88.2	92.6	94.2	90.8
Sugarcane	140.8	150.2	152.2	160.3	156.4	172.5
Wheat	130.2	138.4	146.8	141.6	152.2	158.4
Coarse grain	45.6	52.8	60.4	62.2	58.2	62.8
Sum	450	484.8	513.2	522.8	535.6	565.1

- Production of sugarcane in 1993-94 was approximately what percentage of production of rice in 1992-93?
(a) 50 (b) 75
(c) 150 (d) 125
(e) 175
- Production of what type of crop was going to increase in each year in the given years?
(a) Rice (b) Pulse
(c) Sugarcane (d) Oilseeds
(e) None of these
- What was the average production of pulse in the given years?
(a) 26.8 million tonnes
(b) 20.5 million tonnes
(c) 24.5 million tonnes

- (d) 22.5 million tonnes
(e) None of these

- Production of oilseeds was what percentage of the total crops produced in the year 1991-92?
(a) 7.2 (b) 8.4
(c) 2.7 (d) 6.4
(e) None of these
- In which of the following years the total production of oilseeds in the years 1994-95, 1995-96 and 1996-97 was equal to the production of wheat?
(a) 1993-94 (b) 1994-95
(c) 1996-97 (d) 1992-93
(e) None of these

Direction (Qs. 6 to 10): The table given below shows production of five types of cars by a company in the years 1989 to 1994. Study the table and answer questions

Production of cars by a company

Year→ Type↓	1989	1990	1991	1992	1993	1994	Total
P	8	20	16	17	21	6	88
Q	16	10	14	12	12	14	78
R	21	17	16	15	13	8	90
S	4	6	10	16	20	31	87
T	25	18	19	30	14	27	133
Total	74	71	75	90	80	86	476

6. In which year the production of cars of all types taken together was approximately equal to the average of the total production during the period?
 (a) 1989 (b) 1991
 (c) 1993 (d) 1994
7. In which year the total production of cars of types P and Q together was equal to the total production of cars of types R and S together?
 (a) 1990 (b) 1991
 (c) 1994 (d) None of these
8. During the period 1989-94, in which type of cars was a continuous increase in production?
 (a) P (b) Q
 (c) R (d) S
9. The production of which type of cars was 25% of the total production of all types of cars during 1993?
 (a) S (b) R
 (c) Q (d) P
10. The per cent increase in total production of all types of cars in 1992 to total in 1991 was?
 (a) 15 (b) 20
 (c) 25 (d) 30
- (a) I (b) II
 (c) IV (d) None of these
12. For which company, has the amount of investment made increased continuously over the years?
 (a) I (b) II
 (c) III (d) None of these
13. For which company has the amount of investment made decreased continuously over the years?
 (a) V (b) IV
 (c) III (d) None of these
14. In which year, the amount of investment made was the least as compared to average investment made by all the companies over the years?
 (a) 1998 (b) 1999
 (c) 2000 (d) None of these
15. In which year, the percentage change in the total amount of investment made is the highest over its immediately preceding year?
 (a) 2002 (b) 2000
 (c) 2001 (d) None of these

Direction (Qs. 16 to 20): The following five questions are to be answered on the basis of the following table:

Weight Distribution in the Average Adult

Organs	Weight (in grams)
Muscles	30,000
Skeleton	10,000
Blood	5,000
Gastrointestinal Tract	2,000
Lungs	1,000
Liver	1,700
Brain	1,500

Direction (Qs. 11 to 15): These questions are based on the data given in the following table shown investment made by the five companies over the years (in lakh of rupees):

Company	Years				
	1998	1999	2000	2001	2002
I	20	21	50	35	75
II	29	31	23	46	42
III	31	29	27	22	16
IV	33	14	33	37	48
V	15	17	32	39	47
	128	112	165	179	228

11. Which company made more than 25 percent of the total investment made by all the companies in 2001?
 (a) 70,000 grams (b) More than 51 kg
 (c) 50,000 grams (d) Less than 50 kg
 (e) None of these
16. The total body weight of the average adult is

17. If the weight of the skeleton is represented as S, then the weight of the liver can be represented as
- (a) 1.7 S (b) 0.17 S
(c) 17 S (d) 71 S
(e) None of these

18. The ratio expressed in decimals of the weight of the blood to the weight of the gastrointestinal tract is
- (a) 0.4 (b) 4.0
(c) 2.5 (d) 0.25
(e) None of these

19. The ratio expressed in decimal for weight of the brain to the weight of the muscles is
- (a) 0.50 (b) 0.15
(c) 0.20 (d) .005

20. The ratio expressed in decimal of the weight of the brain to the weight of the lungs is
- (a) 1.5 (b) 0.15
(c) 15.0 (d) 5.1
(e) 15.0

Direction (Qs. 21 to 25): The figures for a country's Foreign Trade for the years 1990-91 to 1996-97 are given in the following table. Answer these questions on the basis of the information given:

A Country's Foreign Trade
(Rupees in Crores)

Year	Exports	Imports	Trade Deficit
1990-91	6711	12549	5838
1991-92	7806	13608	5802
1992-93	8803	14293	5490
1993-94	9771	15831	6060
1994-95	11855	17173	5318
1995-96	10420	18371	7951
1996-97	12550	20063	7513

21. Which of the following showed an increase every year?
- (a) Exports (b) Imports
(c) Trade deficit (d) All of these

22. The ratio of imports to exports was maximum in the year
- (a) 1990-91 (b) 1996-97
(c) 1995-96 (d) 1992-93

23. The percentage increase in exports was maximum in the year
- (a) 1990-91 (b) 1996-97
(c) 1994-95 (d) 1993-94

24. The total trade deficit for the last five years?
- (a) Rs 28,508 crore (b) Rs. 32,332 crore
(c) Rs. 44,322 crore (d) Rs. 33,232 crore

25. The difference between imports and exports was maximum in the year
- (a) 1995-96 (b) 1996-97
(c) 1994-95 (d) 1993-94

Direction (Qs. 26 to 30): Study the following data apropos Indian population movements to answer these questions :

Year	Population in millions	Percentage Decadal Increase
1901	240	-
1911	260	8.33
1921	252	-3.1
1931	290	15.1
1941	330	13.8
1951	390	18.2
1961	460	17.95
1971	570	23.9
1981	700	22.8
1991	870	24.3

26. The maximum and minimum percentages of decadal increase are
- (a) 24.3 and 8.33 (b) 23.9 and -3.1
(c) 22.8 and 15.1 (d) 18.2 and 13.8
(e) None of these

27. The percentage decadal increase is almost the same between the years
 (a) 1931-41; 1941-51
 (b) 1941-51; 1951-61
 (c) 1951-61; 1961-71
 (d) 1961-71; 1971-81
 (e) None of these
28. The percentage increase of population in 1971 with population of 1941 as the base year is nearly
 (a) 52 (b) 63
 (c) 65 (d) 73
 (e) 81
29. The ratio of increase in population between 1901 and 1941 to the increase in population between 1951 and 1991 is nearly
 (a) 3/10 (b) 4/17
 (c) 3/16 (d) 5/21
 (e) 1
30. The percentage increase in population over the entire period is nearly times the percentage decadal increase between 1961 and 1971
 (a) 9 (b) 11
 (c) 10 (d) 12
 (e) 7

Solutions

Answer 1 to 5:

1. (e) Required per cent = $\frac{152.2}{86.4} \times 100 \approx 175\%$.
2. (d)
3. (c) Average production of pulse

$$= \frac{20.5 + 22.4 + 24.6 + 23.5 + 27.8 + 28.2}{6}$$

$$= \frac{147.0}{6} = 24.5 \text{ million tonne.}$$

4. (a) Required percentage = $\frac{32.4}{450} \times 100 = 7.2\%$
5. (b) Total production of oilseeds in the given years
 $= 42.4 + 46.8 + 52.4 = 141.6$
 Which is equal to the production of wheat in 1994-95.
6. (c)
7. (d) Answer will be 1993
8. (d)
9. (a) $25\% \text{ of } 80 = 20 = \text{production of S's car in } 1993$
10. (b) Required per cent increase
 $= \frac{90 - 75}{75} \times 100 = 20\%$
11. (b) $\frac{53}{112} \times 100 = 25.70\%$
12. (d) For company V
13. (c) For company III
14. (b)
15. (b) Percentage change in the total amount of investment made in 2000 over 1999.
 $= \frac{53}{112} \times 100 = 47.32\%$
16. (b) 51200 gm = 51 kg 200 gm
17. (b) S = 10000
 $\therefore \text{Weight of Liver} = 1700$
 $= \frac{S}{10000} \times 1700 = 0.17 S.$
18. (c) $\frac{5}{2} = 2.5$
19. (d) $\frac{1500}{30000} = \frac{1}{20} = .05$
20. (a) $\frac{1500}{1000} = \frac{3}{2} = 1.5.$
21. (b)

22. (a) The ratio of imports to exports in the year

$$1990-91 = \frac{12549}{6711} = 1.87$$

$$1996-97 = \frac{20063}{12550} = 1.60$$

$$1995-96 = \frac{18311}{10420} = 1.76$$

$$1992-93 = \frac{14293}{8803} = 1.62$$

23. (c) Percentage increase in exports in

$$1996-97 = \frac{12520 - 10420}{10420}$$

$$\times 100 = 20.15\%$$

$$1994-95 = \frac{11855 - 9771}{9771} \times 100 = 21.33\%$$

$$1993-94 = \frac{9771 - 8803}{8803} \times 100 = 11\%$$

24. (b) $5490 + 6060 + 5318 + 7951 + 7513$
 $= \text{Rs. } 32332 \text{ crore.}$

25. (a) The difference between the imports in

$$1995-96 = \text{Rs } 7951 \text{ crore}$$

$$1996-97 = \text{Rs } 7513 \text{ crore}$$

$$1997-98 = \text{Rs } 5318 \text{ crore}$$

$$1993-97 = \text{Rs } 6060 \text{ crore}$$

26. (e) 24.3 and -3.1

27. (b) 18.2 and 17.95

28. (d) $\frac{570 - 330}{330} \times 100 = \frac{240}{330} \times 100$
 $= 72.73\% \approx 73\%$

29. (c) $\frac{330 - 240}{870 - 390} = \frac{90}{480} = \frac{3}{16}$

30. (b) Let $(870 - 240) \times 100 = K \times 23.9$

$$\Rightarrow K = \frac{630}{240} \times \frac{100}{23.9} = 10.98 \approx 11.$$

□□□□

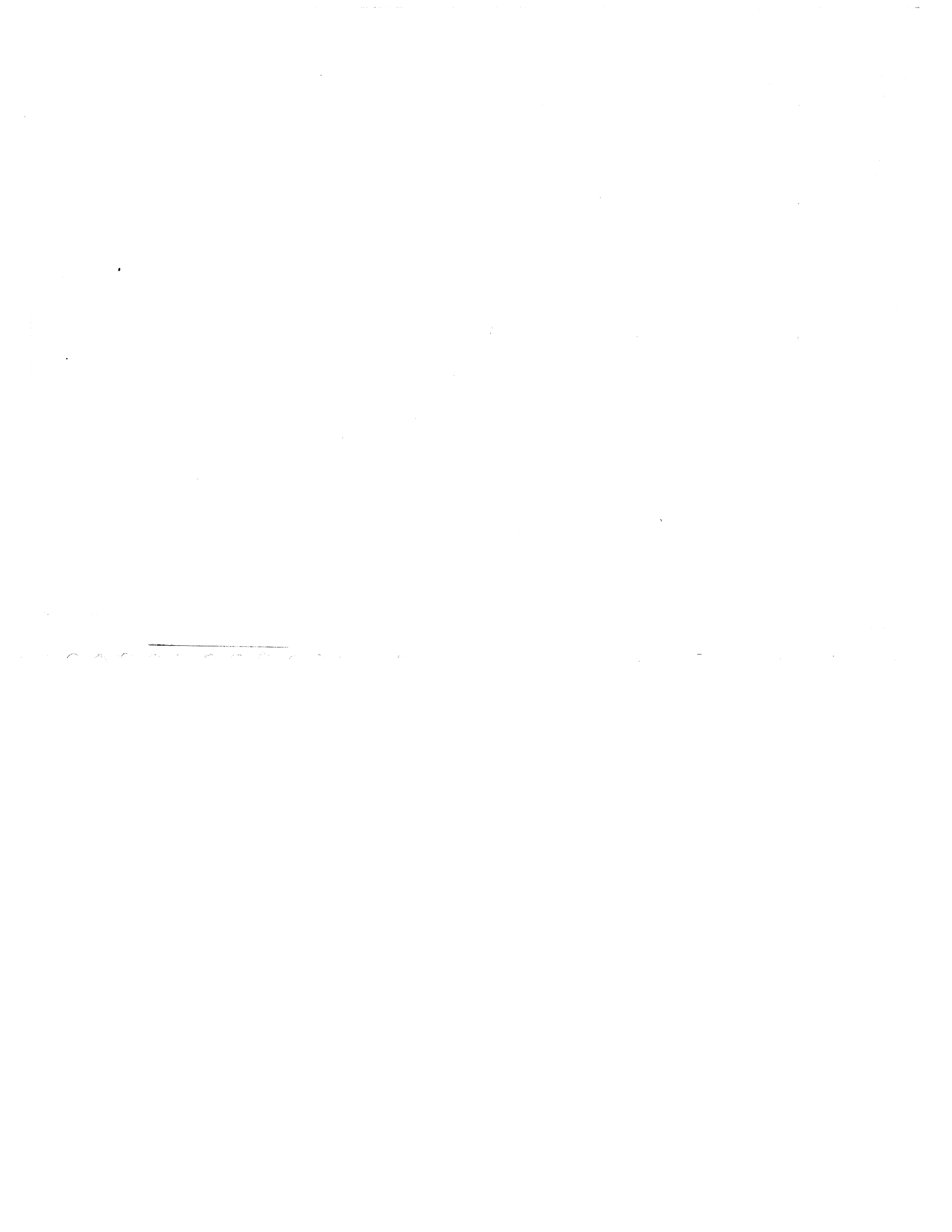



Bar Diagram

Bar Diagrams

There are mainly six types of Bar Diagrams.

- Simple Bar Diagram
- Multiple Bar Diagram
- Compound Bar Diagram
- Percent Bar Diagram
- Horizontal Bar Diagram
- Floating Bar Diagram etc.

Simple Bar Diagram

Simple Bar Diagram is similar to graph. Only one set of data can be represented in simple Bar Diagram. It is different to graph only in an aspect that in place of points there are bars which represent values of respective years.

Ex.1

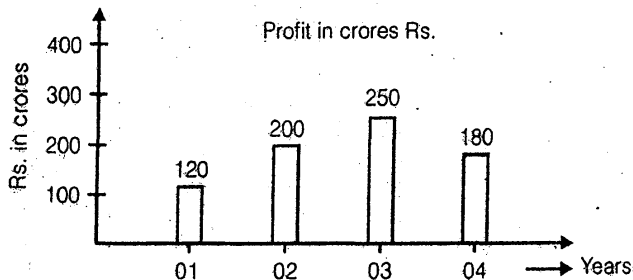

Fig. (1) Balance Sheet of MTS incorporation

Sol.: From the Bar Diagram given in Fig. (1) We can determine following things

1. Percent increment in profits

$$2001 - 02 \Rightarrow \frac{80}{120} \times 100 = 66.66\%$$

$$2002 - 03 \Rightarrow \frac{50}{200} \times 100 = 25\%$$

$$2003 - 04 \Rightarrow \frac{-70}{250} \times 100 = -28\%$$

- Maximum increase in profit was observed in financial year 2001-02.
- Minimum increase in profit was observed in financial year 2003-04.

2. Average profit = $\frac{120 + 200 + 250 + 180}{4}$

$$= \frac{750}{4} = 187.5 \text{ crore}$$

3. Annual average growth rate

$$= \frac{180 - 120}{120} \times \frac{100}{3}$$

$$= \frac{60}{120} \times \frac{100}{3} = 16.66\%$$

Multiple Bar Diagram

In Simple Bar Diagrams only one set of data can be represented. To represent multiple set of data for different years we use multiple bar diagrams.

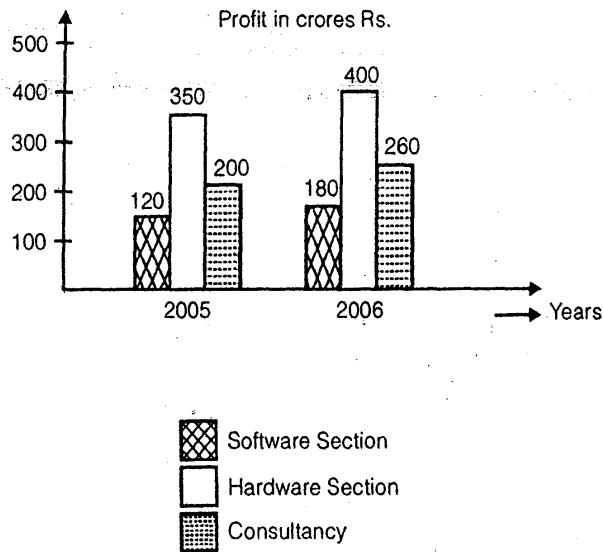

Fig. (2) Balance Sheet of Megha-soft for two financial years 2005 and 2006.

From the multiple bar diagram shown in Fig. (2) we can calculate following things

- Sectional Growth
 - Software section $180 - 150 = 30$ Cr.
 - Hardware section $400 - 350 = 30$ Cr.
 - Consultancy $260 - 200 = 60$ Cr.
 - Highest absolute increase in profit is observed by consultancy section.
 - Minimum absolute increase in profit is observed by software section
- Growth rates in percent terms.

$$\text{Software section} \Rightarrow \frac{180 - 150}{150} \times 100 = 20\%$$

$$\text{Hardware section} \Rightarrow \frac{400 - 350}{350} \times 100 = 14.28\%$$

$$\begin{aligned} \text{Consultancy} &\Rightarrow \frac{260 - 200}{200} \times 100 \\ &= 30\% \end{aligned}$$

- Minimum growth is observed by Hardware section
 - Maximum growth is observed by consultancy section.
- Growth rate of megha soft for the duration 2005-06.

$$\begin{aligned} &\frac{\text{Profit in 2006} - \text{Profit in 2005}}{\text{Profit in 2005}} \times 100 \\ &\Rightarrow \frac{(180 + 400 + 260) - (150 + 350 + 200)}{(150 + 350 + 200)} \times 100 \\ &\Rightarrow \frac{840 - 700}{700} \times 100 \\ &= \frac{140 \times 100}{700} = 20\% \end{aligned}$$

Compound Bar Diagram

Compound Bar Diagrams are similar to Multiple Bar Diagrams. The only difference between these two Bar Diagrams is that in Compound Bar Diagram a single Bar Diagram is subdivided into different parts, while multiple bars are used in Multiple Bar Diagrams. Compound Bar Diagrams are also known as compound sub-divided Bar Diagrams.

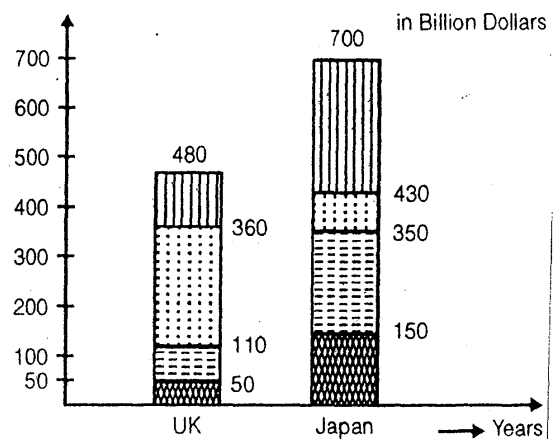

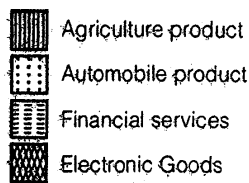

**Fig. Export Basket of two countries
UK and Japan for year 2005 in \$ billion**

From the Compound Bar Diagram we answer following set of questions.

Ex. 1. Export of Agriculture product of UK is how much percent of export of Automobile product of Japan?

Sol. Export of Agriculture product of UK
= \$ 50 billion
Export of Automobile product of Japan
= \$ 200 billion
$$= \frac{50}{200} \times 100 = 25\%$$

Ex. 2. Export of Automobile product of Japan is how many times than that of UK.

Sol. Automobile Export of Japan
= \$ 200 billion
Automobile Export of UK = \$60 billion
$$= \frac{260}{60} = \frac{10}{3} \text{ Ans.}$$

Ex. 3. Total export given in Fig. of Japan is how much percentage higher than that of UK?

Sol.
$$= \frac{640 - 480}{480} \times 100$$

$$= \frac{160}{480} \times 100 = 33.33\%$$

Percent Bar Diagram

Percent Bar Diagram is similar to Compound Bar Diagram. The only difference is that the height of bars are equal and represent hundred percent in percent bar diagram, whereas heights of different bars in compound bar diagram may or may not be equal.

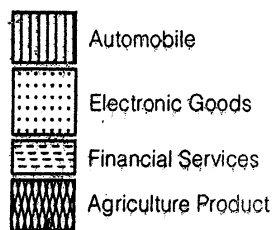
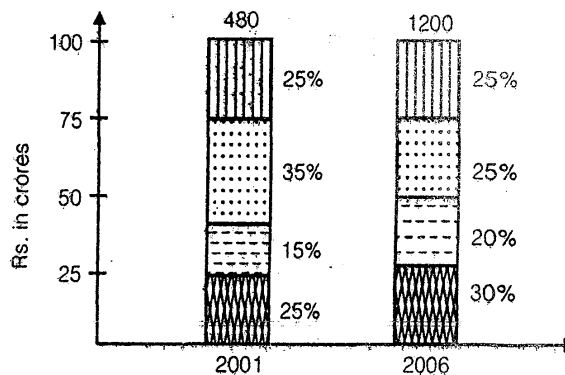

**Fig. Export Basket of XYZ for financial
year 2001 and 2006 in billion dollars.**

From the above figure we can calculate following things.

(1) Percent increment in export for the given duration 2001-06

$$\frac{1200 - 480}{480} \times 100 = 150\%$$

(2) Export of Japan for financial year 2001 consist of

- \$ 120 billion for Automobiles
- \$ 72 billion for Electronic Goods
- \$ 158 billion for financial services
- \$ 120 billion for Agriculture product

(3) Export Basket of Japan for financial year 2006 consists of

- \$ 360 billions for automobiles
- \$ 240 billions for electronic goods

- \$ 300 billion for financial services
 - \$ 300 billion for agriculture product
- (4) Export of financial services in year 2002 is how many times more than export of electronic goods in 2001?

Sol. Export of financial services in 2002 = 300
Export of electronic goods in 2001 = 72

$$\frac{300 - 72}{72} = 3.16 \text{ times approx.}$$

Horizontal Bar Diagrams

Horizontal Bars are similar to simple bar diagrams. The only difference is that in case of horizontal bar, representation is horizontal, whereas vertical bars are used for simple bar diagram. Horizontal bar diagram is used in cases when we require to represent data sets for comparatively large number of years. All the calculation and observation of both the Bar Diagrams are similar.

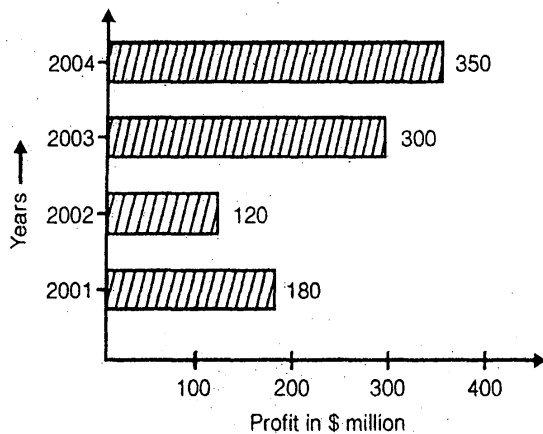

Fig. (5) Profits of Tamasha.com for four consecutive financial year.

□□□□



Practice Exercise: I

Direction (Qs. 1 to 5): Study the following graph carefully and answer the questions given below:

Production of foodgrains by a State over the years (1000 tons)

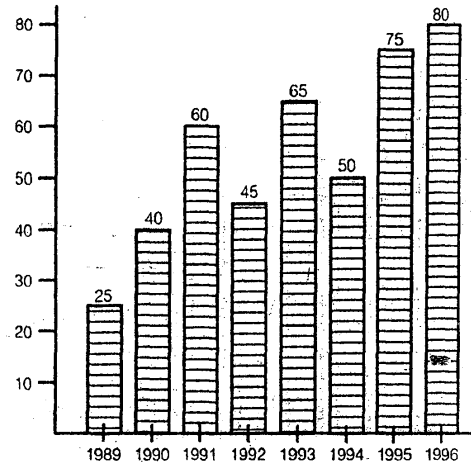

- The average production of 1990 and 1991 was exactly equal to the average production of which of the following pairs of years?
 - 1991 and 1992
 - 1992 and 1994
 - 1993 and 1994
 - 1994 and 1995
 - None of these
- What was the difference in the production of foodgrains between 1991 and 1994?
 - 10000 tons
 - 15000 tons
 - 500 tons
 - 5000 tons
 - None of these
- In which of the following years was the percentage increase in production from the previous year the maximum among the given years?
 - 1991
 - 1993
 - 1995
 - 1990
 - None of these

4. In how many of the given years was the production of foodgrains more than average production of the given years?
 (a) 2 (b) 3
 (c) 4 (d) 1
 (e) None of these
5. What was the percentage drop in the production of foodgrains from 1991 to 1992?
 (a) 15 (b) 20
 (c) 25 (d) 30
 (e) None of these

Direction (Qs. 6 to 10): Study the following graph carefully and answer the questions given below :

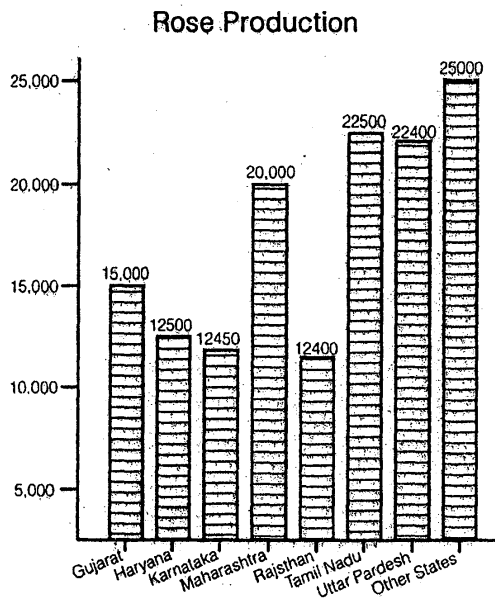

6. Which of the following State(s) contribute(s) less than 10 % in the total rose production?
 (a) Only Rajasthan
 (b) Rajasthan, Karnataka
 (c) Rajasthan, Karnataka, Haryana
 (d) Rajasthan, Karnataka, Haryana and Gujarat
 (e) None of these
7. By what percentage rose production of other States is more than that of the Maharashtra?
 (a) 25 (b) 30
 (c) 20 (d) 15
 (e) None of these

8. What is the approximate average production of roses (in thousands) across all the states?
 (a) 21 (b) 20
 (c) 19 (d) 18
 (e) 17
9. Approximately what percentage of the total rose production is shared by the other States?
 (a) 10 (b) 20
 (c) 30 (d) 40
 (e) 35
10. If total percentage contribution of the States having production of roses below twenty thousand is considered, which of the following statements is true?
 (a) It is little above 40%
 (b) It is exactly 35%
 (c) It is below 35%
 (d) It is little below 30%
 (e) None of these

Direction (Qs. 11 to 15): Study the following graph carefully and answer the questions given below it:

Import and Export of spare parts by an automobile company over the given years

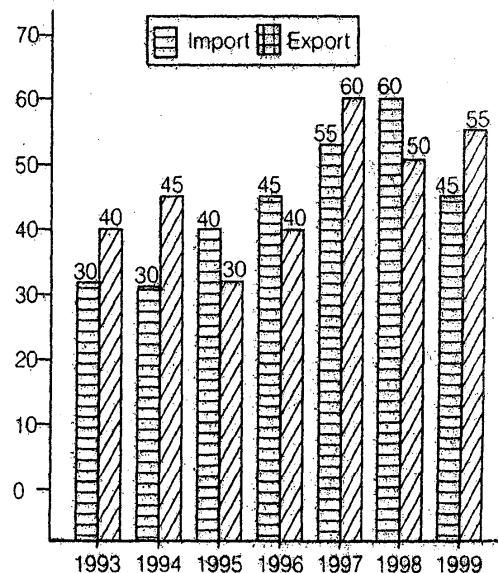

11. During which year the percentage rise/fall in imports from the previous year is the lowest?

- (a) 1994 (b) 1998
(c) 1997 (d) 1995
(e) None of these

12. What is the ratio of total imports to total exports for all the given years together?

- (a) 31:35 (b) 35:31
(c) 65:63 (d) 63:65
(e) None of these

13. In which of the following pairs of years the total import is equal to total export in the same pair of years?

- (a) 1996-1997 (b) 1993-1998
(c) 1998-1999 (d) 1995-1996
(e) None of these

14. The total exports in the year 1995, 1996 and 1999 together are what per cent of the total import during the same period? (Up to two decimal places)

- (a) 107.41 (b) 107.14
(c) 93.33 (d) 93.67
(e) None of these

15. Which of the following pairs of years and the per cent increase in the export over the previous year is correctly matched?

- (a) 1996-14.29 (b) 1997-40
(c) 1995-33.33 (d) 1994-11.11
(e) None of these

Direction (Qs. 16 to 20): These questions are based on the following bar graph. Read the graph and answer the questions.

Finances of XYZ Railway

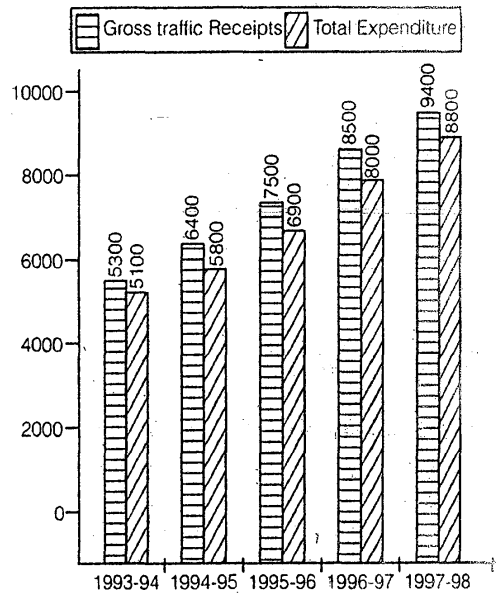

16. What is the percentage increase in the gross traffic receipts in 1995-96 as compared to 1993-94?

- (a) 33.9% (b) 41.5%
(c) 20.7% (d) 17%

17. If profit = gross traffic receipts - total expenditure then in 1996-97, what percentage of gross traffic receipts is the profit made?

- (a) 5.9% (b) 6.4%
(c) 7.2% (d) 8%

18. In which year was the profit as a percentage of gross traffic receipts the highest?

- (a) 1997-98 (b) 1996-97
(c) 1995-96 (d) 1994-95

19. In order to make a profit of 10%, what should have been the gross traffic receipts (in Rs. crore) in 1994-95, total expenditure remaining the same?

- (a) 5667 (b) 5876
(c) 6444 (d) 7667

20. By what amount (in Rs. crore) has the expenditure increased over the period 1993-94 to 1997-98?
- (a) 4100 (b) 3900
(c) 3850 (d) 3700

Direction (Qs. 21 to 28): Study the following graph to answer these questions:

Tea in India (in million kg)

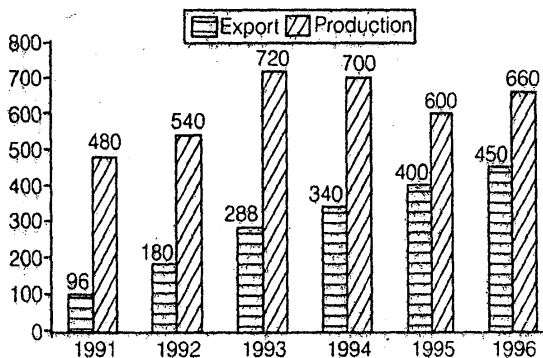

Per Capita Availability in gm

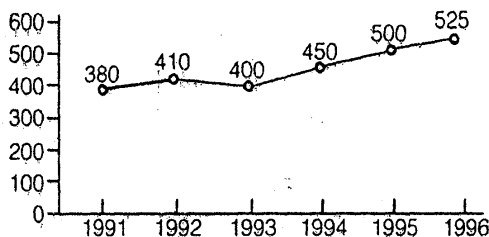

21. Which year shows the maximum percentage of export with respect to production?
- (a) 1992 (b) 1993
(c) 1996 (d) 1995
22. The population of India in 1993 was
- (a) 800 million (b) 1080 million
(c) 985 million (d) 900 million
23. If the area under tea production was less by 10% in 1994 than in 1993 then the approximate rate of increase in the productivity of tea in 1994 was
- (a) 97.22 (b) 3
(c) 35 (d) None of these

24. The average proportion of tea exported to the tea production, over the period is
- (a) 0.87 (b) 0.47
(c) 0.48 (d) 0.66

25. What is the first half decade's average per capita availability of tea?
- (a) 457 gms (b) 535 gms
(c) 446 gms (d) 430 gms

26. In which year was the per capita availability of tea minimum?
- (a) 1996 (b) 1994
(c) 1991 (d) None of these

27. In which year, there was minimum percentage of export with respect to production?
- (a) 1991 (b) 1992
(c) 1993 (d) 1994

28. In which year we had maximum quantity of tea for domestic consumption
- (a) 1994 (b) 1991
(c) 1993 (d) 1996

Direction (Qs. 29 to 36): Study the following to answer these questions

Slum Population in Metropolis : 1991

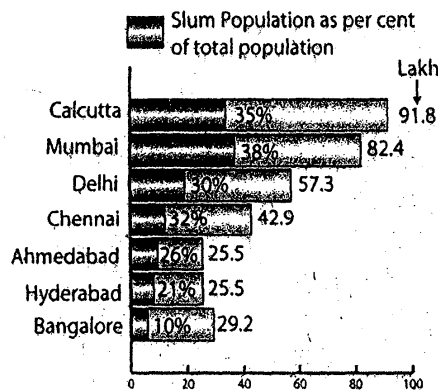

29. The total slum population of Calcutta in 1991 was approximately
- (a) 30 lakh (b) 31 lakh
(c) 32 lakh (d) 33 lakh

30. The difference in the slum population of Bangalore and Hyderabad was

- (a) 4.1 lakh (b) 3.71 lakh
(c) 2.43 lakh (d) 2 lakh

31. The city with the highest slum population was

- (a) Mumbai (b) Calcutta
(c) Delhi (d) Chennai

32. Two cities with nearly equal slum population were

- (a) Ahmedabad and Hyderabad
(b) Delhi and Chennai
(c) Hyderabad and Bangalore
(d) Mumbai and Calcutta

33. The slum population of Delhi was more than 3 times the slum population of

- (a) Hyderabad (b) Ahmedabad
(c) Bangalore (d) Chennai

34. The slum population of all the seven cities nearly equalled the total population of

- (a) Calcutta and Bangalore
(b) Delhi and Chennai
(c) Delhi and Hyderabad
(d) Mumbai and Ahmedabad

35. The ratio of slum population to total population in Calcutta is times the same ratio in Bangalore

- (a) 3 (b) 3.5
(c) 4 (d) 5

36. In terms of slum population, the second city with least population was

- (a) Delhi (b) Bangalore
(c) Ahmedabad (d) Hyderabad

□□□□

Solutions

Answer 1 to 5:

1. (e)

2. (a) Required difference
= 60 - 50 = 10,000 tonne.

3. (d) Percentage increase in production
= $\frac{15}{25} \times 100 = 60\%$

4. (c) Average production
= $\frac{25 + 40 + 60 + 45 + 65 + 50 + 75 + 80}{8}$
= $\frac{440}{8} = 55$.

5. (c) Required percentage drop
= $\frac{60 - 45}{60} \times 100 = 25\%$

6. (c) Total rose production
= (15 + 12.5 + 12.45 + 20 + 12.4 + 22.4 + 22.5 + 25) × 1000 = 142250
Percentage production of rose in the States (the lowest four states)
Rajashtan Karnataka Haryana Gujarat
8.71 8.75 8.78 10.54

7. (a) Required percentage

$$= \frac{25 - 20}{20} \times 100 = 25\% \text{ (more)}$$

8. (d) Total production of rose by all the states
= 142250

$$\therefore \text{Average} = \frac{142250}{8 \times 1000} = 18 \text{ thousand}$$

9. (b) Required percentage

$$= \frac{25}{142.25} \times 100 \approx 20\%$$

10. (e) It is 36.8% approximately.

11. (a)

$$\text{In 1995, } \frac{400}{600} \times 100 = 66.66\%$$

12. (e)

$$\text{In 1996, } \frac{450}{660} \times 100 = 68.18\%$$

13. (a), (b) (c), Obvious from the chart

14. (e) Total exports in the years 1995, 1996 and 1999 = 35 + 40 + 55 = 130 crore

Total imports in the years 1995, 1996 and 1999 = 40 + 50 + 55 = 135 crore

$$\text{Now required \%} = \frac{130 \times 100}{135} = -96.29\%$$

15. (e) If you calculate approximate value you reject (b), (c), and (d). Now check (a).

In 1996, % increase in export

$$= \frac{5}{35} \times 100 = \frac{100}{7} = 14.29\%$$

16. (b) $\frac{(7500 - 5300) = 2200 \times 100}{705300} = 41.5\%$

17. (a)

18. (d)

19. (c) Let GTRE be Rs. x

$$\therefore x - x \times 10\% = 5800$$

$$\therefore x = \frac{5800 \times 10}{9} = \text{Rs. } 6444.4$$

20. (d) 8800 - 5100 = 3700.

21. (c) In 1991, $\frac{96}{480} \times 100 = 20\%$

$$\text{In 1992, } \frac{180}{540} \times 100 = 33\frac{1}{3}\%$$

$$\text{In 1993 } \frac{288}{720} \times 100 = 40\%$$

$$\text{In 1994, } \frac{340}{700} \times 100 = 48.57\%$$

22. (b) 720 - 288 = 432 million = Total availability of tea in 1993

$$\text{Population of India} = \frac{432}{0.4} = 1080 \text{ million.}$$

23. (d)

24. (b)

25. (d) Average tea exported during 1991-1996 = 1754 million kg. Average tea produced during 1991-1996 = 3700 million kg

$$\therefore \text{Required ratio} = \frac{1754}{3700} = 0.47.$$

25. (d) Per capita availability of tea from 1991 to 1995

$$= 380 + 410 + 400 + 450 + 500 = 2140 \text{ gm}$$

\therefore Average per capita availability

$$= \frac{2140}{5} = 428 \approx 430 \text{ gm.}$$

26. (c)

27. (a)

28. (c)

In 1991, 480 - 96 = 384 million tonnes

In 1993, 720 - 288 = 432 million tonnes

In 1994, 700 - 340 = 360 million tonnes

In 1996, 660 - 450 = 210 million tonnes

29. (c) 35% of 91.9 = 32.165 \approx 32 lakh

30. (c) 21% of 25.5 - 10% of 29.2 = 5.355 - 2.920 = 2.435 lakh

31. (b) Slum Population in

Calcutta = 32.165 lakh

Mumbai = 31.3132 lakh

Delhi = 17.190 lakh
 Chennai = 13.728 lakh
 Ahmedabad = 6.630 lakh
 Hyderabad = 5.355 lakh
 Bangalore = 2.920 lakh

32. (d)
 33. (a)
 34. (d)

35. (b) Let $\frac{32.165}{91.9} = k \times \frac{2.92}{29.2} \Rightarrow k = 3.5$.

36. (d)



Practice Exercise: II

Direction (Qs. 1 to 5): Study the diagram carefully and answer the questions given below it

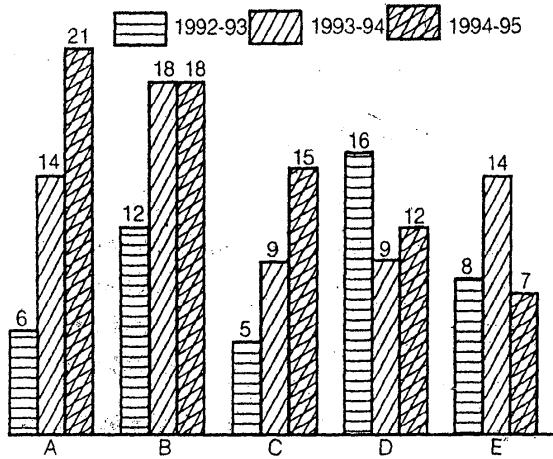

Cotton production of some states in ,000 tonnes

1. The production of state D in 1993-94 is how many times its production in 1994-95?
 (a) 1.33 (b) 0.75
 (c) 0.56 (d) 1.77

2. In which of the states there is a steady increase in the production of cotton during the given period?
 (a) A & B (b) A & C
 (c) B only (d) D & E
3. How many tonnes of cotton was produced by state E during the given period?
 (a) 2900 (b) 29000
 (c) 290000 (d) 29000000
4. How many states showing below average production in 1992-93 showed above average production in 1993-94?
 (a) 4 (b) 2
 (c) 3 (d) 1

5. Which of the following statements in false?
 (a) States A and E showed the same production in 1993-94
 (b) There was no improvement in the production of cotton in state B during 1994-95.
 (c) State A has produced maximum cotton during the given period
 (d) Production of States C and D together is equal to that of state B during 1993-94

Direction (Qs. 6 to 10): Study the diagram carefully and answer the question given below it

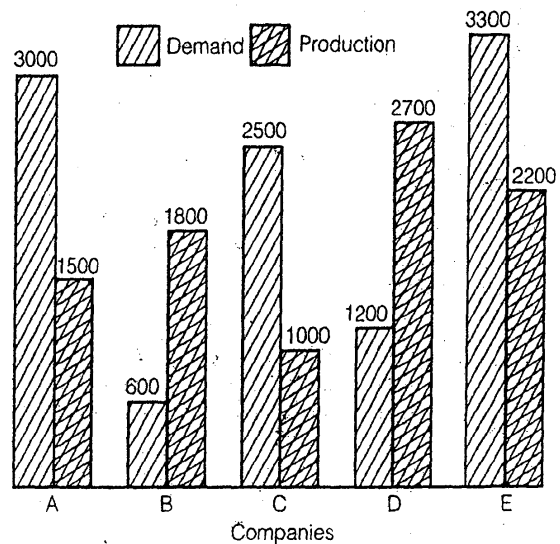

6. What is the ratio of companies having more demand than production to those having more production than demand?

- (a) 2 : 3 (b) 4 : 1
(c) 2 : 2 (d) 3 : 2

7. What is the difference between average demand and average production of the five companies taken together?

- (a) 1400 (b) 400
(c) 280 (d) 138

8. The production for company D is approximately how many times that of production of company A?

- (a) 1.8 (b) 1.5
(c) 2.5 (d) 1.11

9. The demand for company B is approximately what percent of the demand for company C?

- (a) 4 (b) 24
(c) 20 (d) 60

10. If company A desires to meet the demand by purchasing T.V. sets from a single company, which one of the following companies can meet the need adequately?

- (a) B (b) C
(c) D (d) None of these

Direction (Qs. 11 to 15): Study the following bar charts (Figs) before answering the questions

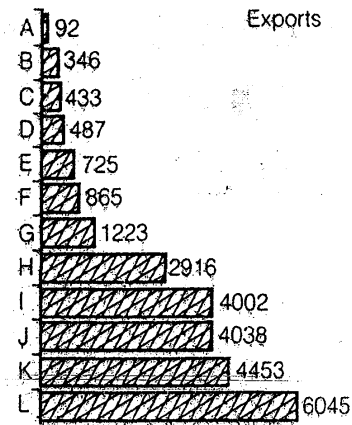
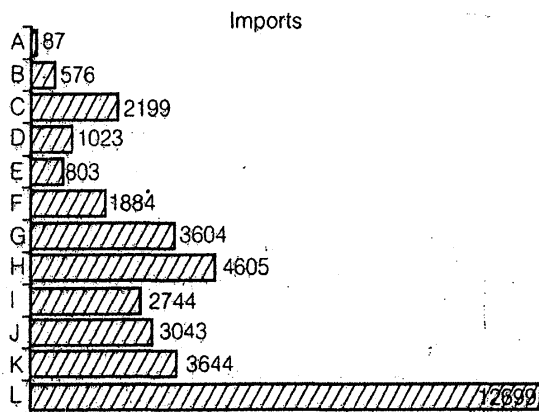

Fig. Foreign Trade by countries for year 1993-94

11. How many countries exhibited a trade surplus?

- (a) 5 (b) 4
(c) 3 (d) 6

12. The highest trade deficit was shown by which country?

- (a) C (b) G
(c) G (d) L

13. The ratio of Exports to Imports was highest for which country?

- (a) A (b) I
(c) J (d) K

14. The total trade/surplus for all the countries put together was?

- (a) 11286 surplus (b) 11286 deficit
(c) 10286 deficit (d) None of these

15. The ratio of the maximum exports to the minimum imports was closest to:

- (a) 64 (b) 69
(c) 74 (d) None of these

Direction (Qs. 16 to 20): Shows the compositions of the GDP of two countries (India and Pakistan)

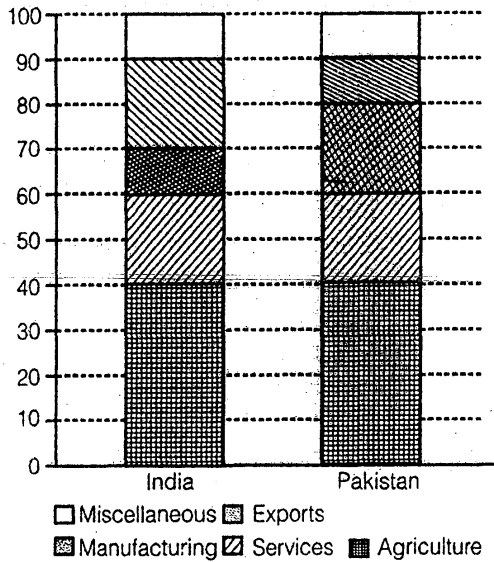

Solutions

Answer 1 to 5:

16. What fraction of India's GDP is accounted for by services?

- (a) $\frac{6}{33}$ (b) $\frac{1}{5^{\text{th}}}$
 (c) $\frac{2}{3^{\text{rd}}}$ (d) None of these

17. If the total GDP of Pakistan is Rs. 10,000 crore, then the GDP accounted for by Manufacturing is:

- (a) Rs 200 crore (b) Rs 600 crore
 (c) Rs 2,000 crore (d) Rs 6,000 crore

18. The total GDP of India is Rs 30,000 crores, then the GDP accounted for By Agriculture, Services and Miscellaneous is:

- (a) Rs. 18,500 crore (b) Rs 18,000 crore
 (c) Rs. 21,000 crore (d) Rs. 15,000 crore

19. Which country accounts for higher earning out of Services and Miscellaneous together?

- (a) India
 (b) Pakistan
 (c) Both spend equal amounts
 (d) Cannot be determined
 (e) None of these

20. If the total GDP is the same for both the countries then what percentage is Pakistan's income through agriculture more than India's income through services?

- (a) 100% (b) 200%
 (c) 133.33% (d) None of these

1. (b) Let production of D in 1993-94 = k × (production of D in 1994-95).

Then, 9 lakhs = $k \times 12$ lakhs

$$\text{or } k = \frac{9}{12} = \frac{3}{4} = 0.75.$$

2. (b) Clearly, there is a steady increase in the production of cotton during the given period in case of states A and C.

3. (b) $(8 + 14 + 7) \times 1000 = 29000$ tonnes

4. (b)

5. (c) During the given period, state B has produced 48000 tonnes while state A has produced only 41000 lakhs tonnes. Hence, statement (c) is false

6. (d) The companies having more demand than production are A, C, E. Their number is 3. The companies having more production than demand are B and D. Their number is 2.

7. (c) Average demand

$$= \left(\frac{3000 + 600 + 2500 + 1200 + 3300}{5} \right)$$

$$= 2120.$$

Average production

$$= \left(\frac{1500 + 1800 + 1000 + 2700 + 2200}{5} \right)$$

$$= 1840.$$

∴ Difference in having average demand & production = $(2120 - 1840) = 280$.

8. (a) Let production of D = $k \times$ production of A

$$\text{Then, } 2700 = k \times \frac{2700}{1500} = 1.8.$$

9. (b) Let $x\%$ of demand for C = Demand for B.

$$\text{Then, } \frac{x}{100} \times 2500 = 600$$

$$\text{or } x = \left(\frac{600 \times 100}{2500} \right) = 24\%$$

10. (c) Since D produces highest number of sets and A desire to meet the demand by purchasing surplus sets from a single company,
So, D can meet the demand of A.

11. (b) Out of a total of 12 countries, 8 showed a deficit while 4 showed a surplus.

12. (d) Visually it is clear that L has highest trade deficit.

13. (b) I has a ratio of $4002/2744 = 1.45$, which is the highest.

14. (b) Sum of exports - sum of imports = deficit (11286)

15. (b) 6045/87

16. (b) Service accounts for 20% , i.e., $1/5^{\text{th}}$ of the GDP of India

17. (c) 20% of 10000 = 2000

18. (c) $(40 + 20 + 10) \%$ of 30,000 = Rs, 21,0000 crore.

19. (d) Although the percentage on Service and Miscellaneous put together is equal for both the countries, we cannot comment on this since we have no data about the respective GDPs.

20. (a) Since the GDP is same, the answer will be got by $(40 - 20)/20 = 100\%$

□□□□

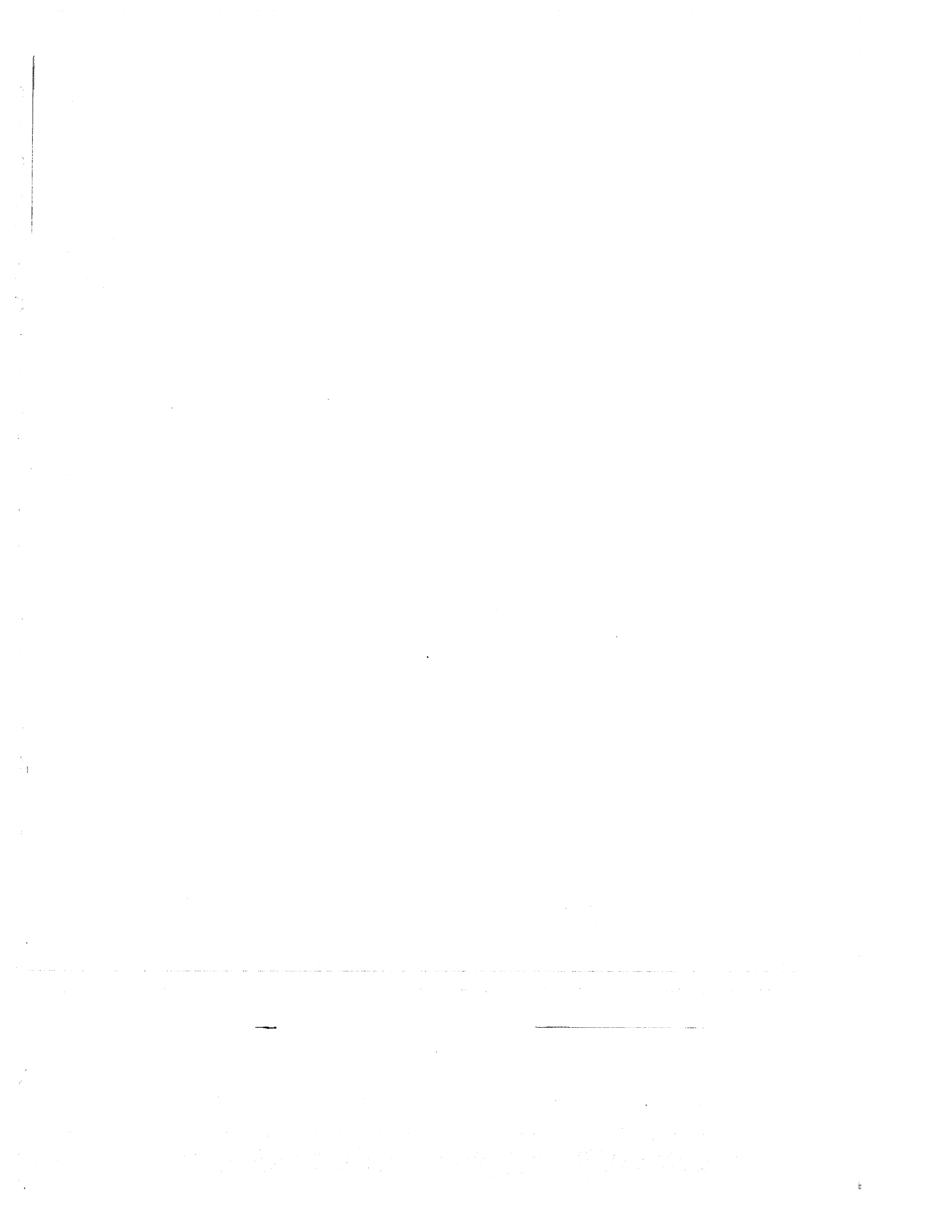



Pie-Chart

Pie-Charts are also known as circular charts. It represent datas in a very simple and lucid form such that interpretation become casier. Lets have a glimpse of Indian Economy through Pie-Charts.

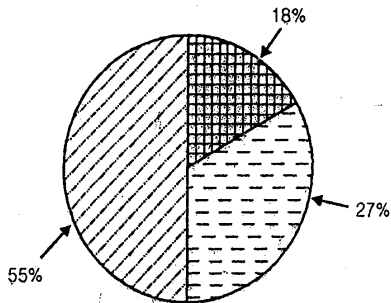

Pie-Chart:I

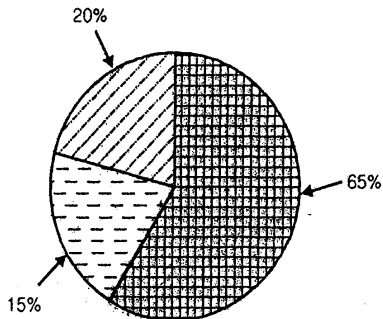

Sectoral Contribution to GDP in Indian Economy (Financial Year 2008-09)





Work force employed in difference sectors in Indian Economy (Financial Year 2008-09)

-  → Agriculture (Primary Sector)
-  → Industries (Secondary Sector)
-  → Services (Tertiary Sector)

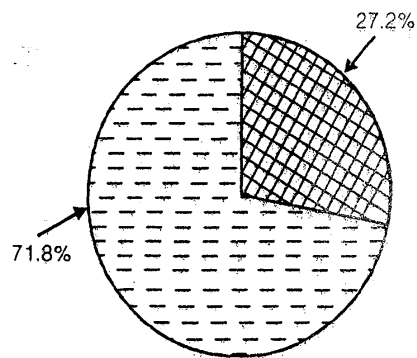
Pie-Chart:II





Demographic composition of Indian population living in Urban & Rural areas according to census 2001.

-  → Urban Areas
-  → Rural Area

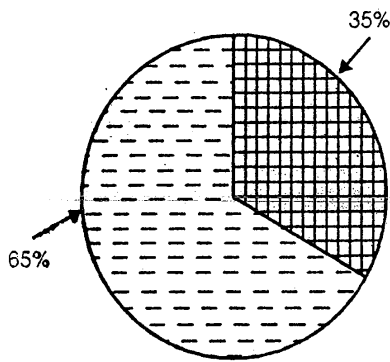
Pie-Chart:III





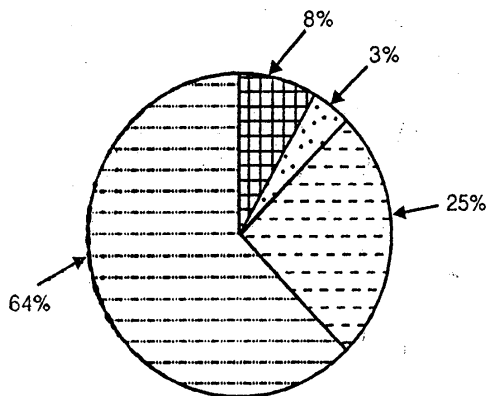

-  → illiterate Population
-  → literate Population

Literacy rates of Indian Population according to census 2001.

Pie-Chart:IV



-  → Thermal Energy
-  → Renewable Energy Resource
-  → Nuclear Energy
-  → Hydro Electric Power

Source of Power in India (Installed Capacity)

Pie Chart-I

Shows that Indian Economy is basically an agrarian Economy. Though the share of services [Tertiary Sector] is 55% yet number of people employed in this sector is merely 20%. Share of agriculture is merely 18% yet approximately two third of population is still dependent on agriculture to support their livelihood.

Contribution of industries is 27% and approximately 15% people are employed in industries.

Pie Chart-II

It shows that more than 2/3 of our population are living in rural areas. Urban population is still less than 1/3. It need urgent attention to provide facilities of urban amenities in rural areas. Rural development should be given top most priorities. Urban areas should be made more accessible for rural people, so that they can earn better, & enjoy healthy life.

Pie Chart-III

Literacy rate is shown in pie chart III. It reveals that even after getting 60 years of independence more than one-third of population do not know how to read and write, forget about their awareness. We need to devolve more resources & constitutional power to local bodies and state government so that they can increase their efforts to improve literacy rates. Since more than two-third population are living in rural areas, education in rural areas need complete overhaul. More financial resources, training of teachers, skill formation and capacity building should be given urgent attention.

Pie Chart-IV

It shows composition of different resources for power generation. We are still dependent much on Thermal Power to fulfil over energy demands. Nuclear energy and renewable resources of energy contributes merely 3% and 8% respectively. The Indo-US nuclear agreement (123

agreement) and nuclear agreements with other countries like France, Russia and Japan etc. can definitely improve the condition. We will be able to generate more nuclear energy in near future. Renewable energy resources like solar energy, wind energy, Geo-thermal energy can definitely contribute more towards our energy security. These are non-exhaustible resources of energy and can fulfil our energy needs for thousands of years.

Pie-Chart

There are two type of Pie Charts

1. Pie-Charts represented in Angular form
2. Pie-Charts represented in percent form

Conversion

$$\therefore 100\% = 360^\circ$$

$$\therefore 1\% = \frac{360}{100} = 3.6^\circ$$

Similarly

$$\therefore 360^\circ = 100\%$$

$$\therefore 1^\circ = \frac{100}{360} = \left(\frac{10}{36}\right)\%$$

Let us have an example on Angular form.

Example-I

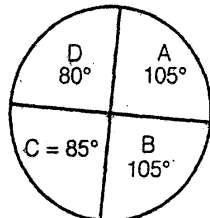

Fig. 5

Sectionwise composition of 720 students in a class in MADE EASY

From fig. 5 we can answer following questions.

1. Students in section A is how many percent more than that in section B?

Sol. Section A = 105°
Section B = 90°

$$\Rightarrow \frac{105 - 90}{90} \times 100$$

$$\Rightarrow \frac{15}{90} \times 100$$

$$\Rightarrow 16.66\% \text{ Ans.}$$

2. Students in section A is how many times than that of students in section D?

Sol. Students in A = 105°

Students in D = 80°

$$\frac{105}{80} = \frac{21}{16} = 1.3125 \text{ Ans.}$$

3. Difference between students in section C and Section D is how many times the difference between students in Section A and B.

Sol. Difference between C & D $\Rightarrow 85^\circ - 80^\circ = 5^\circ$
Difference between A & B

$$\Rightarrow 105^\circ - 90^\circ = 15^\circ$$

$$\Rightarrow \frac{[C-D]}{[A-B]} = \frac{5}{15} = \frac{1}{3} \text{ times Ans.}$$

4. Number of students in All the section
 $360^\circ = 720$ students

$$1^\circ = \frac{720}{360} = 2 \text{ students}$$

Section A = $105^\circ = 210$ students

Section B = $90^\circ = 180$ students

Section C = $85^\circ = 170$ students

Section D = $80^\circ = 160$ students

5. Percent composition of students
 $360^\circ = 100\%$

$$1^\circ = \frac{100}{360}\%$$

$$\text{Section A} = 105^\circ = \frac{105 \times 100}{360}\% = 29.167\%$$

$$\text{Section B} = 90^\circ = \frac{90 \times 100}{360} = 25\%$$

$$\text{Section C} = 85^\circ = \frac{85 \times 100}{360} = 23.611\%$$

$$\text{Section D} = 80^\circ = \frac{80 \times 100}{360} = 22.22\%$$

Example-2

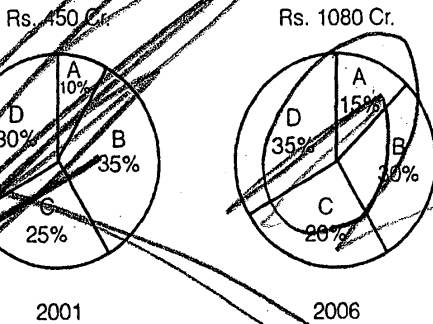

Pie-Chart in above figures represent sectional composition of a firm "V.G. com" in financial years 2001 and 2006.

We can have following observation

- Sectional composition of the firm in 2001 is
 Section A = 10% = 45 Cr.
 Section B = 35% = 157.5 Cr.
 Section C = 25% = 112.5 Cr.
 Section D = 30% = 135 Cr.
- Sectional Composition of the firm in financial year 2006 is
 Section A = 15% = 162
 Section B = 30% = 324
 Section C = 20% = 216
 Section D = 35% = 378
- Growth Rate
 Section A :
 45 to 162

$$\Rightarrow \frac{162 - 45}{45} \times 100 = 260\%$$

Section B :
157.5 to 324

$$\Rightarrow \frac{324 - 157.5}{157.5} \times 100 = 92\%$$

Section C :
112.5 to 216

$$\Rightarrow \frac{216 - 112.5}{112.5} \times 100 = 105.7\%$$

Section D : 135 to 378

$$\Rightarrow \frac{378 - 135}{135} \times 100 = 180\%$$

- Highest growth rate for the given duration 2001-2006 is observed by section A.
 - Minimum growth rate for the given duration 2001-2006 is observed by section C.
4. Growth rate for the duration 2001-2006 is

$$\frac{1080 - 450}{405} \times 100 = 140\%$$

5. Average Annual Growth rate for duration 2001-2006 is

$$\frac{1080 - 450}{405} \times \frac{100}{5} = 28\%$$

□□□□



Practice Exercise: I

Direction (Qs. 1 to 7): These questions are to be answered on the basis of the following pie chart which gives marks scored by a student in different subjects- English, Hindi, Mathematics, Science and Social Science in an examination. Assuming that the total marks obtained for the examination are 540 answer the following questions:

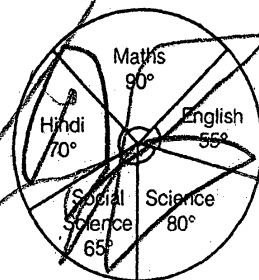

- The marks scored by the student in Hindi and Mathematics exceed the marks scored in English and Social Science by
 - 60
 - 75
 - 40
 - 30
- The subject in which the student scored 22.2% marks is
 - Hindi
 - Science
 - Social Science
 - English
- The subject in which the student scored 105 marks is
 - Mathematics
 - Hindi
 - Science
 - Maths
- The marks obtained in the three subjects : English, Science and Social Science are what percentage of the total?
 - 45%
 - $44\frac{4}{9}\%$
 - 55%
 - $55\frac{5}{9}\%$
- The marks obtained in Mathematics are what percentage of the total marks?
 - 20%
 - 30%
 - 35%
 - 25%
- The difference of marks between English and Social Science is the same as between
 - Science and Hindi
 - Hindi and Social Science
 - English and Hindi
 - Social Science and Science
- The aggregate marks obtained by the students averaged over the 5 subjects is
 - 72
 - 108
 - 90
 - 75

Direction (Qs. 8 to 12): Use the following chart to answer these questions on the age-wise distribution of personal income of a country in the year 2002.

Rs. 2499.4 Billions = 100%

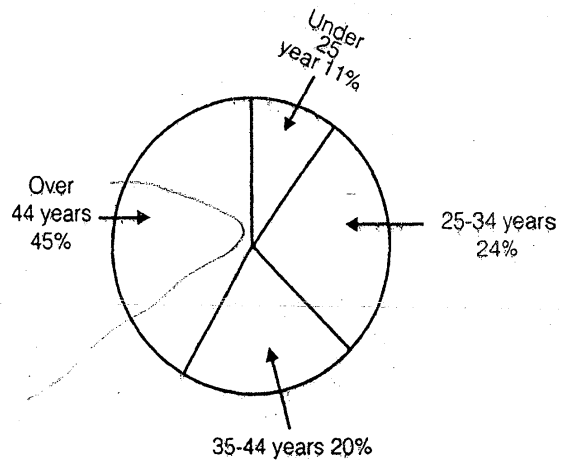

- In 2002, what was the approximate personal income, in billions of rupees, of the age-group 35-44 years?
 - 500
 - 600
 - 1125
 - None of these
- About how many degrees are there in the central angle devoted to the personal income of the age group 35-44
 - 20
 - 40
 - 72
 - None of these
- What is the ratio of the personal income of the age group 25-34 to that of the age-group 35-44?
 - 9 : 4
 - 5 : 6
 - 8 : 15
 - None of these
- If the total income in 2002 was 20 percent greater than it was in 2000, then what was the approximate total personal income in 2000 (in billions of rupees)?
 - 2200
 - 2100
 - 2000
 - None of these
- If the total income in the year 2007 is projected to be one-and-a-half time of its current size, then what is the assumed annual compound rate of growth in income (in percent)?
 - 20%
 - 25%
 - 30%
 - 35%

- (a) 20
(c) 15

- (b) 25
(d) None of these

Direction (Qs. 13 to 17): These question are based on the following pie chart showing percentage of money spend on household items by a representative family :

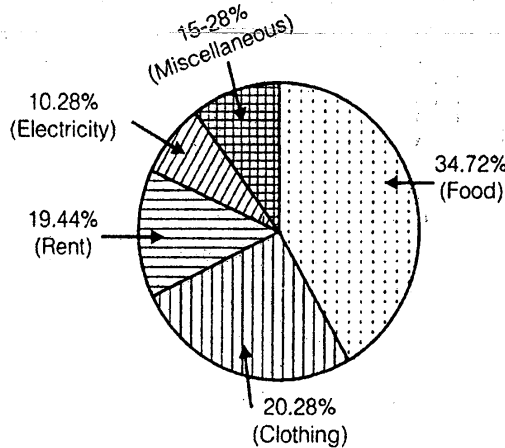

13. The ratio between the money spent on Rent and Food is
(a) 1 : 2 (b) 7 : 5
(c) 14 : 25 (d) None of these
14. If the income of a family is Rs. 12000 p.m. then the difference between the expenditure (in rupees) on Clothing and Electricity is nearly
(a) 8700 (b) 4400
(c) 3300 (d) None of these
15. If the income of a family is Rs. 20,000 p.m. then the ratio of the expenditure on Rent and Miscellaneous items is
(a) 3 : 2 (b) 7 : 5
(c) 7 : 6 (d) None of these
16. If the income of a family increase by Rs. 1000 p.m., then the amount spent (in rupees) on Electricity should increase by nearly
(a) 100 (b) 200
(c) 300 (d) None of these
17. If the income of a family is Rs. 8000 p.m., then the approximate difference of the expenditure on Electricity and Miscellaneous items is (in percent)

- (a) 18
(c) 5

- (b) 12
(d) None of these

Direction (Qs. 18 to 22): Study the following information to answer the given questions.

Percentage of students in various courses (A,B,C,D,E,F) in the pie chart-I and percentage of girls in pie Chart-II

Total students : 1200
(800 girls + 400 boys)

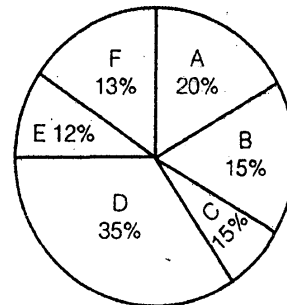

Chart-I

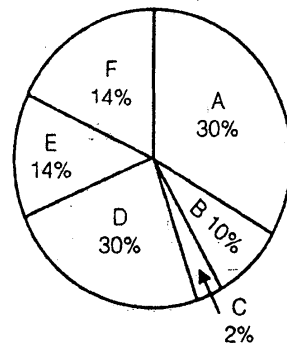

Chart-II

18. For course D, what is the respectively ratio of boys and girls?
(a) 3 : 4 (b) 4 : 5
(c) 3 : 5 (d) 5 : 6
(e) None of these
19. For which pair of course is the number of boys the same?
(a) E and F (b) A and D
(c) C and F (d) B and D

... the number of girls is how much per cent more than the number of boys for course E?

- (a) 250 (b) 350
(c) 150 (d) 80
(e) None of these

21. For which course is the number of boys the minimum?

- (a) E (b) F
(c) C (d) A
(e) None of these

22. How many girls are there in course C?

- (a) 44 (b) 16
(c) 40 (d) 160
(e) None of these

Direction (Qs. 23 to 27): The circle graph here show the spending by a family on various items during the year 1999. Study the graph and answer these questions.

Percent of money spent by a family on various items during 1999

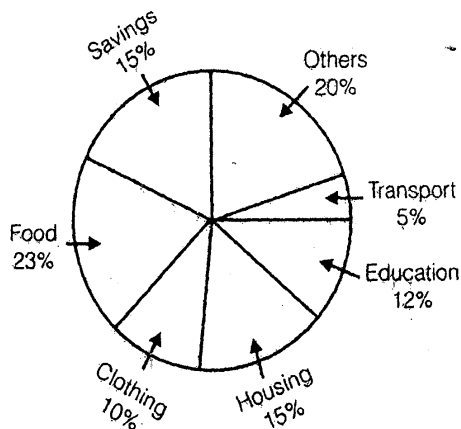

23. If the total amount spend during the year 1999 was Rs. 46000, the amount spent on food was

- (a) Rs. 2000 (b) Rs. 10580
(c) Rs. 23000 (d) Rs. 2300

24. If the total amount spend was Rs 46000, how much money was spent on clothing and housing together?

- (a) Rs. 11500 (b) Rs. 1150
(c) Rs. 10000 (d) Rs. 15000

25. The ratio of the total amount of money spent on housing to that spent on education was

- (a) 5 : 2 (b) 2 : 5
(c) 4 : 5 (d) 5 : 4

26. Graph shows that the maximum amount was spent on

- (a) Food (b) Housing
(c) Clothing (d) Others

27. If the total expenditure of the family for the year 1999 was Rs. 46000, the family saved during the year

- (a) Rs. 1500 (b) Rs. 15000
(c) Rs. 6900 (d) Rs. 3067 approx

Solutions

Answer 1 to 5:

1. (a) Marks scored in Hindi and Maths

$$= \frac{160}{360} \times 540 = 240$$

Marks scored in English and Social Science

$$= \frac{120}{360} \times 540 = 180.$$

2. (b) $100\% = 360^\circ$

$$22.2\% = \frac{360}{100} \times 22.2 = 79.92^\circ = 80^\circ.$$

3. (b) $540 = 360^\circ$

$$105 = \frac{360}{540} \times 105 = 70^\circ.$$

4. (d) $360^\circ = 100\%$

$$200^\circ = \frac{100}{360} \times 200 = 55\frac{5}{9}\%.$$

5. (d)

6. (d)
7. (b)
Average = 72°
 $360^\circ = 540$
 $72^\circ = \frac{2499.4}{5} \times 72 = 108.$
8. (a) 20% of 2499.4 billions
 $= \frac{2499.4}{5} = 499.88 = 500 \text{ billion.}$
9. (c)
10. (d)
11. (b) Total personal income in 2002 = 2499.4 billion
Total personal income in 2000 = x , say
 $\therefore x = 20\% \text{ of } x = 2499.4$
 $\Rightarrow x = \frac{5}{6} \times 2499.4 = 2082.83 = 2100.$
12. (d) Total income project in the year 2007 = 150, when the income in the year 2002 was 100.
 \therefore Annual compound rate of growth is 8.5%
13. (c) Ratio between the money spent on rent and food
 $= \frac{19.44}{34.72} = \frac{1944}{3472} = \frac{14}{25}$
14. (d) Expenditure on clothing = 20.28% of Rs 12000 = Rs 2433.60
Expenditure on electricity = 10.28% of 12000 = Rs 1233.60
= Required difference = Rs 1200.
15. (d) Required ratio = $\frac{19.44}{15.28} = 1.27,$
Whatever the family income may be
16. (a) Amount on electricity will increase by Rs 102.80 = Rs. 100.
17. (c) Required difference will be 15.28% - 10.28% = 5%, whatever the family income may be
18. (a) Total no. of students for course D = 35% of 1200 = 420
No. of girl students for course D = 30% of 800 = 240
No. of boy students for course D = 420 - 240 = 180
Reqd. ratio = 180 : 240 = 3 : 4
19. (c) No. of boys of difference course are
A = 0; B = 100; C = 44; D = 180; E = 32; F = 44.
20. (a) No. of girls for course E = 14% of 800 = 112
No. of boys for course E = 32
Reqd more % = $\frac{112-32}{32} \times 100 = 250\%$
21. (d) Using the information given in Q. No. (ii)
22. (b) No. of girls in course C = 2% of 800 = 16.
23. (b) 23% of 46000 = Rs. 10580
24. (a) 25% of 46000 = Rs. 11500
25. (d) Required ratio = 15 : 12 = 5 : 4
26. (a) 23%
27. (c) 15% of 46000 = Rs. 6900

□□□□



Practice Exercise: II

Direction (Qs. 1 to 7): The following pie chart (Fig. 1.30) shows the amount of subscription generated for the India Bonds from different categories of investors.

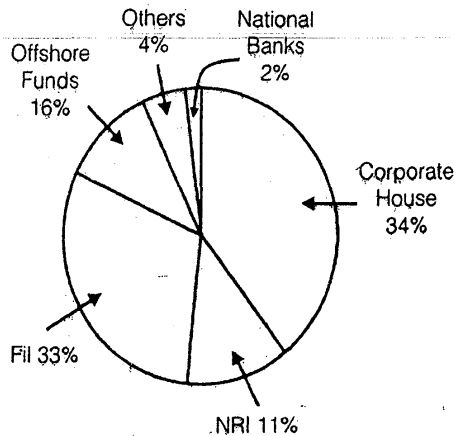

- If the investments by NRI's are Rs. 4,000 crore, then the investment by houses and FIIs together is:
 - 24,000 crore
 - 24,363 crore
 - 25,423.4 crore
 - 25,643.3 crore
- What percentage of the total investment is coming from either FIIs or NRIs?
 - 33%
 - 11%
 - 44%
 - 22%
- If the total investment other than by FII and corporate house is Rs 335,000 crore, then the investment by NRIs and Offshore funds will be (approximately):
 - 274,100
 - 285,600
 - 293,000
 - Cannot be determined
- What is the approximate ratio of investment flows into India Bonds from NRIs to corporate houses?
 - 1 : 4

- 1 : 3
- 3 : 1
- Cannot be determined

- In the corporate sector, approximately how many degrees should be there in the central angle?
 - 120
 - 121
 - 122
 - 123
- If the total investment flows from FIIs were to be doubled in the next year the investment flows from all other sources had remained constant at their existing levels for this year, then what would be the proportion of FII investment in the total investment flows into India Bonds in the next year? (Approximately)
 - 40%
 - 50%
 - 60%
 - 70%
- If the inflow from the FIIs after the doubling (Of Question 6) where to the tune of US\$ 500 million what would be the total investment into India Bonds next year (in US\$ millions)
 - 1000
 - 1500
 - 800
 - Cannot be determined

Direction (Qs. 8 to 13): (A) and (B) exhibit the distribution of the overseas tourist traffic from India. The two charts show the tourist distribution by country and the age wise traffic of the tourist respectively. Study the charts carefully and answer the question which flow.

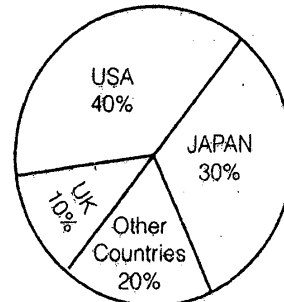

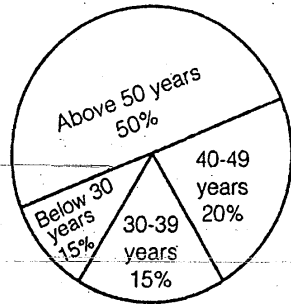

8. What percentage of the India tourist went to either USA or UK?
 (a) 40% (b) 50%
 (c) 60% (d) 70%
9. The ratio of the number of Indian tourists that went to USA to the number of Indian tourists who were below 30 years of age is :
 (a) 2 : 1
 (b) 8 : 3
 (c) 3 : 8
 (d) Cannot be determined
10. If amongst other countries, Switzerland accounted for 25% of the Indian tourist traffic, and it is known from official Swiss records that a total of 25 lakh Indian tourist had gone to Switzerland during the year, then find the number of 30-39 years-old Indian tourists who went abroad in that year
 (a) 18.75 lakh (b) 25 lakh
 (c) 50 lakh (d) 75 lakh
11. For Question 10, what was the volume of traffic of Indian tourists in the US?
 (a) 150 lakh (b) 125 lakh
 (c) 200 lakh (d) None of these
12. For Questions 10 and 11, what can be inferred about the number of 50 + year-old who visited UK during the year?
 (a) At least 25 lakh
 (b) Exactly 25 lakh
 (c) At least 10 lakh
 (d) Cannot be determined

13. Solve question 12 assuming that the age distribution of overseas Indian tourists was uniform for all the countries
 (a) At least 25 lakh
 (b) Exactly 25 lakh
 (c) At least 10 lakh
 (d) Cannot be determined

Direction (Qs. 14 to 18): Pie Chart given below shows the expenditure incurred in bringing out a book by a publisher

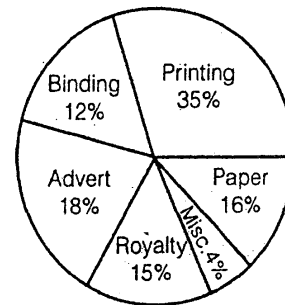

Study the graph carefully and answer the questions given below

14. What is the central angle of the sector for the cost of the paper?
 (a) 22.5° (b) 16°
 (c) 54.8° (d) 57.6°
15. If the cost of printing is Rs. 17500, the royalty is :
 (a) Rs. 8750 (b) Rs. 7500
 (c) Rs. 3150 (d) Rs. 6300
16. If the miscellaneous charges are Rs. 9000, the advertisement charges are:
 (a) Rs. 13500 (b) Rs. 20000
 (c) Rs. 40500 (d) Rs. 1800
17. If 5500 copies are published and miscellaneous expenditure on them amount to Rs. 5544 and the publisher earns a profit of 25%, then marked price of each copy is :
 (a) Rs. 25.20 (b) Rs. 37.50
 (c) Rs. 31.50 (d) Rs. 30

18. Royalty on the book is less than the advertisement charges by :

- (a) 3% (b) $16\frac{2}{3}\%$
 (c) 20% (d) None of these

Direction (Qs. 19 to 23): The gross investment of Life Insurance Corporation of India (in crores of rupees) in different sectors are shown in the pie chart given below :

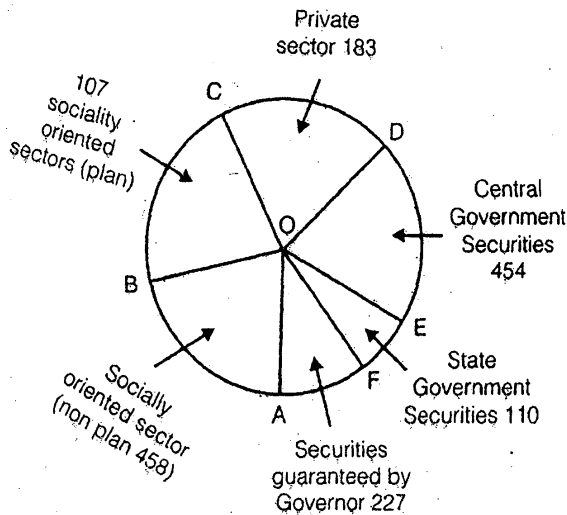

On the basis of the above information answer the following questions.

19. The percentage of gross investment in States Government Securities is nearly :
 (a) 7.1% (b) 7.8%
 (c) 8.6% (d) 9.2%
20. The magnitude of $\angle AOC$ is nearly :
 (a) 103° (b) 132°
 (c) 126° (d) 115°
21. The investment in socially oriented sectors (plan and non plan) is than the investment in Government securities (Central and State) by ...
 (a) More, 4 crore (b) More, 1 crore
 (c) More, 111 crore (d) Less, 106 crore

22. The investment in private sectors is nearly... percent higher than the investment in State Government Securities?

- (a) 66 (b) 54
 (c) 46 (d) 40

23. The ratio of the area of the circle above COF to the area of the circle below it is, nearly :

- (a) 1 (b) 0.966
 (c) 0.94 (d) 0.92

Solutions

Answer 1 to 5 :

- (b) $(67/11) \times 400$
- (c) $33 \div 11 = 44$
- (a) Investment other than NRI and corporate houses is 33% = 335000. Also, investment by offshore funds and NRIs is equal to 27%. Hence, $27 \times 335,000/33$.
- (b) $11 : 34$ is approximately equal to $1 : 3$
- (c) $34 \times 3.6 = 122.4$ (since $1\% = 3.6$ degrees).
- (b) FIs currently account for 33 out of 100. If their value is doubled and all other investments are kept constant then their new value would be 66 out of 133 \rightarrow approximately equal to 50%
- (a) 500 million would be approximately 50% of the total investment. Then 1000 will be the total investment.
- (b) $40 + 10 = 50\%$ (from the first chart)
- (b) $40 : 15 = 8 : 3$
- (d) 5% corresponds to Switzerland's 25 lakh. Hence 15% will be 75 lakh
- (c) US account for 40%, i.e., 8 times 5%. Since, Switzerland's 5% is 25 lakh, US will be 200 lakh

12. (d) Nothing can be said about the age break-up of the Indian tourists who have gone to any destination. Hence, cannot be determined.

13. (b) If the age distribution is uniform, then 50 + - year-olds who went to UK., i.e., 25 lakh based on Swtzerland's value from question 10.

14. (d) Central angle for the cost of the paper

$$= \left(\frac{16}{100} \times 360 \right)^\circ = 57.6^\circ.$$

15. (b) Let the royalty be Rs. x . Then
35 : 15 :: 17500 : x or

$$x = \left(\frac{15 \times 17500}{35} \right) = \text{Rs. } 7500$$

16. (c) Let the advertisement charges be Rs. x .

$$\text{The, } 4 : 18 :: 9000 : x \text{ or } x = \left(\frac{18 \times 9000}{4} \right) \\ = \text{Rs. } 40500.$$

17. (c) Let the total charges be Rs. x .
Then, 4 : 100 :: 5544 : x or x

$$= \left(\frac{18 \times 5444}{4} \right) = \text{Rs. } 138600.$$

∴ Total cost = Rs. 138600.

∴ Cost price of each copy

$$= \text{Rs. } \left(\frac{138600}{5500} \right) = \text{Rs. } 25.20.$$

∴ Marked price = 125% of Rs. 25.20

$$= \text{Rs. } \left(\frac{125}{100} \times 25.20 \right) = \text{Rs. } 31.50$$

18. (b) Let royalty be Rs. 15. Then, advertistment charges = Rs. 18.

$$\therefore \text{ Required percentage} = \left(\frac{3}{18} \times 100 \right) \%$$

$$= \text{Rs. } 31.50$$

19. (a) Total investment = (458 + 107 + 183 + 454 + 110 + 227) crores

$$\therefore \text{ Required percentage} = \left(\frac{110}{1539} \times 100 \right) \%$$

$$= 7.1\%$$

$$20. (b) \angle \text{AOC} = \left[\frac{(458 + 107) \text{ crores}}{1539 \text{ crores}} \right]$$

$$= \left(\frac{565}{1539} \times 360 \right) = 135^\circ.$$

21. (b) Investment in socially oriented sectors = (458 + 107) crores = 565 crores.

∴ Investment in socially oriented sectors is more than investment in Government securities by 1 crore.

22. (a) Investment in Private Sector = 183 crores.
Investment in State Government Securities = 110 crores.

$$\therefore \text{ Required excess} = \left(\frac{73}{110} \times 100 \right) \%$$

$$= 66\%$$

23. (c) Required Ratio

$$= \frac{(183 + 454 + 110)}{107 + 458 + 227} = \frac{747}{792}$$

$$\Rightarrow \frac{83}{88} = 0.943$$





Miscellaneous Puzzles

Puzzles

A puzzle is a problem or enigma that tests the ingenuity of the solver. In a basic puzzle one is intended to piece together objects (puzzles pieces) in a logical way in order to come up with the desired shape, picture or solution.

Solutions to puzzles may require recognizing patterns and creating a particular order. People with a high inductive reasoning aptitude may be better at solving these puzzles than others.

Types of Puzzles

The large number of puzzles that have been created can be divided into various categories for example logical puzzle using chess board.

Other categories include

- Mathematical problem such as the missing square puzzle
- Picture puzzle.
- Connect the dots
- Logical puzzle like Sudoku.
- Spot the difference etc.

Lets have a glimpse of different types of puzzles

Numbers

Ex.1 In a ten digit number first digit represent number of one present in the number. Second digit represent number of two present in the number. Similarly, third digit represent number of three present in the number and so on till ninth digit, which represent number of nine present in the number. Last digit represent number of zero present in the number. Find that number.

Sol.: Let the ten digit number be

a_1	a_2	a_3	a_4	a_5	a_6	a_7	a_8	a_9	a_0
-------	-------	-------	-------	-------	-------	-------	-------	-------	-------

The smallest possible ten digit number is 1,00,00,00,000

We will go on modifying this number, since last digit represent number of zeros it should be 9.

1st step : 1,00,00,00,009.

Since we have only 8 zeros last digit should be 8.

IInd step : 1,00,00,00,008

Since number of "8" present in the above case is one the next modification will be.

IIIrd step : 1,00,00,00,108.

Here number of zeros are only seven so

IVth step : 1,00,00,00,107.

Here, since the number of "7" present is one so next modification will be

Vth step : 1,00,00,01,007.

Here, since number of "1" present is two and after writing "2" in first place number of "2" present will be one so next modification is

VIth step : 2,10,00,01,007

Here, since number of zeros present is six so next modification will be

VIIth step : 2,10,00,01,006.

Here, since number of "6" present is 1 so next modification will be

VIIIth step : 2,10,00,10,006.

This number 2,10,00,10,006 satisfy all the condition so this is the desired number.

$$\Delta ADB = \Delta 1 + \Delta 2$$

$$\Delta ADC = \Delta 1 + \Delta 2$$

$$\Delta BDC = \Delta 3 + \Delta 4$$

$$\Delta ABC = \Delta 2 + \Delta 3$$

So in the give (1) we will have 12 such "double" triangles.

Now, we will count number of triangles made by joining four triangles.

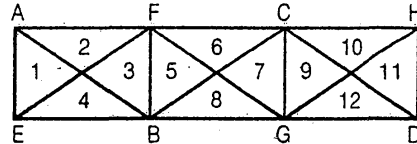

$$\Delta ABC = \Delta 2 + \Delta 3 + \Delta 5 + \Delta 6$$

$$\Delta EFG = \Delta 4 + \Delta 3 + \Delta 5 + \Delta 8$$

$$\Delta BCD = \Delta 8 + \Delta 7 + \Delta 9 + \Delta 12$$

$$\Delta FGH = \Delta 6 + \Delta 7 + \Delta 9 + \Delta 10$$

So we have

12 "single" triangle

12 "Double" triangle and

4 "four" triangle

⇒ 28 triangle Ans.

Triangles

Ex.2 Find out the total number of triangles in the given figure.



Sol. First of all we will count single triangle.
Number of single triangle = 12

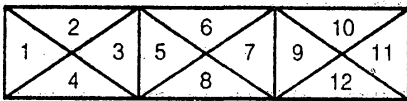

Now, we will count triangle made by joining two triangles for example in the above figure we have 4 triangles made by joining two single triangles.

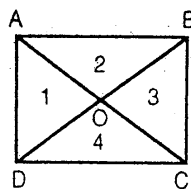

Ex.3 Find number of triangles present in above Fig. (5).

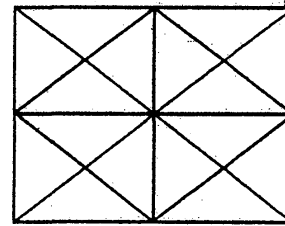

Sol. Number of "single" triangles present the Fig. (6) are 16.

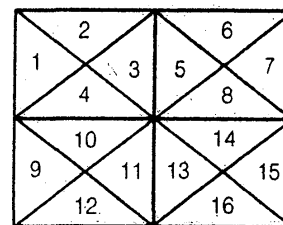

Now, we will find number of double triangles in Fig. (7) which is 4.

So total "double triangle" are 16.

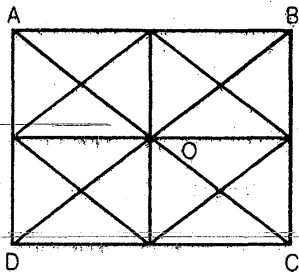

Number of "four triangles" will be 4.

$\triangle AOD$

$\triangle AOB$

$\triangle BOC$

$\triangle DOC$

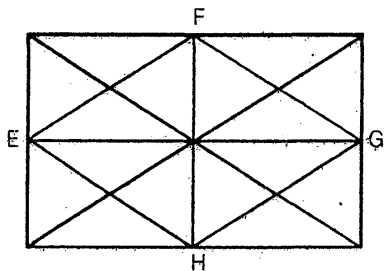

Number of "four triangles" will be 4

$\triangle EFH$

$\triangle EFG$

$\triangle FGH$

$\triangle EHG$

Number of "Eight Triangles" will be Four

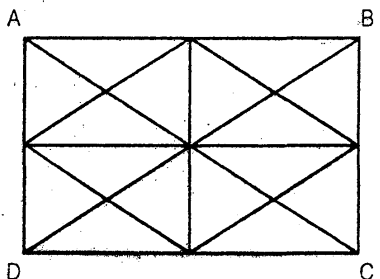

$\triangle ABC$

$\triangle BCD$

$\triangle CDA$

$\triangle DAB$

So, total number of triangle will be

$$16 + 16 + 4 + 4 + 4 = 44 \text{ Ans.}$$

Temple and Tank

Ex.4 There are three temples near Tanjaur. In front of all temples there is one tank each. Kavitha, a lady deity goes to temple with certain number of flower. She wash flowers in tanks in front of first temple and it become double. She devoted 8 flower in that temple and moved to second temple. She again wash remaining flowers and it again become doubled. She devoted 8 flowers in the second temple. She again wash flower in third tank in front of the last temple and devoted 8 flowers. Now she is left with no flowers. How many flowers Kavitha initially had?

Sol.

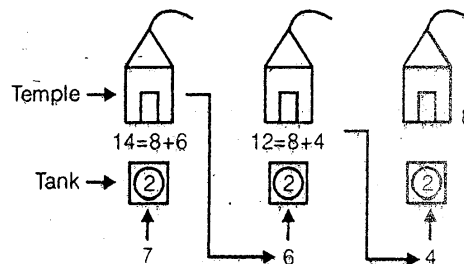

- (1) We will start solving it from back side. After devoting 8 flowers in third temple Kavitha had no flowers. It means before washing in third tank she had 4 flowers.
- (2) It also shows that she had 12 flower before devoting 8 flower in second temple.
- (3) From this information we come to know that she had 6 flowers before washing it in second tank.

- (4) It means she had $(8 + 6) = 14$ flowers before devoting to first temple.
- (5) Now we can easily get the number of flower she initially had before washing in first tank.
- (6) From the above Fig. we can easily find solution in a simple and lucid manner.

- 34 i.e. $24 + 10$ mouse came out of second whole, 24 become diet of cat and 10 remained.
- 17 mouse entered into second whole.
- 41 mouse came out of first whole.
- There were 41 mouse before entering into first whole.

Cat and Mouse

Ex.5 There are four wholes numbered 1, 2, 3 and 4. The unique properties of these wholes is that number of mouse become double, triple and four times after entering into whole number 2, 3 and four respectively. While it remains same if they enter in first whole. One cat is running in search of few mouse. To save themselves from cat, mouse entered in first whole and came out. 24 of them become diet of cat. They respectively entered into second, third and fourth whole and come with double, triple and four times in number. After their exit from each whole i.e. second third and fourth, 24 become diet of cat everytime. At the end there is no mouse left. Find the initial number of mouse before entering into first whole.

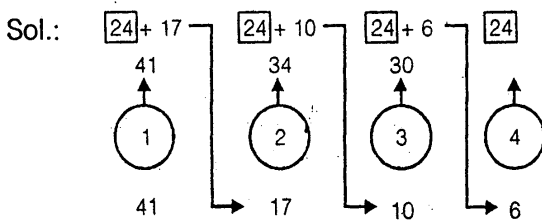

- From the fig it is clear that before entering into fourth whole there were 6 mouse.
- 30 mouse came out of fourth whole, because 24 become diet of cat and 6 remained.
- before entering into third whole there were 10 mouse.

Rectangles

Ex.6 Six parallel horizontal lines are intersecting perpendicularly to six verticle parallel lines. Find number of rectangles formed after such intersection.

Sol.:

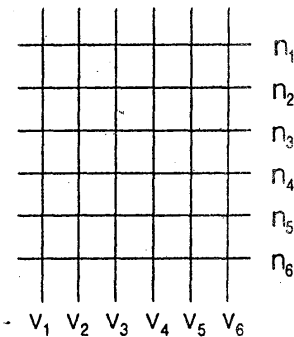

Here V_1 to V_6 represent six parallel vertical lines and h_1 to h_6 represent six parallel horizontal lines.

To form a rectangle we need to select any two horizontal parallel lines which intersect any two vertical parallel lines.

Thus

$${}^6C_2 \times {}^6C_2 = 15 \times 15 = 225$$

225 rectangle will be formed.

Birthday Cake

Ex.7 In a Birthday party there is a cake of negligible thickness, which is to be cut into different pieces. How many maximum pieces are possible if five cuts are made?

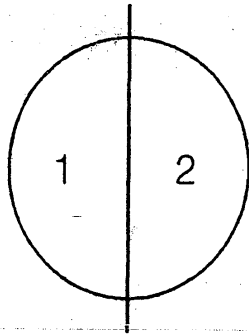

[Fig. First cut]

Total pieces = $1 + 1 = 2$

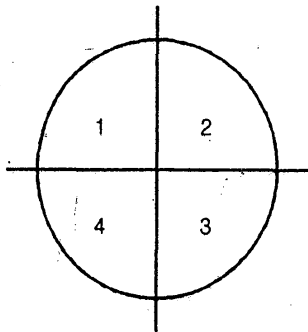

[Fig. Second cut]

Total pieces = $1 + 1 + 2 = 4$

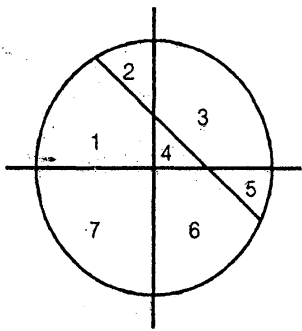

[Fig. Third cut]

Total pieces = $1 + 1 + 2 + 3 = 7$

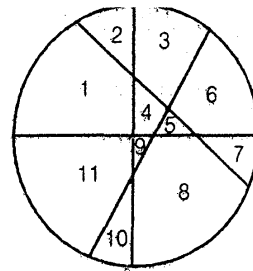

Fig. Fourth cut

Total pieces = $1 + 1 + 2 + 3 + 4 = 11$

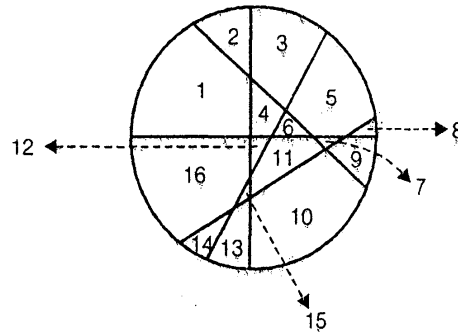

Fig. Fifth cut

Total pieces will be
 $= 1 + 1 + 2 + 3 + 4 + 5 = 16$ Ans.

Similarly, for n cuts we get
 $1 + 1 + 2 + 3 + 4 \dots n$ pieces.

$\Rightarrow 1 + \Sigma n$ pieces.

$\Rightarrow 1 + \frac{n(n+1)}{2}$ pieces.

Intersecting Lines

Ex. 8 Five lines are intersecting each other. Find maximum how many intersecting points are possible.

Sol.

1. Single line

no intersecting points

2. Two lines

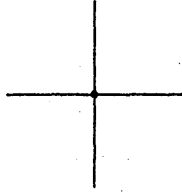

One intersecting point $\Rightarrow 0 + 1 = 1$

3. Three lines

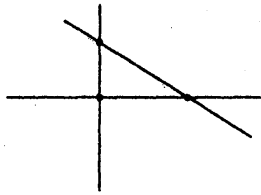

Three intersecting points $\Rightarrow 0 + 1 + 2 = 3$

4. Four lines

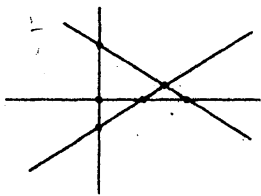

Six intersecting points $\Rightarrow 0 + 1 + 2 + 3 = 6$

5. Five Lines

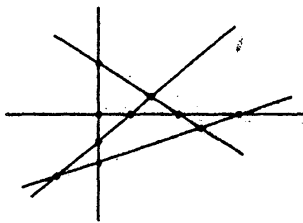

Ten intersecting points
 $\Rightarrow 0 + 1 + 2 + 3 + 4 = 10$

Similar for n intersecting lines, maximum
intersecting points will be

$$0 + 1 + 2 + 3 + \dots (n - 1) = \Sigma (n - 1)$$

Coins

Ex.9 Ten coins are to be placed in five lines in such a manner that each line contains four coins.

Sol. 1. Triangles

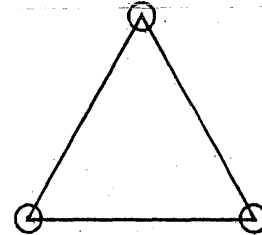

Triangle represents a figure in which three coins are placed in three lines such that each line contains two coins.

2.

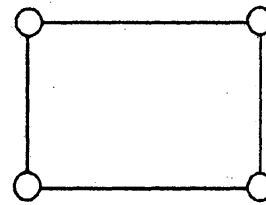

Square or rectangle represents a figure in which four coins are placed in four lines such that each line contains two coins.

3.

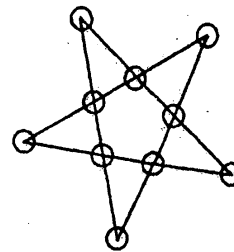

Star represents a figure in which ten coins are placed in four lines such that each line contains four coins.

4.

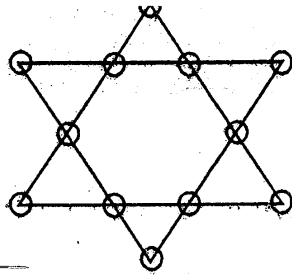

Similarly we can observe in given figure that twelve coins are present in six lines such that each lines contains four coins.

The Flag

Ex.10 Flag of a nation consists of six different strips. How many such flags can be possible if we use six colours to fill the strips such that no two consecutive strips will have same colours?

Sol.

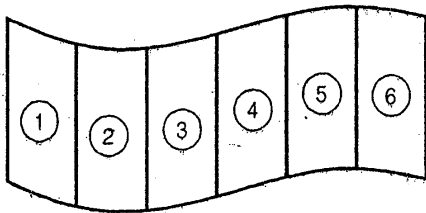

First strip can be filled with any six colours. Next strip can be filled with any five colours except the colour filled in strip one. Successive strips will also be filled in the same manners. Number of possible flags will be

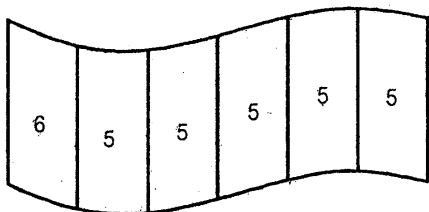

$$6 \times 5 \times 5 \times 5 \times 5 = 18750 \text{ Ans.}$$



Direction (Qs. 1 to 3): Read the following information carefully and answer the question below it.

Rahul brought some sweets on his 21st birthday. He offered one less than the half of total number sweets in the temple near the house. He also gave one sweet each to 3 beggars sitting on the stairs of 'temple'. On the way back to home, he stopped a big group of poor children and gave them half of what was left with him. After reaching home he shared of the remaining two pieces of sweets with his younger brother.

- How many sweets did he originally had?
(a) 8 (b) 10
(c) 12 (d) 14
- How many sweets did he offered in the temple?
(a) 3 (b) 4
(c) 5 (d) 6
- How many sweets did he gave to poor children?
(a) 1 (b) 2
(c) 30 (d) 42

Direction (Qs. 4 to 8): Read the following information carefully and answer the question below it.

Study the pyramid of the letters given below and answer the questions

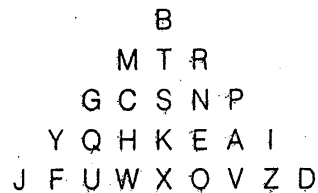

- Which letter is missing in the pyramid?
(a) F (b) I
(c) L (d) P

5. If letters were to be studied vertically, which two letters happen to be neighbours that occur together in alphabetical order
 (a) WX (b) PR
 (c) UV (d) ST
6. In order to form word, one of the letters in the pyramid is always followed by one particular letter and that letter is just underneath it. Which is not this pair?
 (a) NE (b) PA
 (c) ZI (d) QU
7. Two letters in the above pyramid have exactly the same number of letters between them horizontally as they have in the alphabetical order. Which are they?
 (a) Y and Q (b) V and X
 (c) N and P (d) E and K
8. If all the horizontal lines were to be studied separately which neighbours in the alphabetical order are the farthest?
 (a) F and U (b) Q and Y
 (c) C and S (d) H and Q

Direction (Qs. 9 to 16): Read the following information carefully and answer the question below it.

The Selection Committee of a company laid down the following criteria of selection for the post of Manager-Accounts:

- (i) The candidate must be a post-graduate in Commerce.
- (ii) The candidate must have completed 21 years and should not be more than 35 years as on 31-07-1996.
- (iii) If the candidate does not satisfy the criterion in (i) above but has completed his CA examination he will be referred to Director - Finance, who can allow the candidate to appear in the interview if otherwise eligible.

- (iv) If the candidate fulfils all the criteria mentioned in (i) and (ii) above, he/she will be called for group discussion.
- (v) The candidate must get 50% marks to qualify in the group discussion.
- (vi) If the candidate qualifies in the group discussion he/she will be called for interview.
- (vii) The candidate must get 30% marks in the interview (out of 50) to get finally selected.

Based on the above criteria, decide which of the following course of action should be taken in the case of candidate described in each of the following questions.

Mark answer as:

- (1) If the candidate can be selected;
 - (2) If the candidate is to be referred to Director - Finance;
 - (3) If the candidate can be called for group discussion;
 - (4) If the candidate can be called for interview;
 - (5) If the candidate cannot be selected
9. Mr. Das is M.Com and his date of birth is 30-06-1961
10. Mrs. Krishnamurthy is a qualified CA and was 25 years old on 31-07-1996
11. Mr. Kant, a post-graduate with Commerce obtained 70% marks in group discussion and secured 20 marks in Interview. He was 35 years as on 31-07-1996
12. Mrs. Desai is a post-graduate in Economics and her date of birth is 3-04-1965
13. Mr. Patel, a post-graduate was permitted by Director - Finance. He was born on 30-05-1963. He obtained 12 marks in interview

years old on 1-08-1995. He obtained 14 marks in interview.

15. Mr. Roy is a commerce graduate, has passed his CA examination and was born on 18-04-1974.
16. Mr. Subramaniam whose date of birth is 04-05-1965 is a post graduate with Commerce and has obtained 60% marks in the interview

Direction (Qs. 17 to 21): Read the following information carefully and answer the question below it.

Three small children Sonu, Monu and Tonu went on a picnic with their dog Jhony. They carried with them few chocolates, which none of them incidentally counted on their way. They rested under a tree and slept for a while. After some time Sonu woke up, gave one chocolate from the total to Jony and distributed the remaining into three equal parts, ate his share and slept. After some time, Monu woke up, gave one chocolate to Jony and distributed that remaining into three equal parts, ate his share and slept. After some time Tonu woke up and repeated the same. A little later all of them woke up together, gave one chocolate from the total to Jhony and divided the remaining chocolates among them and each one ate his share. By chance we know that the total number of chocolates were less than 150 in the beginning and they didn't break any chocolate.

17. How many chocolates were in the beginning?
(a) 66 (b) 84
(c) 118 (d) 79
18. What is the difference in the number of chocolates eaten by Monu and Tonu?
(a) 6 (b) 11
(c) 14 (d) 18
19. What is the difference in the number of chocolates eaten by Sonu and Tonu?
(a) 25 (b) 15
(c) 20 (d) 18

ratio...

- (a) 13 : 11 (b) 9 : 7
(c) 4 : 3 (d) 5 : 4

21. How many more chocolates did monu eat, than Jhony?

- (a) 20 (b) 27
(c) 32 (d) 36

Direction (Qs. 22 to 26) : Read the following information carefully and answer the question below it

Atul, Bhupinder, Charles and Deepak are four brothers playing a game where the loser doubles the money of each of the other players. They played four games and each brother lost one game in alphabetical order. At the end of the fourth game each brother had Rs. 64.

22. Who started with the lowest amount?

- (a) Atul (b) Bhupinder
(c) Charles (d) Deepak

23. What was the amount left with Charles at the end of the second round?

- (a) 72 (b) 144
(c) 132 (d) 136

24. How many rupees did Bhupinder start with?

- (a) 64 (b) 136
(c) 68 (d) 72

25. At the end of the fourth round, who had the max. profit? (max. wining vis-a-vis opening amount)

- (a) Atul (b) Bhupinder
(c) Charles (d) Deepak

26. Who had the minimum deviation from the opening amount?

- (a) Atul (b) Bhupinder
(c) Charles (d) Deepak

Direction (Qs. 27 to 29): Read the following information carefully and answer the question below it.

Life was not easy before Aryabhata. Zero was not invented and also people could not multiply numbers. Thus mathematics had only 9 digits (1 to 9) and after that came 11 and so on. Find the answer to following operations in mathematics used then.

27. What is $7 + 11 + 3 = ?$

- (a) 20 (b) 21
(c) 22 (d) 23

28. What is $21 + 29 + 1 = ?$

- (a) 50 (b) 51
(c) 52 (d) 54

29. What is $15 + 5 + 1 + 9 = ?$

- (a) 30 (b) 31
(c) 32 (d) 33

Direction (Qs. 30 to 34): Read the following information carefully and answer the question below it.

Rahul was at a crossroads in his life. He went to an astrologer to learn what the future held for him. The astrologer explained that Rahul had many choices to make and he could only explain what each choice lead to. On leaving the astrologer, Rahul could take bus routes 213 or 231 to go to his next stop. The first led to a choice between two jobs and the second to a choice between two areas of business.

In all four cases, Rahul would go abroad and continue the same work. Rahul would marry a woman whose name begins with 'P' if he either took a job in production or had a business in readymade garments. Rahul would go to the US if he either had a job in marketing or a business in spare parts manufacture.

30. If Rahul has a wife called Pradnya and a production job, which bus did he take?

- (a) 213
(b) 231
(c) (1) or (2)
(d) cannot be determined

31. If Rahul took bus number 231 and married Rohini, what work does he do?

- (a) marketing job
(b) production job
(c) garments business
(d) spare-parts business

32. If Rahul took bus number 213 and is married to Rehana, which country does he live in?

- (a) India (b) UK
(c) US (d) Canada

33. If Rahul has a spare parts business, which of the following could be his wife's name?

- (a) Pradnya (b) Prachi
(c) Savita (d) any of these

34. If Rahul works in Australia, which of the following is possible?

- (a) Production job or spare parts business
(b) Production job, married to Poorva
(c) Garments business, married to Shruti
(d) Marketing job or garments business

Solutions

Answer 1 to 3:

Let the number of sweets be x .

Number of sweets left with him after Temple.

$$= x - \left(\frac{x}{2} - 1\right) = \frac{x}{2} + 1$$

Number of sweets left with him after giving to

$$\text{the baggers} = \frac{x}{2} - 2$$

Number of sweets left with him after giving to

$$\text{the poor children} = \frac{x}{4} - 1$$

Number of sweets left with him after giving

$$\text{his brother} = \frac{x}{4} - 2 = 1$$

This gives $x = 12$

1. (c)
2. (c)
3. (b)

Answer 4 to 8 :

4. (c) L is missing in the pyramid
5. (d) PR are not occurring together in alphabetical order. WX and UV are not vertical neighbours in a given pyramid. S.I. occur together in alphabetical order and also are vertical neighbours in a given pyramid.
6. (c)
7. (b) Y and Q; N and P; E and K are horizontal neighbours in the given pyramid, but name of these pairs occur together in alphabetical order. Both in the pyramid and in alphabetical order V and X are separated by exactly one letter.
8. (c) F and U are separated by 14 letters in an alphabetical order, while Q and Y are separated by 7 letters; C and S separated by 15 letters and H and Q are separated by 8 letters. Hence C and S are the farthest away from each other among given pairs.

Answer 9 to 16:

9. (5) Condition (ii) is not satisfied
10. (2) All the conditions of eligibility are satisfied
11. (1) All condition is are satisfied
12. (5) condition (ii) is not satisfied
13. (5) Condition satisfies all the five condition except conditon (vii)
14. (5) Condition satisfies all the five condition except conditon (vii)
15. (2) According to condition (iii) he should be refered to Director - Finance.
16. (1) Once called for interview he will be selected.

Answer 17 to 21:

Let the number of chocolates in the beginning be x.

So when Sonu woke up,

he left $\frac{2}{3}(x - 1)$ for the others.

When Monu woke up he left.

$$\frac{2}{3} \left[\frac{2}{3}(x - 1) - 1 \right] = \frac{4x - 10}{9}$$

while Tonu left = $\frac{8x - 38}{27}$

Finally they divided $\frac{8x - 38}{27} - 1$ into three equal parts.

So, $\frac{8x - 38 - 27}{27}$ or $\frac{8x - 65}{27}$ was divided

into three equal parts. This means

$\frac{8x - 65}{27}$ is divisible by 3 or $8x - 65$ is a

multiple of 81. Let $8x - 65 = 81n$ where n is an integer

So $81n + 65$ should be divisible by 8. It has to be an even number, so $81n$ should be odd number. Trying with 1, 3, 5 we get 7 and 15 as the two initial possible number but $n = 15$ will give us an initial starting number $x = 160$, which is not acceptable. So, $n = 7$ is the accepted value. So in the beginning there were 79 chocolates with the given conditions. We can distribute them accordingly. The table below show number of chocolates eaten by each.

	Sonu	Monu	Tonu	
Johny				
First	26			1
Second		17		1
Third			11	1
Last	7	7	7	1
	33	24	18	4

- 17. (d)
- 18. (a)
- 19. (b)
- 20. (c)
- 21. (a)

Answer 22 to 26:

The four brothers play in such a way that the loser doubles the money of the other players and they lose in an alphabetical order. Thus, working backwards we have Now all question can be answered

- 22. (d)
- 23. (b)
- 24. (c)
- 25. (d)
- 26. (b)

Answer 27 to 29:

Replace 10 by 11, 20 by 22 and so on.

- 27. (c) $7 + 11 + 3$ is actually $7 + 10 + 3 = 20$ which is 22
- 28. (c) $21 + 29 + 1$ is actually $19 + 27 + 1 = 47$ which is 52
- 29. (c) $15 + 5 + 1 + 9$ actually $14 + 5 + 1 + 9 = 29$ which is 32.

Answer 30 to 34:

Draw a tree of possibilities for the predictions. You can read the answer from the tree

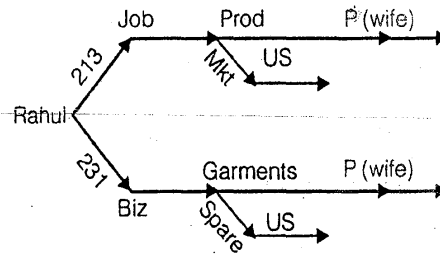

- 30. (a) Bus route 213 job in marketing go to US job in production 'P' wife Bus route 231 garments business 'P' wife' spare parts business to to US.
- 31. (d) Bus route 231, and not 'P' wife implies spare parts business.
- 32. (c) The bus number tell us that Rahul has a job, but if the wife is Rehana, it is a not a production job.
- 33. (c)
- 34. (b) As Rahul works in Australia he can do job in Production or Business in Garments and his wife's name will start P.

□□□□

Venn Diagrams

Venn Diagrams are pictorial way of representation of a set of articles. There are different regions which needs urgent attention for solving problems based on logical venn diagrams.

Case I : When there are only two articles

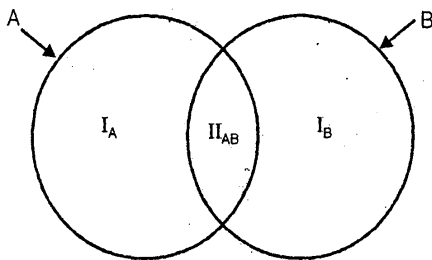

Here I_A represents A only. (i.e. not B)
 I_B represents B only (i.e. not A)
 II_{AB} represents A and B only i.e. both A and B.

Case II : When there are only three articles

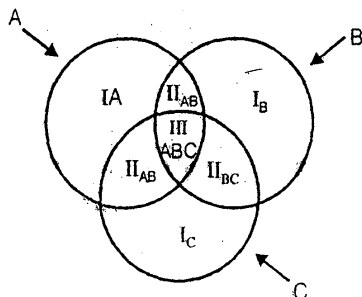

Here I_A represent A only (not B or C)
 I_B represents B only (not A or C)
 I_C represents C only (not A or B)
 II_{AB} represents A and B only (not C)
 II_{BC} represents B and C only (not A)
 II_{CA} represents C and A only (not B) and
 III_{ABC} represents A, B and C only i.e. region which is common to A, B and C.

Case III : When there are only four articles

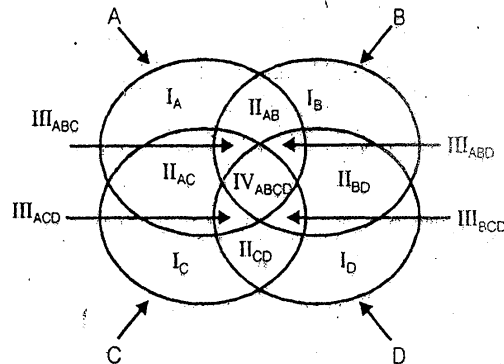

I_A represents A only (not B, C or D)
 I_B represents B only (not A, C or D)
 I_C represents C only (not A, B or C)
 I_D represents D only (not A, B or C)
 II_{AB} represents A and B only (not C or D)
 II_{AC} represents A and C only (not B or D)
 II_{BD} represents B and D only (not A or C)
 II_{CD} represents C and D only (not A or B)
 III_{ABC} represents A, B and C only (not D)
 III_{BCD} represents B, C and D only (not A)

III_{ACD} represents A, C and D only (not B)

III_{ABD} represents A, B and D only (not C)

IV_{ABCD} represents A, B C and D all.

i.e. region which is common to all A, B, C and D.

Note: A, B, C and D can be represented in form of a triangle, circle, rectangle or square. The logic behind venn diagram will remain unchanged irrespective of the type of figure.



Practice Exercise: I

- The triangle, square and circle shown below respectively represent, the urban, hard working and educated people. Which one of the areas marked I-VII is represented by the urban educated people who are not hard working?

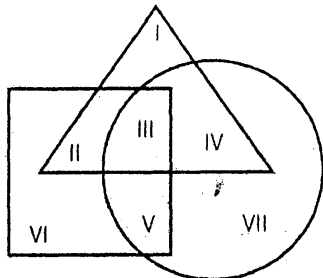

- | | |
|--------|---------|
| (a) II | (b) I |
| (c) IV | (d) III |

Direction (Question 2 to 5): The figure given below consists of three interesting circles which represent sets of students who play Tennis, Badminton and Volley Ball. Each region in the figure is represented by a small letter.

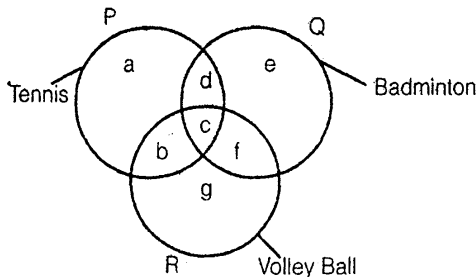

On the basis of the above figure, answer the questions given below.

- Which letter represents the set of persons who play all the three games?

(a) b	(b) c
(c) f	(d) g
- Which letter represents the set of persons who play Tennis and Volley Ball but not Badminton?

(a) g	(b) e
(c) c	(d) b
- Which letter represents the set of persons who play Tennis but neither Badminton nor Volley Ball?

(a) a	(b) b
(c) c	(d) d
- Which letter represents the set of persons who play Tennis and Badminton but not Volley Ball?

(a) b	(b) d
(c) c	(d) f
- In the given figure, the triangle represents girls, the square represents sports persons and the circle represents coaches. The portion in the figure which represents girls, who are sports persons but not coaches is the one labelled

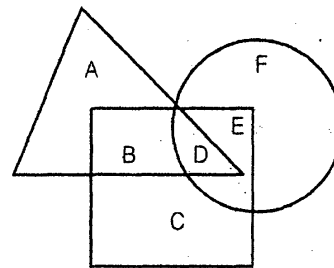

- | | |
|-------|-------|
| (a) A | (b) B |
| (c) D | (d) E |

Direction (Question 7 to 11) : Below is given a figure with four intersecting circles, each representing a group of persons having the quality written against it. Study the figure carefully and answer the questions that follow.

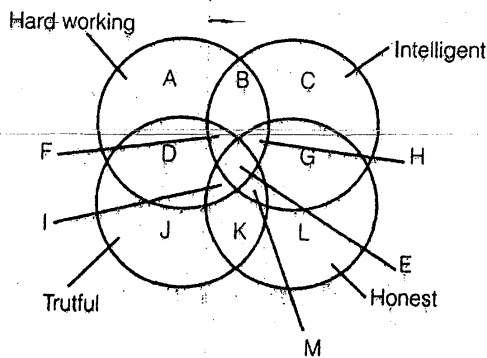

7. The region which represents the people who are intelligent, honest and truthful but not hard working is denoted by

(a) E	(b) F
(c) M	(d) I
8. The people possessing all the qualities are represented by

(a) I	(b) H
(c) F	(d) E
9. The region which represents people who are not honest but possess all other three qualities, is denoted by

(a) B	(b) d
(c) F	(d) I
10. People who are not hard working, intelligent and truthful are represented by

(a) G	(b) H
(c) K	(d) L
11. People who are not honest and truthful but are hard working and intelligent both, are represented by

(a) E	(b) B
(c) M	(d) I

12. If Tall is equivalent to circle, Armymen to triangle and Strong to square, indicate which number will represent strong armymen?

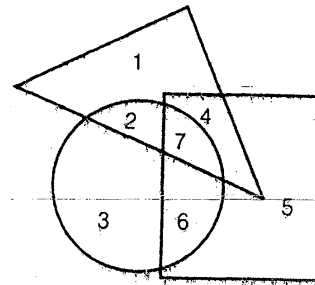

- | | |
|-------|-------|
| (a) 3 | (b) 4 |
| (c) 5 | (d) 6 |

Direction (Question 13 to 15): The following questions are based on the diagram given below. In the diagram, the triangle stands for graduates, square stands for membership of professional organisation and the circle stands for membership of social organisation. Read each statement and find out the number (s) to represent the people covered by the given statement.

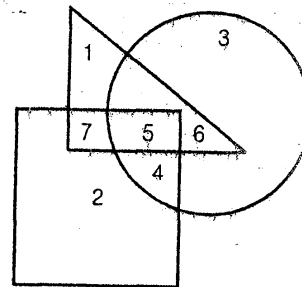

13. Number of graduates in social organisations

(a) 1	(b) 5
(c) 6	(d) 5 and 6
14. Number of a graduates in social organisations only

(a) 3	(b) 4
(c) 5	(d) 6

15. Number of graduates in professional organisations

- (a) 5 and 7 (b) 5, 6 and 7
 (c) 6 and 7 (d) 4, 5 and 6

16. In the following diagram, parallelogram represents women, triangle represents sub-inspectors of police and circle represents graduates. Which numbered area represents women graduate sub-inspector of police?

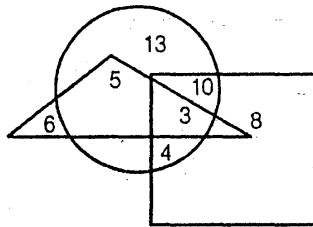

- (a) 5 (b) 3
 (c) 8 (d) 13

17. The diagram below represents the student who study Physics, Chemistry and Mathematics. Study the diagram and identify the region which represents the students who study Physics and Mathematics, but not Chemistry.

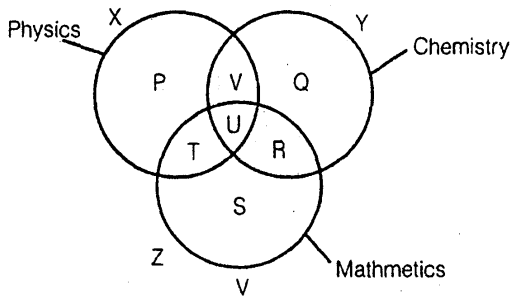

- (a) T
 (b) P + T + S
 (c) V
 (d) P + T + S + R + U + V

Direction (Questions 18 to 25) : The following questions are based on the diagram given below:

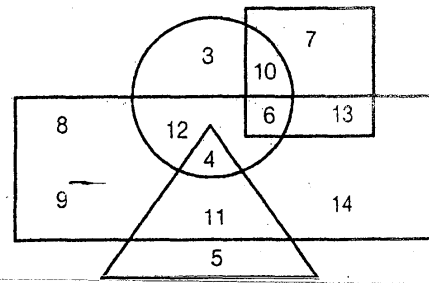

- (1) Rectangle represents males
 (2) Triangle represents educated
 (3) Circle represents urban
 (4) Square represents civil servants

18. Who among the following is an educated male who is not an urban resident?

- (a) 4 (b) 5
 (c) 9 (d) 11

19. Who among the following is neither a civil servant nor educated but is urban and not a male?

- (a) 2 (b) 3
 (c) 6 (d) 10

20. Who among the following is a female, urban resident and also a civil servant?

- (a) 6 (b) 7
 (c) 10 (d) 13

21. Who among the following is an educated male who hails from urban area?

- (a) 4 (b) 2
 (c) 11 (d) 5

22. Who among the following is uneducated and also an urban male?

- (a) 2 (b) 3
 (c) 11 (d) 12

23. Who among the following is only a civil servant but not a male nor urban oriented and uneducated?

- (a) 7 (b) 8
 (c) 9 (d) 14

24. Who among the following is a male, urban oriented and also a civil servant but not educated?
 (a) 13 (b) 12
 (c) 6 (d) 10

25. Who among the following is a male civil servant, who is neither educated nor belongs to urban area?
 (a) 7 (b) 13
 (c) 4 (d) 1

Direction (Question 26 to 35): In the following figure, the circle stands for employed, the square stands for hard working, the triangle stands for rural and the rectangle stands for intelligent. Study the figure carefully and answer the questions that follow.

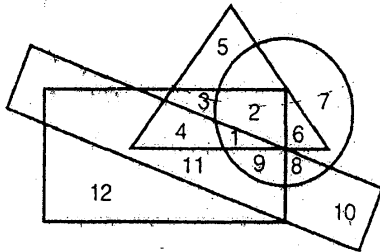

26. Non-rural, employed, hard working and intelligent people are indicated by region
 (a) 8 (b) 9
 (c) 10 (d) 11
 (d) 12
27. Non-rural, employed people who are neither intelligent nor hard working are represented by region
 (a) 12 (b) 11
 (c) 10 (d) 7
 (e) 5
28. Intelligent, employed and hard working non rural people are indicated by region
 (a) 11 (b) 6
 (c) 9 (d) 4
 (e) 3

29. Hard working non-rural people who are neither employed nor intelligent are shown in region
 (a) 8 (b) 7
 (c) 6 (d) 10
 (e) 12

30. Employed, hard working and intelligent rural people are indicated by region
 (a) 1 (b) 2
 (c) 3 (d) 4
 (e) 5

31. Rural hard working people who are neither employed nor intelligent are indicated by region
 (a) 6 (b) 5
 (c) 4 (d) 3
 (e) 2

32. Rural employed people who are neither intelligent nor hard working are indicated by region
 (a) 2 (b) 4
 (c) 6 (d) 9
 (e) 10

33. Rural people who are hard working and employed but not intelligent are indicated by region
 (a) 1 (b) 2
 (c) 3 (d) 4
 (e) 5

34. Unemployed rural hard working and intelligent people are indicated by region
 (a) 1 (b) 2
 (c) 3 (d) 4
 (e) 5

35. Rural employed people who are neither intelligent nor hard working are indicated by region
 (a) 10 (b) 9
 (c) 6 (d) 4
 (e) 2

□□□□

Solutions

1. (c) The required region is the one which is common to the triangle and the circle but is not a part of the square i.e. IV.
2. (b) The required region is the one common to all the three circles i.e. c.
3. (d) The required region is the one which is common to circles P and R but is not a part of circle Q i.e. b.
4. (a) The required region is the one which lies inside circle P but is not common to circle Q or circle R or both i.e. a
5. (b) The required region is the one which is common to circles P and Q but lies outside circle R i.e. d
6. (b) The required region is the region which is common to the triangle and square but lies outside the circle i.e., B.
7. (c) The required region is the one which is common to the circles 2, 3 and 4 but is not a part of circle 1 i.e. M.
8. (d) The required region is the one which is common to all the four circles i.e. E.
9. (c) The required region is the one which is common to the circles 1, 2 and 4, but lies outside circle 1 i.e., F.
10. (d) The required region is the one which does not lie inside circles 1, 2 and 4 i.e. L.
11. (b) The given conditions are satisfied by the persons denoted by the region which is common to circles 1 and 2 but is not a part of either circle 3 or circle 4 i.e. B.
12. (b) Strong army men will be represented by the region which is common to the square and the triangle but lies outside the circle i.e. 4
13. (d) The required region is the one common to the circle and triangle i.e. regions 5 and 6
14. (d) The required region is the one common to the triangle and circle but lies outside the square i.e. 6
15. (a) The required region is the one common to the triangle and square i.e. regions 5 and 7.
16. (b) The required region is the one common to the parallelogram, triangle and circle i.e. 3
17. (a) The required region is the one which is common to two circles X and Z but lies outside circles Y. i.e. T.
18. (d) The person satisfying the given conditions is represented by the region which is common to the triangle and the rectangle but lies outside the circle i.e. 11.
19. (b) The person satisfying the given conditions is represented by the region which lies inside the circle but outside the square, the rectangle and the triangle i.e. 3.
20. (c) The person satisfying the given conditions is represented by the region which lies outside the rectangle and is common to the circle and the square i.e. 10.
21. (a) The person satisfying the given conditions is represented by the region which is common to the triangle and the rectangle and also lies inside the circle i.e. 4
22. (d) The person satisfying the given conditions is represented by the region which lies outside the triangle and is common to the circle and the rectangle i.e. 12.
Remember: The condition which is not mentioned shouldn't be considered or assumed. For instance, here, 6 also denotes the required region. But since it lies inside the square and there is no mention of 'civil servant', so it cannot be the answer.
23. (a) The person satisfying the given is denoted by the region which lies inside the square but outside the circle, rectangle and triangle i.e. 7.

- 24.(c) The person satisfying the given conditions is denoted by the region which is common to the rectangle, circle and the square but lies outside the triangle i.e. 6.
- 25.(b) The person satisfying the given conditions is represented by the region common to the rectangle and the square but lying outside the triangle and the circle i.e. 13
- 26.(b) The rectangle set of people is represented by the region which lies outside the triangle and is common to the circle, square and rectangle i.e. 9.
- 27.(d) The required set of people is represented by the region which lies outside the triangle, inside the circle but outside the rectangle and the square i.e. 7
- 28.(c) The required set of people is represented by the region which is common to the rectangle, circle and square but lies outside the triangle i.e. 9.
- 29.(e) The required set of people is denoted by the region which lies inside the square but outside the triangle, circle and rectangle i.e. 12.
- 30.(a) The required set of people is denoted by the region common to the circle, square, rectangle and triangle i.e. 1
- 31.(d) The required set of people is represented by the region which is common to the triangle and the square but lies outside the circle and rectangle i.e. 3.
- 32.(c) The required set of people is denoted by the region which is common to the triangle and the circle, but is not a part of either the rectangle or the square i.e. 6.
- 33.(b) The required set of people is represented by the region which is common to the triangle, square and circle but is not a part of the rectangle i.e. 2.
- 34.(d) The required set of people is represented by the region which lies outside the circle and is common to the triangle, square and rectangle i.e. 4
- 35.(c) The required set of people is denoted by the region which is common to the triangle and circle but is not a part of either the rectangle or the square i.e. 6.

□□□□

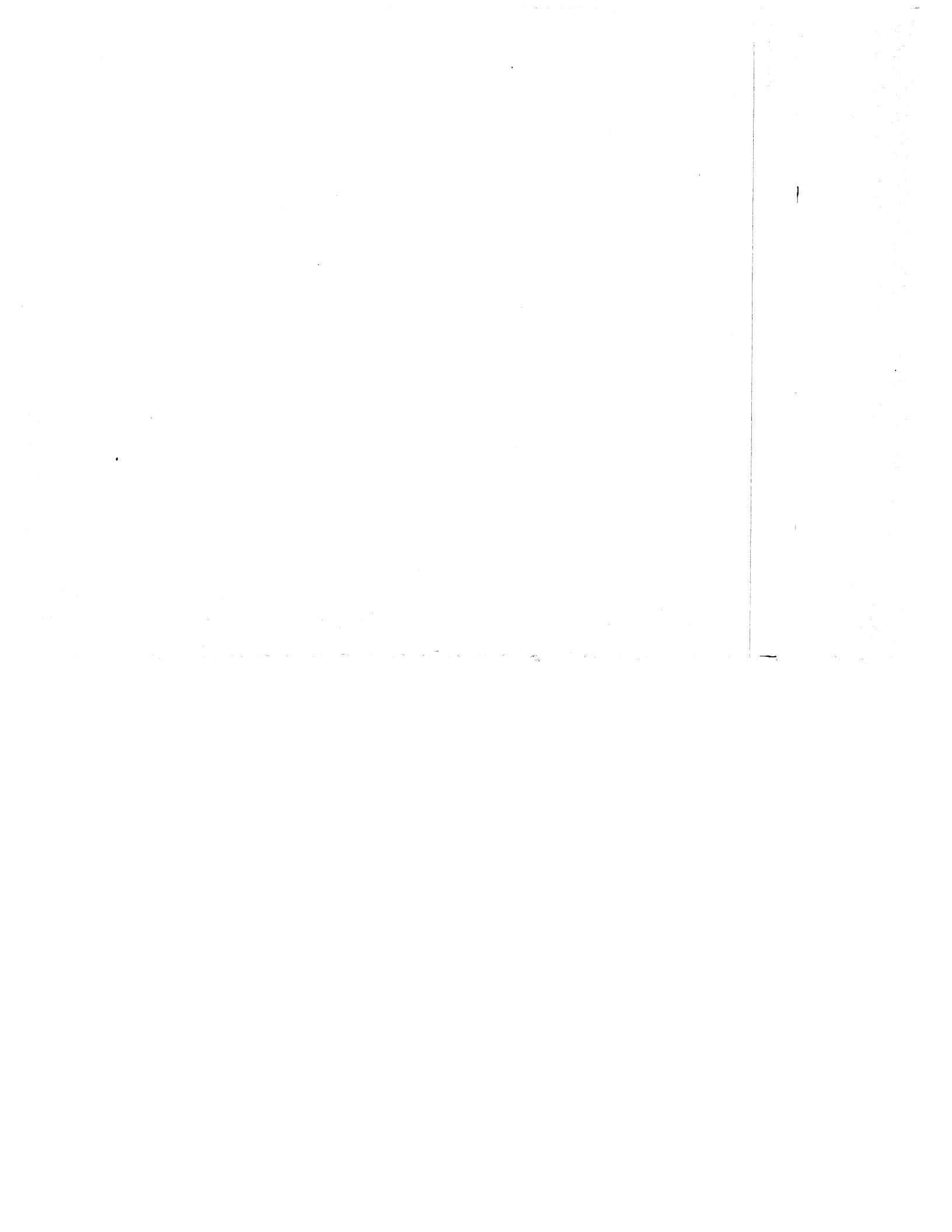



Analytical Reasoning



Practice Exercise: I

Direction for Questions: (1 to 3)

- (i) Six friends A, B, C, D, E and F are sitting along the sides of a hexagonal table for playing a game, though not necessarily in the same order.
- (ii) F, who is sitting exactly opposite of A, is to the immediate right B.
- (iii) D is between A and B and is exactly opposite to C.
1. A is sitting between which of the following pairs of persons?
(a) D and E (b) B and E
(c) E and C (d) none of these
 2. Who is sitting opposite B?
(a) E (b) F
(c) A (d) C
 3. Three of the following are alike in a certain way on the basis of sitting positions and so from a group. Which is the one that does not belong to the group?
(a) B, C (b) A, D
(c) B, F (d) E, A

Direction for Questions: (4 to 8)

- A, B, C and D are four friends living together in a flat and they have an agreement that whatever edible comes they will share equally among themselves. One day A's uncle came to him and gave a box of laddoos. Since no one was around, A divides the laddoos in four equal parts and ate his share after which he put the rest in the box. As he was closing the box, B walked in and took the box. He again divided in four equal parts. A and B ate one part each and kept the remaining laddoos in the box. Suddenly C appeared and snatched the box. He again divided the laddoos in four equal parts, the three of them ate one part each and kept the remaining laddoos in the box. Later when D came again divided the laddoos in four equal parts and all four ate their respective share. In total D ate 3 laddoos.
4. How many laddoos, in total did C eat?
(a) 12 (b) 15
(c) 39 (d) none of these
 5. How many laddoos, in total did B eat?
(a) 24 (b) 15
(c) 39 (d) none of these
 6. How many laddoos, in total did A eat?
(a) 56 (b) 68
(c) 71 (d) none of these

7. How many laddoos were given to A by his Uncle?

- (a) 128 (b) 125
(c) 113 (d) none of these

8. How many laddoos, did A eat the first time?

- (a) 32 (b) 24
(c) 15 (d) none of these

Direction for Questions: (9 to 13)

- (i) A, B, C, D, E, F, G and H are eight friends. Three of them play cricket and table tennis each and two of them play football. Each one of them has a different height
- (ii) The tallest does not play football and the shortest does not play cricket
- (iii) F is taller than A and D but shorter than H and B. E who does not play cricket, is taller than B and is second to the tallest. G is shorter than D but taller than A.
- (iv) H, who is fourth from the top, play table tennis with D.
- (v) G does not play either cricket or football. B does not play football.

9. Who is the tallest?

- (a) B (b) H
(c) C (d) Data inadequate

10. Who is the shortest?

- (a) G (b) D
(c) A (d) Data inadequate

11. Which of the following pairs of friends play foot ball?

- (a) EF (b) EA
(c) HF (d) Data inadequate

12. What is F's position from the top when they are arranged in descending order of their height?

- (a) Fifth (b) Fourth
(c) Sixth (d) none of these

13. Which of the following group of friends play cricket

- (a) CAE (b) CBF
(c) CBA (d) none of these

Direction for Questions: (14 to 17)

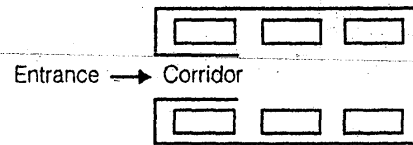

The plan above shows an office block for six officers—A, B, C, D, E and F. Both B and C occupy offices to the right of the corridor (as one enters the office block) and A occupies an office to the left of the corridor. E and F occupy offices on opposite sides of the corridor but their offices do not face each other. The offices of C and D face each other. E does not have a corner office. F's office is further down the corridor than A's, but on the same side.

14. If E sits in his office and faces the corridor, whose office is to his left?

- (a) A (b) B
(c) C (d) D

15. Whose office faces A's office?

- (a) A (b) C
(c) D (d) E

16. Who is/are F's neighbour(s)?

- (a) A only (b) A & B
(c) C (d) B & C

17. D was heard telling someone to go further down the corridor to the last office on the right. To whose room was he trying to direct that person?

- (a) A (b) B
(c) C (d) F

Direction for Questions: (18 to 22)

A, B, C, D, E, F and G are travelling in three different vehicles. There are at least two passengers in each vehicle—Maruti, Santro, Opel—and only one

of them is a male. There are two engineers, two doctors and three teachers among them.

- (i) C is lady doctor and she does not travel with the pair of sisters, A and F
- (ii) B, a male engineer, travels with only G, a teacher in Maruti
- (iii) D is a male doctor
- (iv) Two persons belonging to the same profession do not travel in the same vehicle.
- (v) A is not an engineer and travels in Santro.

18. What is F's profession?

- (a) Engineer (b) Doctor
- (c) Teacher (d) Data inadequate

19. In which vehicle does C travel?

- (a) Maruti (b) Santro
- (c) Opel (d) Data inadequate

20. Which of the following represents the three teachers?

- (a) GEF (b) GEA
- (c) GBF (d) Data inadequate

21. How many lady members are there among them?

- (a) Three (b) Four
- (c) Three of four (d) Data inadequate

22. Which of the following is not correct

- (a) E-Male-Teacher
- (b) B-Male-Engineer
- (c) A-Female-Teacher
- (d) All are correct

Direction for Questions: (23 to 27)

Six friends A, B, C, D, E and F work in different companies namely- Pentasoft, Quark, Raymond's Sunmet, Trump & Gates and Udupi, and each wears company-sponsored different coloured shirts, viz. Blue, Green, Pink, Yellow, Purple and Red though not necessarily in the same order.

- (i) The one wearing the Blue shirt works in Sunmet and the one wearing a Green shirt works in Pentasoft.

(ii) F does not work in Raymond's or Trump and Gates.

(iii) A wears Pink shirt and works in Quark

(iv) D does not work in Trump & Gates and Purple coloured shirt is not sponsored by Raymond's.

(v) E works in Udupi and neither D nor B works in Sunmet

(vi) Trump & Gates does not sponsor Purple or Yellow coloured shirts and C works in Pentasoft.

23. Which colour shirt is sponsored by Raymond's

- (a) Yellow
- (b) Blue
- (c) Pink
- (d) cannot be determined

24. Which pair is correctly matched?

- (a) Red-Raymond's-A
- (b) Red-Trump & Gates-B
- (c) Green-Raymond's-C
- (d) none of these

25. Which of the following is true?

- (a) Udupi sponsors Green Shirt
- (b) D is working in Trump & Gates
- (c) E wears Red Shirt
- (d) Red shirt is sponsored by Trump & Gates

26. What is the sequence of companies representing A, B, C, D, E & F?

- (a) Quark, Pentasoft, Trump & Gates, Raymond's Udupi, Sunmet
- (b) Quark, Trump & Gates, Pentasoft, Raymond's Udupi, Sunmet
- (c) Quark, Pentasoft, Trump & Gates, Sunmet, Udupi, Raymond's
- (d) none of these

27. If Raymond's and Sunmet decide to interchange the colours of sponsored shirts, then which two persons had to interchange their shirt?

- (a) D & F (b) A & C
- (c) D & E (d) B & D

Direction for Questions: (28 to 30)

Five courses – A, B, C, D and E each of one month duration are to be taught from January to May one after the other though not necessarily in the same order by lectures P, Q, R, S and T. P teaches course 'B' but not in the month of April or May. Q teaches course 'A' in the month of March. R teaches in the month of January but does not teach course 'C' or 'D'.

28. Which course is taught by S?

- (a) C (b) E
(c) Either C or D (d) D

29. Which lecture's course immediately follows after course B?

- (a) Q (b) P
(c) S (d) T

30. Which course is taught in the month of January?

- (a) C (b) D
(c) E (d) Data inadequate

Direction for Questions: (31 to 34)

Rajeev planted some plants in his lawn but in a certain fixed pattern:

- (i) In most of the rows there are neither Rose nor Marigold
(ii) There are two more row of Orchids than Tulips and two more rows of Rose than Orchids.
(iii) There are four more rows of Rose than Tulips.
(iv) There aren't as many rows of Lilly as Fireball.
(v) There is one less Marigold row than Rose
(vi) There is just one row of Tulips
(vii) The maximum number of rows he planted is six.

31. How many rows of rose the planted?

- (a) Two
(b) Five
(c) Four
(d) cannot be determined

32. Which of the above information is redundant and can be dispensed with?

- (a) (i) (b) (iii)
(c) (i) and (iii) both (d) All are necessary

33. What is the sum of the rows of Orchids and Marigold he planted?

- (a) Three
(b) Nine
(c) Seven
(d) Cannot be determined

34. How many rows of fireball did he plant

- (a) Two (b) Six
(c) Two or Six (d) Data inadequate

Direction for Questions: (35 to 37)

(i) Five friends, Amar, Kapil, Sarvesh, Rohan and Nagesh wear trousers of different colours– red, yellow, blue, white and green (not necessarily in the same order)

(ii) Each one of them has different likings, viz, reading, playing travelling, singing and writing.

(iii) Kapil, who has liking for singing does not wear yellow trousers. Sarvesh wears red trousers and does not like reading or writing. Nagesh likes to play and does not wear blue or Yellow trousers. Amar has liking for writing and Rohan does not wear yellow or green trousers.

35. What is the colour of Kapil trousers?

- (a) White (b) Blue
(c) Green (d) Data inadequate

36. What is the liking of Sarvesh?

- (a) Writing (b) Travelling
(c) Reading (d) Data inadequate

37. Which of the following combinations of person–colour–liking is correct?

- (a) Rohan–Blue–Reading
(b) Nagesh–White–Playing
(c) Amar–Yellow–Writing
(d) None of these



Solutions

Solution (1 to 3)

Constrict the following figure to solve the questions:

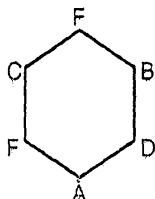

1. (a)
2. (a)
3. (a)

Solution (4 to 8)

Start from the last line. D ate 3 laddoos before D ate the laddoos there should be $3 \times 4 = 12$ laddoos. Before C ate the laddoos there should be $12 \times 3 + 12 = 48$ laddoos. Before B ate the laddoos, there should be $24 \times 2 + 48 = 96$ laddoos.

Before A ate laddos, these should be $\frac{96 \times 4}{3} = 128$ laddoos

At the Beginning 128 laddoos

	A	B	C	D	Remaining
A's share	32				96
B's share	24	24			48
C's share	12	12	12		12
D's share	3	3	3	3	0
	71	39	15	3	

4. (b)
5. (c)
6. (c)
7. (a)
8. (a)

Solution 9 to 13

From statement (iii) and (iv) we get the order of height as : Tallest

- C —|— ↓
- E —|—
- B —|—
- H —|—
- F —|—
- D —|—
- G —|—
- A —|—

Shortest

- C Does not play football and A does not play cricket. (From ii)
- E Does not play football and A does not play cricket. (From ii)
- E does not play cricket (from iii)
- H and D play table-tennis
- G does not play either cricket or football so he play table tennis
- B does not play either football and there are only 3 table tennis players so B plays cricket similarly C plays cricket and A & E play football.
- The remaining person F will play cricket

9. (c)
10. (c)
11. (b)
12. (a)
13. (b)

Solution (14 to 17)

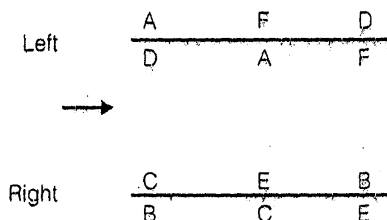

From the last sentence, we get that F is also on the left side, So E will be on the right side. D will be on the left side

E does not have a corner office so he must be in the middle. E and F do not face each other and F's office is further down the corridor, So F occupies the last office on the

left side. Office of C and D face each other, so C will have first office on the right side and D will have the first office on the left side.

14. (c)

15. (d)

16. (a)

17. (b)

Solution (18 to 22)

The following table will emerge out of the given clues :

Vehicle	Person	Profession
Maruti	B (+)	Engineer
	G (-)	Teacher
Santro	A -	Teacher
	F -	Engineer
Opel	D +	Doctor
	C -	Doctor
	E +	Teacher

Since C and D are doctor and A is not an engineer, hence A is a teacher

Since A travels in a Santro, C will travel in an Opel. Also, A and F will be together. Given A and F are pairs of sisters, both are females.

In Maruti, only two pair B & G travel, So G is a female. The two persons belonging to the same profession do not travel in the same vehicle, So D travel in a santro-There are two doctors, two engineers and three teachers and the person of same profession do not travel in the same vehicle, So F is an engineer. And E is a male teacher.

18. (a)

19. (c)

20. (b)

21. (b)

22. (d)

Solution (23 to 27)

23. (a)

24. (b)

25. (d)

26. (b)

27. (a)

Solution (28 to 30)

The following picture will emerge out of the given clues :

Jan	—	E	—	R
Feb	—	B	—	P
March	—	A	—	Q
April	—	C/D	—	S/T
May	—	D/C	—	T/S

28. (c)

29. (a)

30. (c)

Solution (31 to 34)

$$\rightarrow O = T + 2$$

$$R = O + 2$$

Also

$$R = M + 1$$

When $T = 1, O = 3, R = 5, M = 4$

Since from (iv)

$$\text{Lily} < \text{Fireball}$$

So, $\text{Lily} = 2, \text{Fireball} = 6$

31. (b)

32. (c)

33. (c)

34. (b)

Solution (35 to 37)

Following picture will emerge out of given clues

Amar	—	Yellow	—	Writing
Kapil	—	(not yellow)	—	Singing
Sarvesh	—	Red	—	Travelling
Rohan	—	(not yellow/ green)	—	Reading
Nagesh	—	(not blue/ yellow)	—	Playing

35. (d)

36. (b)

37. (c)

